

EWT 9275

Quality, Design and Innovation



MONOLITH

LIEBHERR

The Monolith stands for a new generation of fully integrated refrigerators, freezers, and wine cabinets. Based on over 60 years of innovation and German engineering, it sets new standards for food and wine storage. With its impressive dimensions, clean lines, and modern cooling and freezing components, the Monolith was designed to inspire awe and integrate seamlessly into your home and kitchen.

Luxury wine cabinet features include our adjustable InfinityLight LED system which casts beautiful even side lighting, and a soft, brightening effect upon opening the doors plus the intuitive InfinitySwipe 3.5-inch touch & swipe screen. Other unique features include the InfinityBoard, InfinityProtection and an activated charcoal filter to preserve and protect fine wines.

Pair the Monolith wine cabinet with any refrigerator and freezer available in this premium series. Stainless steel or aluminium handles and a stainless steel front are available as optional accessories.

Possible Side-by-Side combinations

- EGN 9171 & EKB 9471 & EWT 9275
- EGN 9171 & EKB 9671 & EWT 9275
- EGN 9271 & EKB 9471 & EWT 9275
- EGN 9271 & EKB 9671 & EWT 9275



Monolith 61.0 cm

EWT 9275

- Infinity Swipe
- Infinity Light
- Wine
- Soft System
- Telescopic Rails

Sound rating dB(A) *
Usable capacity in litres
Max. No. of Bordeaux bottles (0.75 litre)
Energy consumption in 365 days/24 h°
Number of storage shelves
Running on telescopic rails
InfinityBoard
Shelf material
Electronic control
Temperature range °C
Temperature zones
Temperature alarm
Interior lighting
Door alarm
Safety thermostat
FreshAir activated charcoal filter
Door type
Door hinge
Product Dimensions
in cm (H/W/D)
Cut Out Dimensions
in cm (H/W/D)
Gross / Net weight in kg
Voltage V / Connected load in A / Frequency Hz
Warranty

42
320
100
155
9
9
Yes
Aluminium & beech
InfinitySwipe
+5°C to +20°C
3
Visual and audible
InfinityLight
Audible
Yes
Yes
Yes
Insulated glass door
Right, reversible*
212.6 / 60.2 / 61
213.4 / 61 / min. 63.5
174 / 162
220-240 / 1.5 / 50
5 Years

* Noise output - according to EN 60704-3.

*** Please contact your Liebherr Authorised Dealer for door reversal.

° Measurements taken at +25°C ambient and +12°C interior temperature tested by Liebherr Germany (not to Australian standards).

SoftSystem: Monolith's SoftSystem technology allows the appliance doors to close gently and effortlessly, protecting wine bottles from vibration caused by slamming and bringing a bit of relaxation into every glass poured.



Soft System

InfinityProtection: The Monolith wine cabinet utilises two temperature sensors in each of the three compartments to maintain precise temperatures and protect wines from high temperature fluctuations – a feature unique to Liebherr.



Activated Charcoal Filter: Monolith's FreshAir activated charcoal filter features one charcoal filter in each compartment to preserve and protect your fine wines. Incoming air is purified while damaging odours are filtered out to prevent contamination.



Telescopic Rails

Telescopic Rails: Monolith's flexible shelves on telescopic rails allow for custom configurations to hold larger wine and champagne bottles. With this feature, you can fit all the bottles in your treasured collection and get the most out of the wine cabinet.

InfinityBoard: A unique design of the Monolith wine cabinet, the InfinityBoard can be pulled out to hold bottles while organising your wine collection. Serve guests with ease while keeping bottles right where they belong.

Customised Labelling: Located on each wine shelf trim, our customised labelling feature allows you to organise and easily identify your collection, making sure each wine bottle is exactly where you want it to be.

Accessories

Stainless steel front

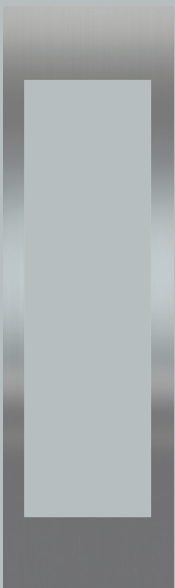

61.0

Stainless steel front 61.0 cm (Part no. 39901533)

Handle variants



Flat brushed aluminium handle (Part no. 39901461)



Round stainless steel handle (Part no. 39901489)



Square brushed aluminium handle (Part no. 39901492)

Stainless steel toe kick



Base - trim / 61.0 cm (Part no. 39901496) Stainless steel toe kicks are available in different lengths to suit installation with other Monolith appliances.

Other accessories

Side-by-side kit (Part no. 39901428) A SBS kit is required when there is a spacing of less than 102 mm between appliances. Includes a side wall heater to prevent condensation, metal brackets with screws, and a finishing strip (approx. 6-8 mm) to fill the gap between the appliances.

Door hinge exchange set (Part no. 39902399) To be used when reversing factory-fitted hinges. Door reversal must be performed by a Liebherr authorised dealer.

Charcoal filter (Part no. 39881116) Recommended to be changed every 12 months.

Product Dimensions

61.0 cm appliance

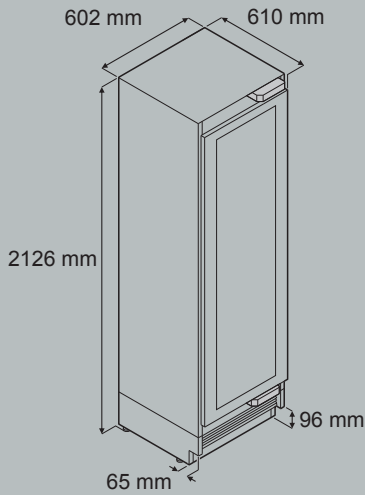

IMPORTANT!
Stated minimum height dimensions include height of the adjustable feet when fully inserted.

Height can be increased by a maximum of 19 mm by turning the adjustable feet. When the appliance is fitted in the recess, the appliance must be raised by turning the adjustable feet so that the appliance top has contact with the anti-tipping bracket. This results in a 4" (102 mm) toe kick height.

Internal door panel	External door panel
A = 273 mm	A = 279 mm
B = 12.5 mm	B = 12.5 mm
C = 658 mm	C = 670 mm

Dimension A = without mounted door handle

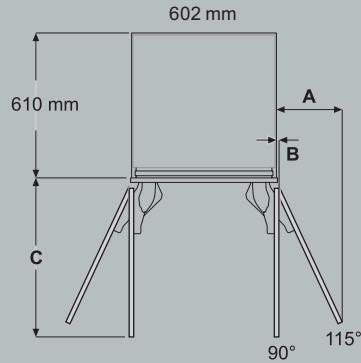

Cut Out Dimensions

Continuous toe kick

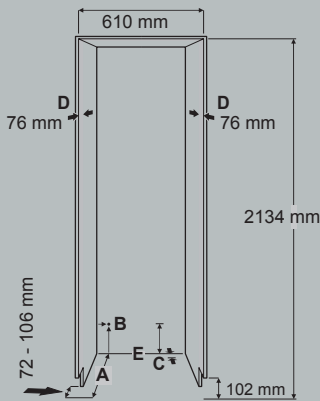

Individual toe kick

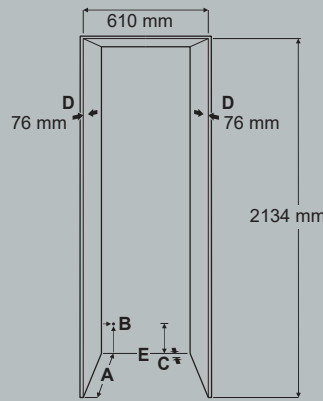

A: Unit depth with external door panel installation: 635 mm.
 Unit depth with internal door panel installation: 635 mm + thickness of custom panel.

B: Point at which the mains cable exits from the rear of the appliance (19 mm from the left and 127 mm from the floor). The free length of the mains cable is 2.5 m.

C: The appliance has a recess in this area for cable and water line routing: Depth is 25 mm and height is 140 mm across the entire appliance width.

D: This surface is visible when the appliance door is opened. Designed finish is therefore recommended.

E: The anti-tipping device which is positioned at the base of the appliance must be secured to the floor or to the wall.

Door Front Dimensions

and dimensions of free length for power

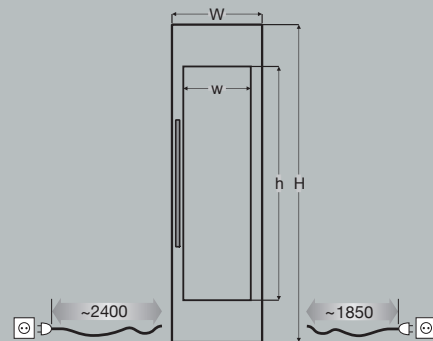

Integrated installation
 H = 2029 mm / h = 1495 mm
 W = 603 mm / w = 432 mm

Frameless installation
 H = 2032 mm (plus the dimensions of overlapping of the panel on the top)
 W = 610 mm (plus the dimensions of overlapping of the panel on both sides)

Front thickness = min. 16 mm / max. 30 mm
 Front and handle weight = max. 24 kg

Installations behind the appliance are not possible.

* If a five-piece shaker style front is used, which is thinner than the minimum front thickness, shorter screws than those supplied in the accessory pack must be used.

Note: Whilst every effort is made to ensure all specifications and information in this flyer are accurate, Liebherr reserves the right to make changes without notification. Where actual appliance measurements, specifications, and ratings are crucial, we recommend that the actual appliance installation instructions that accompany each appliance be checked. Liebherr will not be liable for any loss.