

---

# Uncompromising Freshness, Unrivalled Luxury

---

Discover our freestanding and  
fully-integrated appliances.

# LIEBHERR

Refrigeration and freezing





# Contents

---

Liebherr Group	4
Quality	6
Freshness technology	8
BioFresh Professional with HydroBreeze	10
BioFresh Professional with Fish & Seafood safe	12
Convenience and flexibility	14
Product responsibility	16
Freestanding appliances	18
Series	20
Unique features	21
Fully integrated appliances	42
Series	44
Unique features	46
Wine cabinets	70
Unique features	72
Liebherr Barrique	84
Unique features	86
Specifications	96

# Global success: The Liebherr Group

Liebherr is a third-generation, family-owned company founded in 1949 by Hans Liebherr with his ground-breaking invention of the world's first mobile tower crane.

With over 70 years of success, Liebherr is known as a pioneer in high-quality, breakthrough innovations and countless cutting-edge technologies in numerous industries. One of the world's largest manufacturers of construction machinery, Liebherr has expanded its broadly diversified portfolio to 13 product segments including earthmoving, deep foundation machines, mobile and crawler cranes, tower cranes, concrete technology, material handling technology, mining, maritime cranes, aerospace and transportation systems, gear technology and automation systems, components, hotel, and refrigeration and freezing. The company currently employs about 48,000 people in more than 140 companies in over 50 countries worldwide.



Mobile cranes



Aerospace



Earthmoving



Crawler cranes



Refrigeration and freezing



Liebherr-Hausgeräte GmbH, Germany

**Liebherr-Hausgeräte –  
specialists in refrigeration and freezing**

Liebherr-Hausgeräte covers the full range of refrigeration and freezing for domestic and commercial use. Headquartered in Germany, Liebherr-Hausgeräte has an impressive range of more than 3,000 products in its portfolio.

## Even the smallest detail deserves the utmost attention.

---

We prioritise uncompromising quality – down to the tiniest screw. And we have done so from the very start. We have been manufacturing high-quality refrigerators and freezers and selling them worldwide since 1954. However, at heart we are still a family business with deep roots in Germany. It is here that we continue to develop all our products just as before. German engineering – out of loyalty to our founder and with the knowledge built up by generations of engineers.

### Built to last

You can experience our quality standards in the smallest of details. For example, before a door hinge is approved by us, it must pass through at least 100,000 opening cycles. This corresponds to a usage period of more than 15 years. We also test all other functional parts to ensure that they can last just as long.

And if, contrary to expectations, a small detail no longer meets your requirements, you or our premium service partners can usually correct it quickly. Because all our appliances are extremely repair-friendly. We keep all essential spare parts in stock for well over 10 years. This practice is not just sustainable, it also saves you money on minor repairs or the purchase of a new appliance.



EasyFresh for fruit and vegetables from the Pure series upwards.





SBSbs 8673



Magnetic door gasket ensures safe closing.  
\*subject to model

### **We don't just say it. We also guarantee it.**

During manufacturing we inspect all components of our refrigerators with great care and test them far more rigorously than required by law – and we do this for the last time just before they are packaged. It is only then that our appliances can relax a little. All of our manufacturing sites are certified in accordance with the international standards for quality ISO 9001, energy management ISO 50001 and environmental management ISO 14001. Therefore, nothing could be easier for us than to guarantee for at least two years that our products are free of material and manufacturing faults and are particularly easy to install.

In short: one thing is certain – you will be able to enjoy your Liebherr for a long time.

## Uncompromising freshness

---

You don't compromise when you're shopping. You look for natural ingredients, the best quality and maximum freshness. Of course, anyone who values good food wants to keep it fresh for as long as possible. That is precisely why we have developed innovative freshness technologies and improve them year after year, so your food still tastes fresh after some time in the refrigerator.





**EasyFresh – ideal for fruit and vegetables**

Unpackaged fruit and vegetables feel right at home here. Stored at the same temperature as the fridge compartment and sealed airtight in the safe, lettuce, for example, is still crisp and fresh after 7 days.



**BioFresh – our all-rounder**

The reliable BioFresh technology stores groceries at a temperature just above 0 °C, much cooler than in the rest of the appliance. With the perfect humidity, fruit and vegetables stay fresh even longer in the airtight Fruit & Vegetable safe. Meat, fish and dairy products can enjoy ideal conditions in the Meat & Dairy safe.



**BioFresh Professional with HydroBreeze**

A cold mist that covers fruit and vegetables like a protective balm. It ensures crisp freshness and improves structure – the special wow effect for fruit and vegetables in the BioFresh Professional safe.



**BioFresh Professional with Fish & Seafood safe.**

Particularly delicate foods like fish and seafood are best stored in icy temperatures and at low humidity. The constant temperature of -2 °C in the Fish & Seafood safe is therefore ideal to keep these items tasting fresh for longer.



**DuoCooling – no drying out**

The two completely separate refrigeration circuits ensure that there is no air exchange between the fridge and freezer compartments. Groceries do not dry out nor spread odour.



**NoFrost – no more defrosting**

The automatic defrosting function guarantees that frozen foods remain fresh. There is no longer a need to store frozen food temporarily during manual defrosting. The constant optimal freezing remains the same without interruptions.

## Cool and misty. Perfect weather for your vegetables.

Our HydroBreeze feature exemplifies our highest standard of freshness. A cold mist covers fruit and vegetables like a protective balm in the BioFresh Professional safe. The mist ensures crisp freshness, improves structure and keeps produce with fine leaves fresh for longer. It also creates an optical wow effect in the BioFresh Professional safe.



### Nature's freshness secret

The Salinas valley in California is known as the salad bowl of the USA. And that is because of the particularly favourable climatic conditions. Its proximity to the cool waters of the Pacific means a fine, moist mist covers the valley and its fields in summer. This prevents the crops growing here from drying out. It is precisely this idea which inspired our BioFresh Professional with HydroBreeze.



Every time the door is opened, a fresh, cold mist is generated.

Hydro  
Breeze

+8 days

+10 days

+8 days

+12 days

+40 days

+11 days

+12 days

Specifications made in days are comparisons to the normal fridge compartment.

# Relish the freshness of the sea.

To keep fish and seafood tasting as fresh as at the market stall, even after a few days, you need a fridge compartment which maintains their freshness; such as our Fish & Seafood safe. Fish and seafood can be stored here at  $-2\text{ }^{\circ}\text{C}$  and low humidity. Perfect conditions to enjoy that freshly caught flavour for much longer.



Specifications made in days are comparisons to the normal fridge compartment.



**Flexible use**

The surface of the BioFresh Professional safe can be adjusted to individual requirements. The  $-2\text{ }^{\circ}\text{C}$  can be partially or even completely adjusted to a temperature zone at just above  $0\text{ }^{\circ}\text{C}$ . This is the optimal storage environment for meat and dairy products. We have illustrated these four options below:



## Convenience and flexibility



### Drawers on telescopic rails

Pleasantly easy opening and closing – even when fully loaded – ensures that all of the groceries are perfectly accessible.



### FlexSystem

Ensures clear order in the BioFresh safe. It is perfect for storing smaller portions of fruit and vegetables or sensitive groceries.



### VarioSafe

Allows you to arrange smaller items clearly in the interior – at whatever height you prefer.



# Thinking beyond just today

We are fastidious in adopting a holistic approach to sustainability when designing our appliances. The key elements of this are the durability of our appliances, maximum energy efficiency and reducing food waste. Why do we do all this? Because a holistic approach is needed to protect both people and the environment in equal measure.

## Reducing food waste

Everyone who stores food in the optimum climate plays a big part in reducing unnecessary food waste. Our appliances make this possible – with a combination of innovative features:

First: Our freshness technologies. DuoCooling in our fridge-freezers, for example, prevents your groceries from drying out faster than need be. Innovative freshness technologies such as BioFresh ensure perfect storage conditions that significantly extend product life and freshness. So there's no need to throw food away before its time, and you don't need to go shopping so often. And the largest zero-degree compartments on the market provide enough space for extra-large amounts of groceries.

Second: Our SmartDevice app also helps you to store your food properly, giving your food a longer shelf life so you can enjoy it for even longer.

Third: Our appliances are intelligent and let you know if perfect storage for your groceries is at risk. For example, by using a door alarm to tell you if the appliance door is still open.





# Perfectly thought out: a powerful, complete package

Our fridges are real all-rounders. Along with their low power consumption, they also have impressively low noise levels, plenty of space for groceries, a long service life and reliable power reserves for when it really matters. We take account of a great many factors during the development stage and can offer a perfectly balanced appliance. Or to put it another way: all good things come in fours.



## Energy consumption

Our refrigerators and freezers occupy top positions in the efficiency rankings. In this way, they protect the precious resources of our environment and – thanks to low electricity costs – your wallet too.



## Cooling volume

We have the perfect appliance for all family sizes, lifestyles and niche heights. We make sure that we do not waste a single litre of capacity in the extra-large drawers – right down to the smallest detail, for example with the lighting solutions that have been integrated in the housing to save space.



## Noise level

The boundaries between the kitchen and living areas are becoming ever more blurred in modern households. This underlines the importance of particularly quiet appliances. Our range of refrigerators and freezers therefore offers a wide selection of extremely quiet appliances. In some cases, it even reaches the ultra-quiet noise level of 32 db.



## Cooling performance

Intelligent sensor technology constantly adapts the cooling performance to current use, making our refrigerators and freezers very energy-efficient and economical in everyday use. At the same time they also have plenty of power in reserve, for example to cool down a large quantity of groceries after the weekly shop.

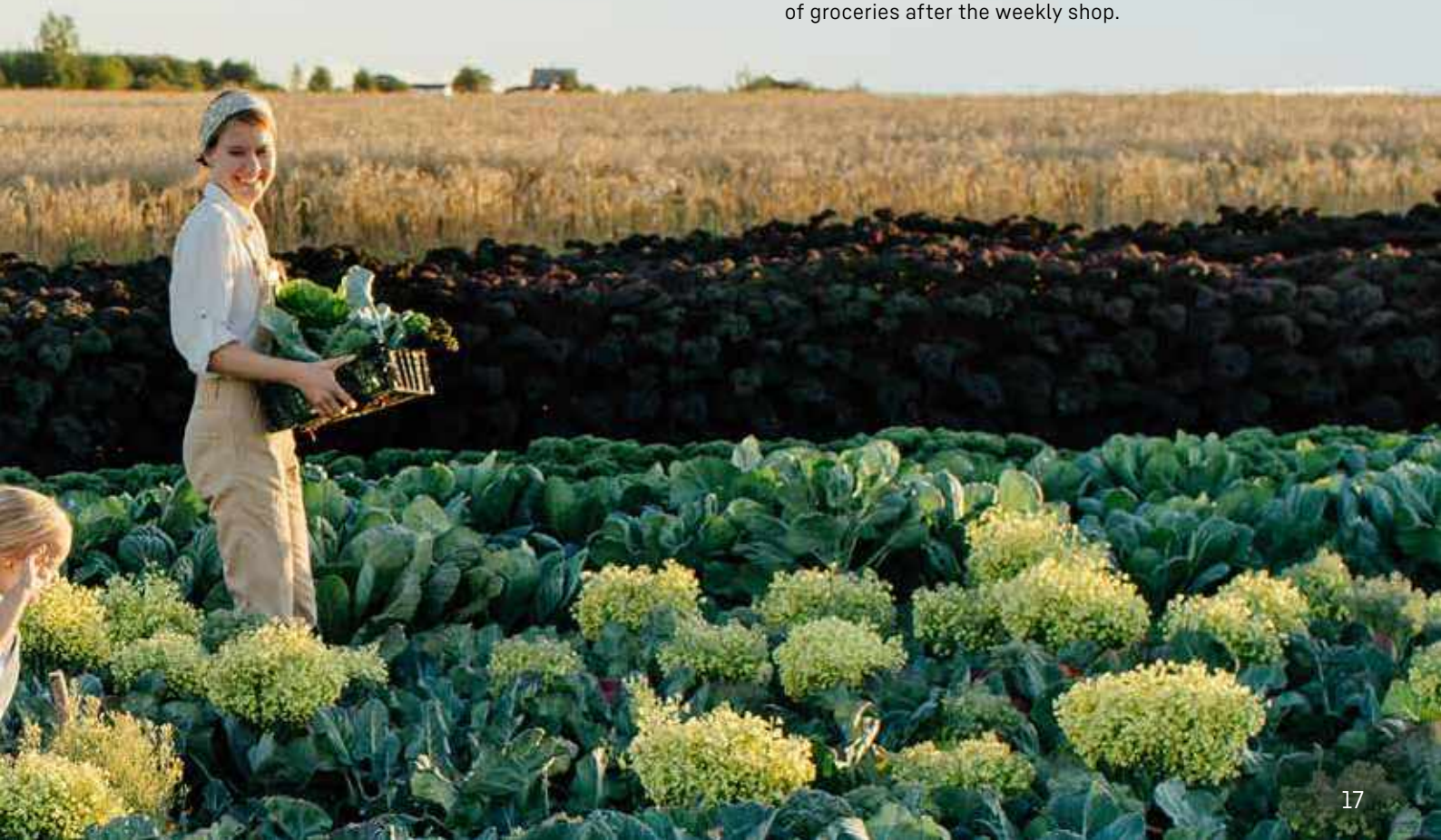

# Freestanding appliances







BioFresh 0°C



fresh-Safe

Bio  
Fresh

BioFresh-Safe

# Unique features.

---



## IceMaker

Are there any ice cubes left? An IceMaker means you never have to ask. With the IceMaker with fixed water connection, the water comes directly from the tap. The MaxIce function allows you to produce up to 1.5 kg of ice cubes a day. The ice cube separator helps to divide the drawer into any size you want – for example, ice cubes on the left, ice cream on the right – or just for ice cubes.



## SoftSystem

From breakfast to a midnight snack – a fridge needs to be open and closed on many occasions. And your Liebherr makes this a lot of fun. With the SoftSystem, your fridge door closes softly and safely, and in a way which is pleasantly quiet and light. Bottles stored in the inside door remain securely in place – nothing rattles or wobbles.



## BioFresh

BioFresh provides the perfect climate for long-lasting food storage. When stored at just over 0°C and at the ideal humidity level, fruit, vegetables, meat and fish all retain their nutritious vitamins for longer.



## SmartSteel

A specially treated stainless steel finish that significantly reduces the visibility of fingerprints, making it very easy to clean. Maintain this beautiful surface simply by wiping it with a soft, damp cloth.



## Touch-Display

The elegant MagicEye control system with the innovative, user-friendly Touch-electronic feature ensures that the temperature in the fridge compartment and freezer compartment is kept to the selected temperature. All the functions can be simply and conveniently operated at the touch of a finger.



## PowerCooling system

Do you want to be sure that the cold is distributed as evenly as possible in your refrigerator? If so, the PowerCooling system is what you need. The fan – as powerful as it is quiet – distributes the cold air efficiently throughout the entire refrigeration compartment.



**Bio  
Fresh  
Plus**

**No  
Frost**

**Ice  
Maker**

**Wine**

**Soft  
System**

**Soft-  
Telescopic**

**Smart  
Steel**

SBSes 8486

# Masterpiece in Innovative Freshness Technology.

---

Timelessly elegant with a full stainless steel body, our award-winning BluPerformance SBSes 8486 Side-by-Side Fridge-Freezer with six different climate zones boasts an array of innovative solutions.

The dual-zone wine compartment allows you to store two different types of wine at their respective desired temperatures, ranging from +5°C to +20°C. The NoFrost freezer with automatic IceMaker provides professional freezing technology for long-term freshness while a spacious refrigerator provides an extended shelf life for fresh groceries.

The BioFresh-Plus compartment includes a versatile Fish & Seafood safe and offers an adjustable temperature range of 0°C and -2°C to provide even more storage flexibility for a wide array of meat and produce.

Technical data see page 96.





Bio  
Fresh  
Plus

No  
Frost

Ice  
Maker

Soft  
System

Soft-  
Telescopic

Smart  
Steel

SBSes 8484



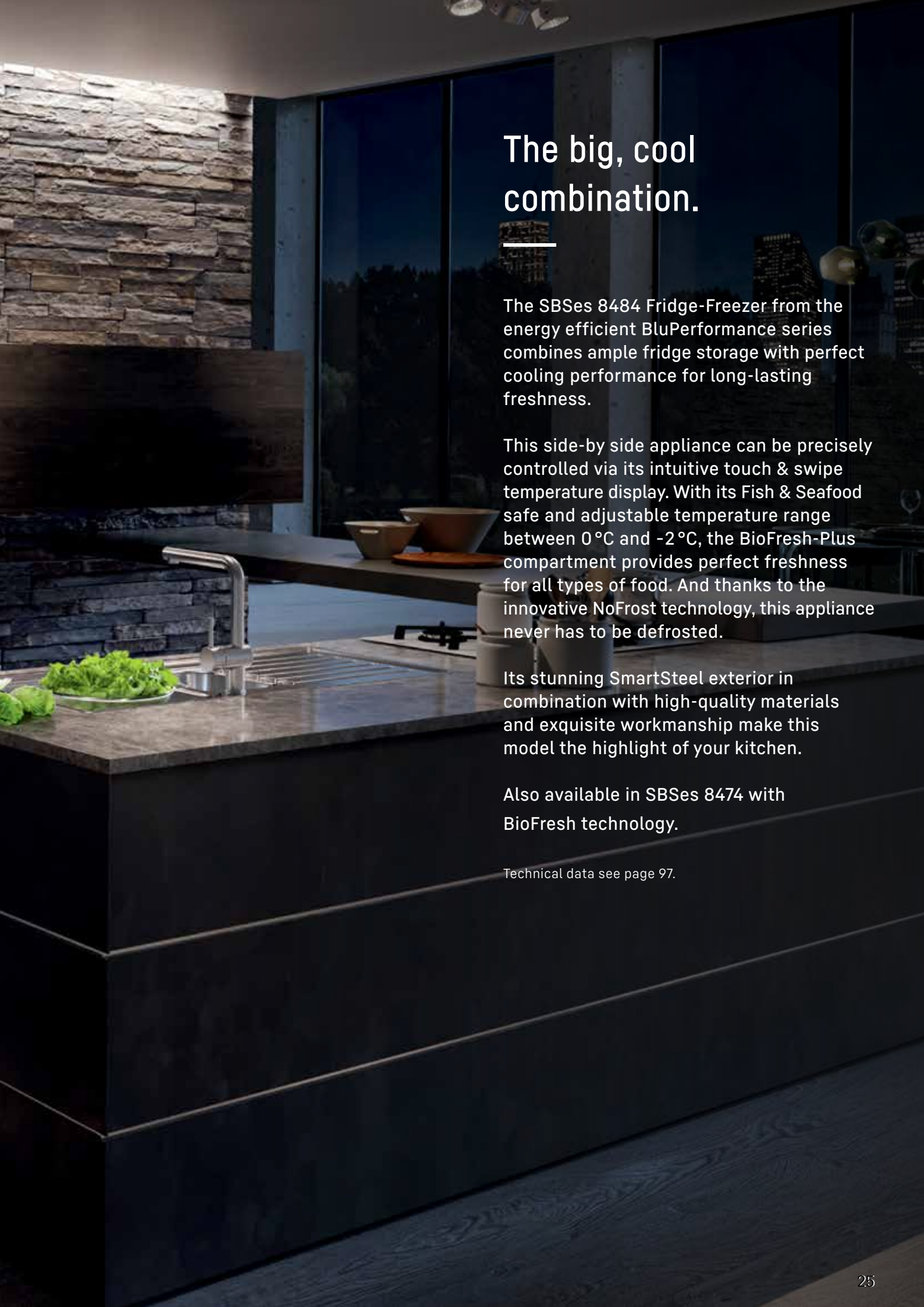

## The big, cool combination.

---

The SBSes 8484 Fridge-Freezer from the energy efficient BluPerformance series combines ample fridge storage with perfect cooling performance for long-lasting freshness.

This side-by-side appliance can be precisely controlled via its intuitive touch & swipe temperature display. With its Fish & Seafood safe and adjustable temperature range between 0 °C and -2 °C, the BioFresh-Plus compartment provides perfect freshness for all types of food. And thanks to the innovative NoFrost technology, this appliance never has to be defrosted.

Its stunning SmartSteel exterior in combination with high-quality materials and exquisite workmanship make this model the highlight of your kitchen.

Also available in SBSes 8474 with BioFresh technology.

Technical data see page 97.



Bio  
Fresh

No  
Frost

Ice  
Maker

Soft  
System

Soft-  
Telescopic

Smart  
Steel

SBSes 8474

## Freshness for healthy living.

---

An all-round carefree package for your food: the SBSes 8474 freestanding Side-by-Side fridge-freezer. From our BluPerformance range, this appliance combines perfect cooling performance for long-lasting freshness, ample storage space, and a classic design.

All its five BioFresh drawers run on telescopic rails and provide optimal storage conditions for your groceries at a temperature of just above 0°C in combination with ideal humidity. Our IceMaker has a fixed water connection and provides ice cubes for every occasion. The SuperCool and SuperFrost functions allow food to be cooled or frozen quickly. And if you need extra storage space, VarioSpace makes it possible.

Also available in SBSes 8484 with BioFresh-Plus technology.

Technical data see page 98.



Bio  
Fresh  
Plus

No  
Frost

Ice  
Maker

Soft  
System

Soft-  
Telescopic

Smart  
Steel

SBSes 8683

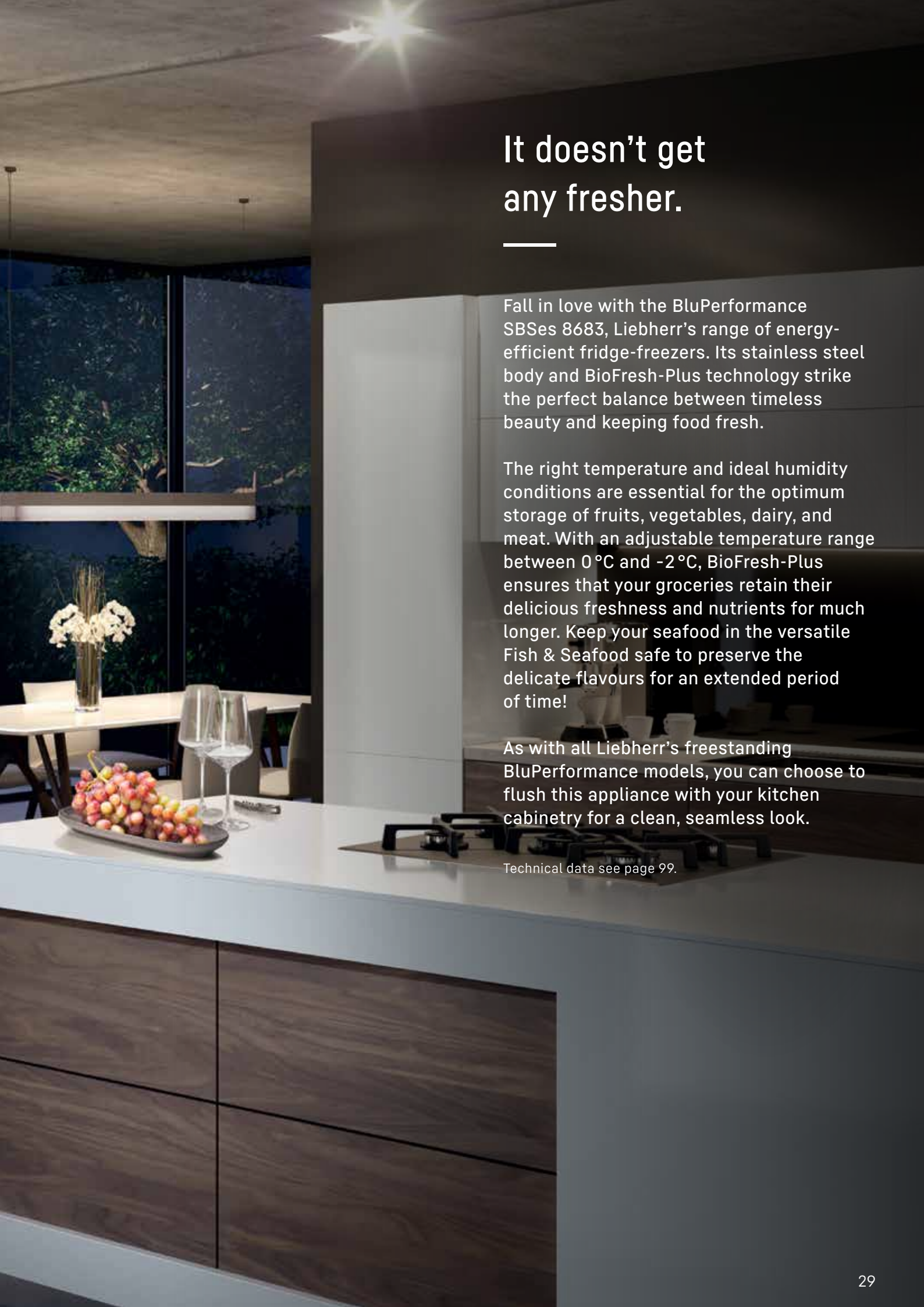

## It doesn't get any fresher.

---

Fall in love with the BluPerformance SBSes 8683, Liebherr's range of energy-efficient fridge-freezers. Its stainless steel body and BioFresh-Plus technology strike the perfect balance between timeless beauty and keeping food fresh.

The right temperature and ideal humidity conditions are essential for the optimum storage of fruits, vegetables, dairy, and meat. With an adjustable temperature range between 0 °C and -2 °C, BioFresh-Plus ensures that your groceries retain their delicious freshness and nutrients for much longer. Keep your seafood in the versatile Fish & Seafood safe to preserve the delicate flavours for an extended period of time!

As with all Liebherr's freestanding BluPerformance models, you can choose to flush this appliance with your kitchen cabinetry for a clean, seamless look.

Technical data see page 99.



**Bio  
Fresh**

**No  
Frost**

**Ice  
Maker**

**Soft  
System**

**Soft-  
Telescopic**

**Smart  
Steel**

SBSbs 8673

## An optical highlight in BlackSteel.

---

Elevate your living space with the SBSbs 8673 BlackSteel masterpiece. The black transverse-polished finish lends a premium appeal and exceptional textural depth to the fridge-freezer to give this striking model a luxurious, exclusive appearance.

Get your daily dose of freshness with Liebherr's patented BioFresh technology which allows each drawer to be adjusted individually to provide the ideal humidity for different types of food. Our IceMaker ensures that you stay refreshed in the heat.

This energy-efficient BluPerformance model is also available in stainless steel as SBSes 8673.

Technical data see page 100.





SBSes 8673



# Freshness with style and elegance.

---

Volume, efficiency, economy, ease of use, and outstanding design are the key features of the SBSes 8673 side-by-side fridge-freezer from Liebherr's BluPerformance series. High-quality components and materials, and perfect workmanship combined with precise touch electronics system are what made this appliance so efficient.

BioFresh technology allows your fruits, vegetables, meat, fish, and dairy products to stay fresher for longer. Meanwhile NoFrost technology ensures that this appliance never has to be defrosted. And thanks to its premium SmartSteel surface, this timelessly elegant model is easy to clean and will be a visual highlight in your home!

This energy-efficient BluPerformance model is also available in BlackSteel as SBSbs 8673.

Technical data see page 101.

Bio  
Fresh

No  
Frost

Ice  
Maker

Soft  
System

Soft-  
Telescopic

Smart  
Steel



No  
Frost

Smart  
Steel

SBSef 7242



## A spacious refrigerator and freezer all in one.

---

The SBSef 7242 Side-by-Side Fridge-Freezer brings together high-quality components and meticulous workmanship to guarantee food freshness and user-friendliness.

The freezer offers up to eight drawers to give an extra-large capacity for freezing your food. The transparent fruit and vegetable drawers in the refrigerator provide a clear view of the stored food and slide out effortlessly on the roller system.

The stainless doors with special SmartSteel coating makes this appliance easier to clean.

Technical data see page 102.



CNPef 4516

## Practicality and elegance for your kitchen

The CNPef 4516 Bottom-mount Freezer is the practical and elegant solution for small footprint installations such as studio apartments.

Thanks to VarioSpace, the drawers and safety glass shelves can be removed to conveniently create extra storage space for larger frozen goods.

Independent temperature control of the fridge and freezer compartments is facilitated by DuoCooling, two separately adjustable cooling circuits to prevent air exchange between the two compartments. This eliminates odour transfers and prevents food from drying out.

For larger households, double your food storage capacity by installing two units together.

Technical data see page 103.

No  
Frost

Duo  
Cooling

Smart  
Steel

Vario  
Space



CNPef 4416

## Smart design for smaller footprints.

---

The compact fridge-freezer combination CNPef 4416 is the perfect choice for smaller footprint installations like galley kitchens or apartment living. It includes smart interior design features like a beverage rack, foldable glass shelf, and a stainless back wall which prevents ice build-up and dripping.

The SmartSteel door is scratch resistant and makes fingerprints virtually disappear – one wipe of a cloth is all it takes to keep the surface clean. The CNPef 4416 can be paired with itself with the help of our optional side by side kit for even more fridge and freezer space.

Technical data see page 103.

No  
Frost

Duo  
Cooling

Smart  
Steel

Vario  
Space



Smart  
Steel

Duo  
Cooling

No  
Frost

Bio  
Cool

CNef 4315





## Energy efficiency at its best.

---

The CNeF 4315 Bottom-mount Freezer is the perfect solution for galley kitchens or small families. The most compact model from Liebherr's BluPerformance range, it ensures maximum energy efficiency while providing more space for your food.

Its BioCool drawer allows you to regulate its humidity level within so that fresh fruits and vegetables can be stored up to twice as long. The door exterior is coated with SmartSteel, a specially treated stainless steel surface that significantly reduces the visibility of fingerprints, making it very easy to clean so that your fridge always looks good as new.

Technical data see page 104.

# Fully integrated appliances





For a clear overview.  
Even before you  
open the fridge.

○ Pure

◇ Plus

△ Peak

○ Pure series

The Pure series is our basic class. Simple, clear and perfectly equipped for all essential needs. The Pure series has been reduced to the essentials. But full to the brim with the highest level of Liebherr quality.

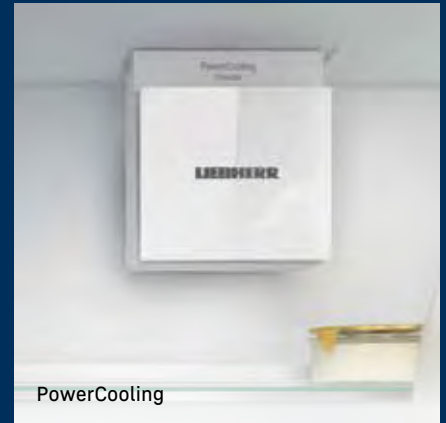

◇ Plus series

The Plus series builds on our Pure series and has many impressive additional details. Above all, plus means a plus in comfort. The appliances not only provide first-class refrigerating and freezing, they are also just that little bit smarter. They help make much of the handling a little easier.

△ Peak series

The Peak series sits at the top of our series. Here the best is combined with the best. There is no compromise. Innovative Liebherr technology meets high-end design and comfort solutions that are simply first in its class. Appliances in this series are for those who want everything.





BioFresh Professional 0°C



Bio  
Fresh  
Professional

BioFresh 0°C



# Unique features



## PowerCooling

Do you want to be sure that the cold is distributed as evenly as possible in your refrigerator? If so, the PowerCooling system is what you need. The fan – as powerful as it is quiet – distributes the cold air efficiently throughout the entire refrigeration compartment.



## LightTower

Enjoy an optimally illuminated interior: the LightTower shows off the food in its best light and is positioned so that all of your filled fridge is illuminated at all times. The flush mounting of the LightTower in the side walls means there is also more space for your food.



## Touch & Swipe Display

Control of your Liebherr at your fingertips: thanks to the Touch & Swipe display, you can operate your refrigerator intuitively and with ease. Simply select functions such as SuperCool on the colour display by tapping and swiping. The temperature is controlled just as easily. And, what if you are not actively using the display? Well, it then shows you the actual temperature.



## Fish & Seafood safe

BioFresh Professional offers even more flexibility for the individual storage of food. The adjustable temperature range of 0 °C and -2 °C keeps fish and seafood fresh for significantly longer than in a conventional refrigeration compartment. The BioFresh Professional safe includes a versatile Fish & Seafood safe.



## IceMaker

Are there any ice cubes left? An IceMaker means you never have to ask. With the IceMaker with fixed water connection, the water comes directly from the tap. The MaxIce function allows you to produce up to 1.5 kg of ice cubes a day. The ice cube separator helps to divide the drawer into any size you want – for example, ice cubes on the left, ice cream on the right – or just for ice cubes.



## SuperSilent

Shhh – listen carefully. Your Liebherr is so quiet that you have to strain your ears to hear it. How is this achieved? All refrigeration components such as compressors, valves, fans and evaporators are optimised and perfectly adapted to one another. This means you only hear what you want to hear in your kitchen.



SIFNh 5188 Δ Peak series | EWTdf 3553 | IRBh 5170 Δ Peak series



# The ultimate indulgence

In the IRBh 5170 refrigerator, cold mist from HydroBreeze covers fruit and vegetable like a protective balm in the BioFresh Professional safe. Adjust the temperature down to  $-2\text{ }^{\circ}\text{C}$  to create a low humidity environment for retaining the freshness of your catch of the day in the Fish & Seafood safe.

For parties and gatherings, IceTower in the SIFNh 5188 freezer produces up to 1.2 kg of ice cubes daily whereas VarioSpace provides added flexibility for large cakes.

The insulated triple glazed door of our EWTdf 3553 dual-zone wine cellar protects your finest collection from UV exposure. Handcrafted beechwood shelves on telescopic rails reduces vibrations, allowing wines to develop in peace.

Technical data see page 106/107/118.

**Bio  
Fresh  
Professional**

**Hydro  
Breeze**

**Fish &  
Seafood**

**No  
Frost**

**Super  
Frost**

**Super  
Cool**

**Vario  
Space**

**Wine**

**2  
Zones**

**Humidity  
Select**

**Fresh  
Air**

**Steel  
Interior**

**Presentation  
Shelf**

**Soft  
System**

**LED**

**Telescopic  
Rails**

**Soft-  
Telescopic  
Rails**

**Touch &  
Swipe-  
Display**

**Glass &  
Steel  
Interior**

**Light  
Tower**

**Ice  
Tower**

**Smart  
Device  
ready**

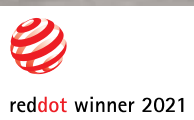

IRBPh 5170 Δ Peak series

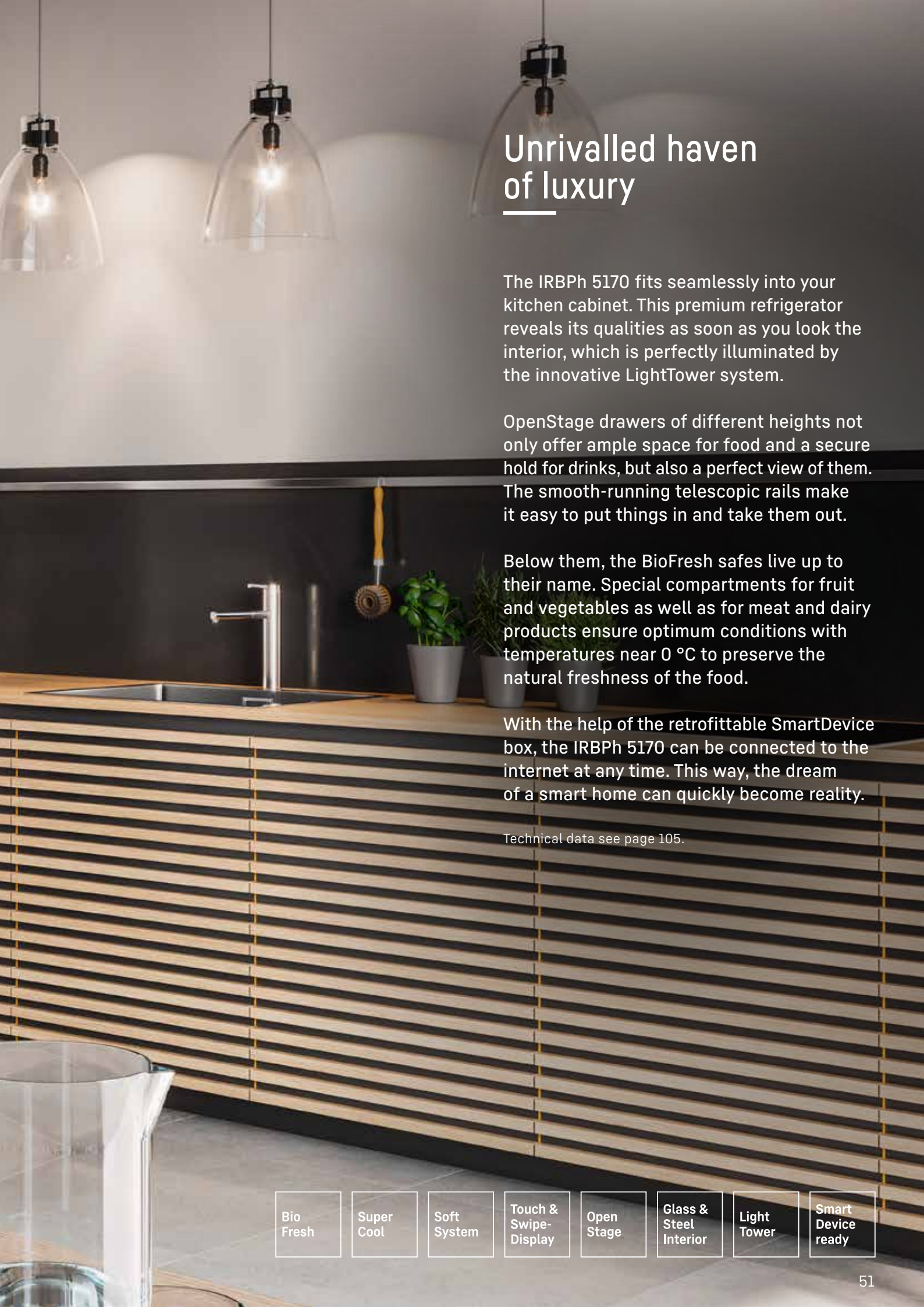

## Unrivalled haven of luxury

The IRBPh 5170 fits seamlessly into your kitchen cabinet. This premium refrigerator reveals its qualities as soon as you look the interior, which is perfectly illuminated by the innovative LightTower system.

OpenStage drawers of different heights not only offer ample space for food and a secure hold for drinks, but also a perfect view of them. The smooth-running telescopic rails make it easy to put things in and take them out.

Below them, the BioFresh safes live up to their name. Special compartments for fruit and vegetables as well as for meat and dairy products ensure optimum conditions with temperatures near 0 °C to preserve the natural freshness of the food.

With the help of the retrofittable SmartDevice box, the IRBPh 5170 can be connected to the internet at any time. This way, the dream of a smart home can quickly become reality.

Technical data see page 105.

Bio  
Fresh

Super  
Cool

Soft  
System

Touch &  
Swipe-  
Display

Open  
Stage

Glass &  
Steel  
Interior

Light  
Tower

Smart  
Device  
ready



SIFNh 5128 ◊ Plus series | IRBh 5120 ◊ Plus series



## Savour the freshness within.

If two appliances were ever made for each other, it's the SIFNh 5128 and the IRBh 5120, and both fully integrated, extremely spacious and at the cutting edge of refrigeration technology.

With features such as the intuitive touch display or the SoftSystem for particularly soft-closing doors, the side-by-side fridge-freezer combination offers every imaginable convenience. And with to the retrofittable SmartDevice box, you're ready to enjoy the comforts of a smart home.

In the refrigerator, BioFresh safes with temperatures just above 0 °C ensure extra freshness for unpackaged vegetables or meat. In the freezer, the innovative NoFrost technology spares you the chore of defrosting. You'll never need to do it again.

Technical data see page 108.

Bio Fresh	No Frost	Super Frost	Super Cool
Soft System	Touch-Display	Vario Space	Smart Device ready



ICNh 5173 Δ Peak series | ICBNh 5173 Δ Peak series

# See food in a new light.

Our most premium range of new Fully Integrated appliances: Meet the ICNh 5173 and ICBNh 5173.

One highlight exclusive to the ICBNh 5173 is the brand new HydroBreeze which produces a fresh, cold mist that coats fruits and vegetables to ensure their crisp freshness. Temperature in the BioFresh Professional Fish & Seafood safe can be set to  $-2^{\circ}\text{C}$ , allowing you to retain the delicate taste of freshly bought seafood for longer periods.

The ICNh 5173 Fridge-Freezer with EasyFresh safes offers plenty of space for your favourite food and ingredients.

Both models in this combination are equipped with an IceMaker and a high-resolution Touch & Swipe display. Their exquisite interior craftsmanship of glass and stainless steel illuminated by our new LightTower makes every peek inside a visual experience.

Technical data see page 109.

Bio  
Fresh  
Professional

Easy  
Fresh

Duo  
Cooling

No  
Frost

Super  
Silent

Soft  
System

Glass &  
Steel  
Interior

Light  
Tower

LED

Ice  
Maker

Touch &  
Swipe-  
Display

# Built-in luxury

ICNh 5123 and ICNh 5133: models from our new Fully Integrated selection.

This side-by-side fridge-freezer combination offers plenty of storage space with EasyFresh safes that allow different humidity modes for a wide array of fresh groceries. NoFrost technology ensures a permanently frost-free freezer compartment.

Thanks to Liebherr's door-on-door technology, our fully integrated appliances fit perfectly into spacious kitchens and integrate seamlessly into your existing cabinetry.

Being SuperSilent models due to the special design and low-noise components, this combination is extremely quiet. Thanks to our SoftSystem the appliance doors always close gently even when fully loaded.

Technical data see page 110.

Easy  
Fresh

Duo  
Cooling

No  
Frost

Super  
Silent

Soft  
System

LED

Ice  
Maker  
Water tank





ICNh 5123 ◇ Plus series | ICNh 5133 ◇ Plus series

# Wonderfully fresh, always

The sophisticated ICNh 5103 fits seamlessly into your kitchen: Elegant, slim, full of innovative features.

In the EasyFresh safe, you can store fresh fruits and vegetables in the best possible way. With its airtight seal, no moisture can escape and groceries stays as fresh and appetising as at the market stand.

Thanks to DuoCooling technology, this built-in fridge-freezer has two completely separate cooling circuits. This prevents any air exchange between the refrigerator and freezer compartments, keeping your food from drying out and eliminating odour transfers. Want to keep your homemade pizza or cake fresh? The ICNh 5103 even has room for a whole baking tray!

Technical data see page 111.

Easy  
Fresh

Duo  
Cooling

No  
Frost

Super  
Silent

Soft  
System

LED

Ice  
Maker  
Water tank





ECBN 6256

# Fresh on the inside, sleek on the outside

Behold the ECBN 6256 Fridge-Freezer with its magnificent French doors. Highlighted by BioFresh technology to provide targeted humidity for specific foods, this is your answer to style and freshness.

Our innovative DuoCooling system eliminates any odour transfers between the fridge and freezer compartments, while the plumb-in IceMaker provides an ample supply of perfect ice cubes.

Opt for our stainless steel panels and handles for that extra touch of elegance!

Technical data see page 112.

Bio  
Fresh

No  
Frost

Duo  
Cooling

Ice  
Maker

Soft  
System

# The spacious freshness centre

Seamlessly integrated with your custom kitchen cabinetry via the door-on-door system, the 91 cm wide built-in ECBN 6156 Fridge-Freezer is a real eye-catcher.

The generous fridge space and adjacently arranged BioFresh safes coupled with two NoFrost freezer drawers on telescopic rails offer optimum storage for all types of food. The plumbed-in IceMaker automatically keeps you topped up with the finest quality ice cubes so that you are prepared for every occasion.

Opt for our stainless steel panels and handles for that extra touch of elegance!

Technical data see page 112.

Bio  
Fresh

No  
Frost

Duo  
Cooling

Ice  
Maker





ECBN 5066



## More space for fresh ideas

At 76 cm wide, the built-in ECBN 5066 Fridge-Freezer is a slimmer version of the ECBN 6156 model. Features a special satin-finish on the LED light cover to create an appealing and sophisticated interior ambience.

Two BioFresh safes allows you to organise different types of foods through targeted humidity. The DrySafe is perfect for meat, fish, and dairy products while the HydroSafe keeps fresh fruits and vegetables crisp and fresh for longer. Our plumbed-in IceMaker automatically keeps you topped up with ice to keep you cool in the heat.

Opt for our stainless steel panels and handles for that extra touch of elegance!

Technical data see page 113.

Bio  
Fresh

No  
Frost

Duo  
Cooling

Ice  
Maker

# The smooth operator

A unique pull-out model, the SUIKo 1550 Undercounter Fridge serves as a great option for kitchen islands.

Mounted on soft telescopic rails to enhance user-friendliness and convenience, it comes with a practical bottle shelf and removable fruit and vegetable drawer. The large drawer can also be divided into two equal-sized compartments, with further storage space underneath.

SuperCool function quickly reduces temperature which is perfect for rapidly cooling down freshly stored food. The innovative LED light and special satin finish of the light cover produces a pleasant lighting atmosphere.

Technical data see page 114.



SUIKo 1550

# Convenience at your fingertips

Our space-saving undercounter appliances are the practical choice for compact living spaces. The SUIK 1510 Undercounter Fridge is great for fresh produce with height-adjustable glass shelves to ensure maximise storage flexibility.

The perfect companion for this undercounter fridge is the SUIG 1514 Undercounter Freezer with SmartFrost technology, allowing food to freeze faster and reducing ice build-up to make defrosting simpler and quicker.

Both models are equipped with innovative SoftSystem technology which ensures that the appliance door closes gently and automatically from an opening angle of approximately 30°. No ventilation grill is needed in your worktop as airflow enters and exits from the front of both undercounter models.

Technical data see page 115.



Soft  
System

Smart  
Frost





---

# Wine cabinets

---





On/Off



Ventilation



Light

5  
8  
16

Zone



Up



Down



Alarm





# Unique features



## LED lighting

The LED lighting in the individual wine compartments can be dimmed to give a pleasing ambient light inside the appliance. All Vinidor appliances are equipped with this innovative, no-heat LED lighting concept. The LED lighting can also be adjusted to operate continuously or in conjunction with door openings.



## Insulated glass door

Liebherr wine cabinets come with insulated glass doors with special UV protection. The double-glazed construction means that most of the damaging UV radiation is reflected away. In addition, LED lighting guarantees perfect illumination of the wine cabinet interior without risk of UV exposure.



## FreshAir activated charcoal filter

Environmental odours can have an wine stored for longer periods. Fresh air is supplied to Liebherr wine cabinets through the easily replaceable FreshAir activated charcoalfilter to ensure optimal air quality.



## Handcrafted beechwood shelves

Our natural, handcrafted, and untreated beechwood shelves release no chemical aromas into the environment that could adversely influence the flavour of wine. In addition, wooden shelves contribute to the reduction of vibrations which allows wine to develop in peace.



## Touch electronic control system

Our touch electronic control system is easy to navigate and enables tailored storage options. Temperature can be set between +5 °C and +20 °C based on your preference. In our multi-temperature models, each wine safe can be controlled independently, allowing different types of wine to be stored in one wine cabinet.



## Compressor

Specially developed compressors installed in the wine cabinets from Liebherr ensure that the wines are stored in a particularly low vibration environment.



WTes 5872

## Created for true wine connoisseurs

The WTes 5872 Multi-temperature Wine Cabinet satisfies your thirst for the smartest, most elegant ways to store wine. It adds sophisticated flair to entertainment areas while providing ideal conditions for wine to mature successfully. With three adjustable temperature zones, you can simultaneously store red wine, white wine, and champagne all at their optimum serving temperature between +5 °C and +20 °C.

An insulated glass door protects wines from damaging UV radiation while the presentation shelves allow the perfect display of your finest collection. Specially developed compressors provide a low vibration environment and telescopic rails help shelves to slide out gently without causing sudden movements that could damage your wine. An activated charcoal filter provides a permanent supply of odourless, fresh air.

Impress your guests with what is a true wine storage unit. Also available in two temperature zones as WTes 5972.

Technical data see page 116.

Wine

2  
Zones

Humidity  
Select

Fresh  
Air

Soft  
System

Telescopic  
Rails

Presentation  
Shelf

LED



LEIBERHARDT *Compass*

WKT 6451

# Quality wines deserve quality storage.

The WKt 6451 Wine Cabinet offers similar conditions to an underground wine cellar. Its solid door means that chances of condensation are reduced, making it easier to maintain in a tropical climate.

The handcrafted, untreated beechwood shelves release no chemical aromas into the environment that could adversely influence the flavour of wine. In addition, wooden shelves contribute to the reduction of vibrations which allows wine to develop in peace.

With the capacity to hold up to 312 Bordeaux bottles (0.75 litres), this jumbo model is one of the largest wine cabinets in the market – the perfect choice for serious wine collectors with a huge range of wine bottles to mature.

Technical data see page 117.

Wine

1  
Zone

Humidity  
Select

Fresh  
Air

Telescopic  
Rails

LED



reddot award 2018  
winner

EWTgb 3583

# Integrated solution for all your favourites.

The advanced dual-zone EWTgb 3583 offers several innovative solutions for wine storage. Controls are integrated into the insulation layer between the temperature zones, making it possible to set two different temperatures within the unit. Store red and white wines according to your preference – use the entire cabinet for one or store both, each at its optimum drinking temperature.

Environmental odours can affect wines stored for longer periods. In the wine cabinets, perfect air quality is ensured through an easily replaceable FreshAir activated charcoal filter.

For integration into handleless kitchen furniture, the handleless, full-surface insulated glass door with innovative TipOpen technology is the perfect solution. The glass door opens a few centimetres when tapped. If the door is not opened further after 3 seconds, the SoftSystem closes it again.

Technical data see page 118.

Wine

2  
Zones

Humidity  
Select

Fresh  
Air

Soft  
System

Telescopic  
Rails

Presentation  
Shelf

LED



EWTdf 3553



# Savour the difference with a Liebherr.

Like a shaken bottle of champagne, the EWTdf 3553 dual-zone wine cellar is absolutely exploding and overflowing with innovative features.

Its touch display controls are integrated into the insulation layer between the temperature zones, allowing you to set two different temperatures within the unit and simultaneously store red and white wines, each at its optimum drinking temperature. An insulated glass door protects your favourite collection from UV exposure while handcrafted beechwood shelves on telescopic rails reduces vibrations, allowing wines to develop in peace.

Seamlessly fit this built-in model into your customised kitchen décor or turn it into a stainless steel masterpiece with our selection of accessories.

Technical data see page 118.

Wine

2  
Zones

Humidity  
Select

Fresh  
Air

Soft  
System

Telescopic  
Rails

Presentation  
Shelf

LED



UWTes 1672 | UWKes 1752

- |      |                 |           |                  |     |
|------|-----------------|-----------|------------------|-----|
| Wine | Humidity Select | Fresh Air | Telescopic Rails | LED |
|------|-----------------|-----------|------------------|-----|

## A cabinet full of treasures

The UWKes 1752 Undercounter Wine Cabinet is ideal for storing wines for extended periods, allowing them to mature to perfection. Its LED lighting ensures uniform illumination of the interior without any damages caused by UV light.

If you like reds, whites, as well as champagne, pair the UWKes 1752 with our dual-temperature zone model UWTeS 1672. Now enjoy your favourite bottles all stored at their desired temperatures between +5 °C to +20 °C!

Technical data see page 119.





# Liebherr Barrique





# Unique features



## LED lighting

The tinted glass door provides not only a perfect UV protection, but also an optimum glance at wine. The integrated LED lighting ensures a pleasant illumination of the complete interior.



## Precision electronics

The precise electronic control system is equipped with a digital temperature display. The door and temperature alarm alerts of any irregularities, e.g. when the door is left open. The integrated lock on the front panel prevents unwanted access to the stored bottles.



## Handcrafted beechwood shelves

Our natural, handcrafted, and untreated beechwood shelves release no chemical aromas into the environment that could adversely influence the flavour of wine. In addition, wooden shelves contribute to the reduction of vibrations which allows wine to develop in peace.



## Presentation shelf

The presentation shelf, equipped with wooden angles, is ideal for presenting wine and storing open bottles safely. Up to 6 bottles can be set upright on the flexible shelf. In addition further bottles can be stored lying down either behind or at the side.



## Optimum humidity

Liebherr wine cabinets guarantee an optimum humidity and this ensured the corks are supple in place whilst still allowing the wine to breathe in its maturing process.



## Activated charcoal filter

The easy replaceable active charcoal filter purifies the incoming air to obtain an optimum odour-free interior.



LIEBHERR WKb 4612

WKb 4612



## Perfect display for all your favourites

With the capacity to hold 195 Bordeaux bottles, the spacious Liebherr Barrique WKb 4612 Wine Cabinet is ideal for the long-term storage and maturation of wines.

Constant temperature can be set as desired between +5 °C to +20 °C via the intuitive control system with digital temperature display.

Thanks to its coated glass door, wines will always be well-protected from UV radiation. Efficient LED lighting ensures that the interior is illuminated evenly and pleasantly, allowing you to proudly showcase your prized collection.

Also available in a shorter height as WKb 4112 with the capacity to store 168 Bordeaux bottles.

Technical data see page 120.

Wine

1  
Zone

Humidity  
Select

Fresh  
Air

Telescopic  
Rails

Presentation  
Shelf

LED

# Wine storage sophistication for your home

The WKb 4611 Wine Cabinet mimics the conditions of an underground wine cellar where its solid door creates a dark, undisturbed environment with zero exposure to UV light and heat fluctuations – perfect for maturing wines.

When humidity level falls below 50%, natural corks begin to shrink, causing oxygen to enter the bottle and damage stored wines. With a humidity range between 50% – 80%, Liebherr wine cabinets guarantee the ideal conditions to preserve the suppleness of wine corks which in turn prevents oxidation.

Your wines are always stored safely on our untreated beech wood shelves while an activated charcoal filter provides optimal air quality.

Technical data see page 120.



Wine

1  
Zone

Humidity  
Select

Fresh  
Air



WKb 4611



WKgb 4113

## The storage choice for wine aficionados

The Liebherr Barrique WKgb 4113 Wine Cabinet features an insulated full-glass, black door that provides protection from UV radiation and preserves the quality of wine.

Temperature can be adjusted between +5 °C to +20 °C and is ideal for the long-term storage of fine wines – be it for maturing or storage. Our integrated activated carbon filter absorbs odours from the ambient air and prevents the taste of fine wines from being impaired.

With its elegantly designed recessed handle, this wine cabinet looks perfect in any home or restaurant.

Technical data see page 121.

Wine

1  
Zone

Humidity  
Select

Fresh  
Air

LED

# Superb conditions for fine wines

Our most compact model from the Liebherr Barrique series, the WKb 1712 Wine Cabinet can store up to 60 Bordeaux bottles. Wines are stored optimally on three untreated, height-adjustable beech wood shelves.

Wines are well protected from UV radiation thanks to a tinted insulated glass door while the activated charcoal filter provides optimum air quality and is easy to replace.

Energy-efficient LED lighting ensures even and pleasant illumination so that your favourite bottles are seen in the best light.

Technical data see page 123.



Wine	1 Zone	Humidity Select	Fresh Air	LED
------	--------	-----------------	-----------	-----



WKb 1712

## Freestanding



### SBSes 8486 PremiumPlus



Energy consumption (kWh/yr)   Star rating	211   5.0 (left) 194   4.0 (right)
Max. No. of Bordeaux bottles (0.75l) *	48
Refrigerator capacity litre	366
BioFresh comp. litre	132
Wine comp. litre	153
Freezer capacity litre	126
Number of shelves (including divisible shelf) / Number of door racks & bins	10 / 5
Number of BioFresh drawers	3 with LED lighting
Number of freezer drawers	5 with LED lighting
Electronic control	2.4" TFT-colour temp. display, touch electronic
Door / side walls	stainless steel with SmartSteel / stainless steel with SmartSteel
Refrigerator temperature range °C	+2 °C to +9 °C
Freezer temperature range °C	-14 °C to -26 °C
Wine temperature range °C	+5 °C to +20 °C
Temperature alarm / Defrost type	visual and acoustic / automatic
Interior light	LED ceiling lighting with dimmer function
Door alarm	visual and acoustic
IceMaker	fixed water connection 3/4"
Ice cube output kg/24h	1.2
SoftSystem	yes
Door hinges	left / right
Product dimensions (H/W/D) cm	185 / 121 / 66.5
Net weight kg / Voltage V/Hz	159 / 220 - 240 / 50



### Installation Diagram (mm)

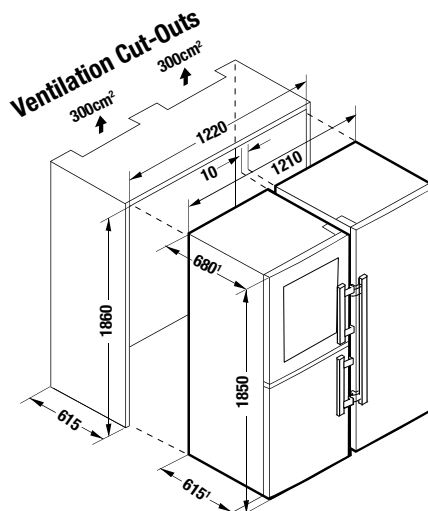
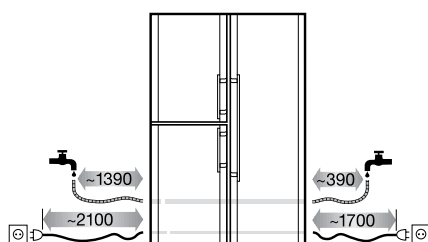





**SBSes 8484**  
PremiumPlus



Energy consumption (kWh/yr)   Star rating	204   5.5 (left) 194   4.0 (right)
Refrigerator capacity litre	538
BioFresh comp. litre	304
Freezer capacity litre	126
Number of shelves (including divisible shelf)	8
Number of door racks & bins	5
Number of freezer drawers	5 with LED lighting
Number of BioFresh drawers	5 with LED lighting
Electronic control	2.4" TFT-colour temp. display, touch electronic
Door / side walls	stainless steel with SmartSteel / stainless steel with SmartSteel
Refrigerator temperature range °C	+2 °C to +9 °C
Freezer temperature range °C	-14 °C to -26 °C
Temperature alarm	visual and acoustic
Defrost type	automatic
Interior light	LED ceiling lighting with dimmer function
Door alarm	visual and acoustic
IceMaker	fixed water connection 3/4"
Ice cube output kg/24h	1.2
SoftSystem	yes
Door hinges	left / right
Product dimensions (H/W/D) cm	185 / 121 / 66.5
Net weight kg	163.6
Voltage V/Hz	220 - 240/50



Installation Diagram (mm)

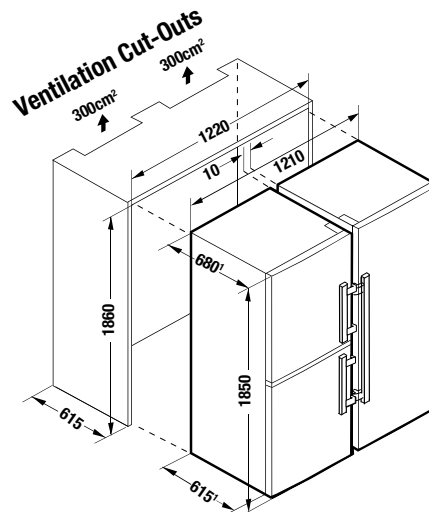
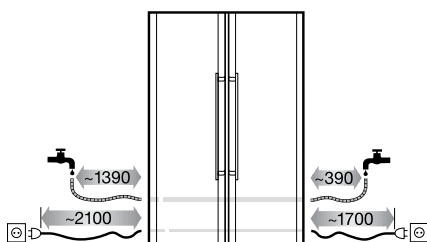

## Freestanding



### SBSes 8474 Premium



Energy consumption (kWh/yr)   Star rating	204   5.5 (left) 194   4.0 (right)
Refrigerator capacity litre	539
BioFresh comp. litre	305
Freezer capacity litre	126
Number of shelves (including divisible shelf)	8
Number of door racks & bins	5
Number of freezer drawers	5 with LED lighting
Number of BioFresh drawers	5 with LED lighting
Electronic control	2.4" TFT-colour temp. display, touch electronic
Door / side walls	stainless steel with SmartSteel / stainless steel with SmartSteel
Refrigerator temperature range °C	+2 °C to +9 °C
Freezer temperature range °C	-14 °C to -26 °C
Temperature alarm	visual and acoustic
Defrost type	automatic
Interior light	LED ceiling lighting with dimmer function
Door alarm	visual and acoustic
IceMaker	fixed water connection 3/4"
Ice cube output kg/24h	1.2
SoftSystem	yes
Door hinges	left / right
Product dimensions (H/W/D) cm	185 / 121 / 66.5
Net weight kg	163.6
Voltage V/Hz	220 - 240/50



### Installation Diagram (mm)

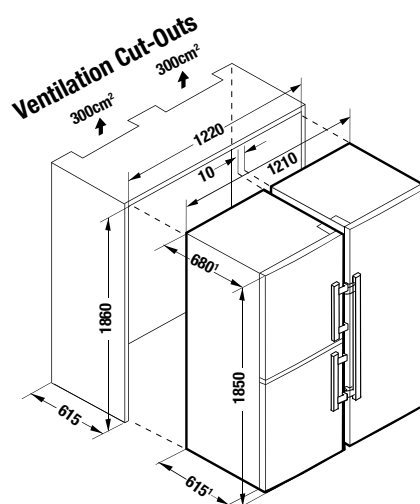
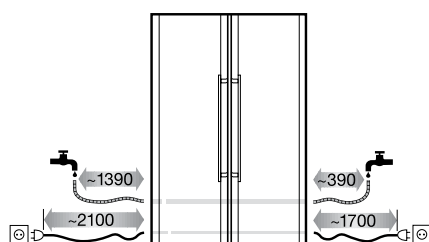



←121→



### SBSes 8683 PremiumPlus

Energy consumption (kWh/yr)   Star rating	211   5.0 (left) 194   4.0 (right)
Refrigerator capacity litre	366
BioFresh comp. litre	132
Freezer capacity litre	262
Number of shelves (including divisible shelf)	6
Number of door racks & bins	5
Number of BioFresh drawers	3 with LED lighting
Number of freezer drawers	9
Electronic control	2.4" TFT-colour temp. display, touch electronic
Door / side walls	stainless steel with SmartSteel / stainless steel with SmartSteel
Refrigerator temperature range °C	+2°C to +9°C
Freezer temperature range °C	-14°C to -28°C
Temperature alarm	visual and acoustic
Defrost type	automatic
Interior light	LED interior lighting / LED ceiling lighting with dimmer function
Door alarm	visual and acoustic
IceMaker	fixed water connection 3/4"
Ice cube output kg/24h	0.8
SoftSystem	yes
Door hinges	left / right
Product dimensions (H/W/D) cm	185 / 121 / 66.5
Net weight kg	164
Voltage V/Hz	220 - 240/50



#### Installation Diagram (mm)

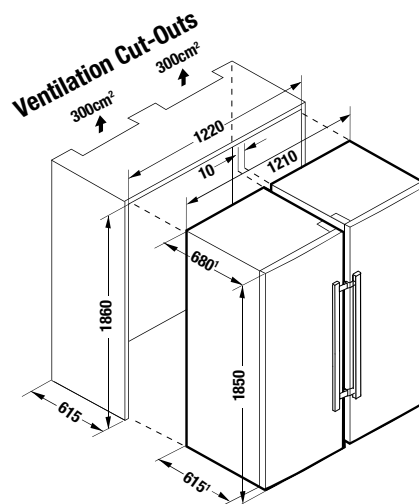
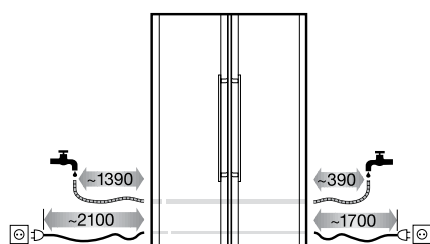

## Freestanding



### SBSbs 8673 Premium



Energy consumption (kWh/yr)   Star rating	211   5.0 (left) 194   4.0 (right)
Refrigerator capacity litre	367
BioFresh comp. litre	133
Freezer capacity litre	262
Number of shelves (including divisible shelf)	6
Number of door racks & bins	5
Number of BioFresh drawers	3 with LED lighting
Number of freezer drawers	9
Electronic control	2.4" TFT-colour temp. display, touch electronic
Door / side walls	BlackSteel with SmartSteel / BlackSteel with SmartSteel
Refrigerator temperature range °C	+2 °C to +9 °C
Freezer temperature range °C	-14 °C to -28 °C
Temperature alarm	visual and acoustic
Defrost type	automatic
Interior light	LED interior lighting
Door alarm	visual and acoustic
IceMaker	fixed water connection 3/4"
Ice cube output kg/24h	0.8
SoftSystem	yes
Door hinges	left / right
Product dimensions (H/W/D) cm	185 / 121 / 66.5
Net weight kg	164.5
Voltage V/Hz	220 - 240/50



### Installation Diagram (mm)

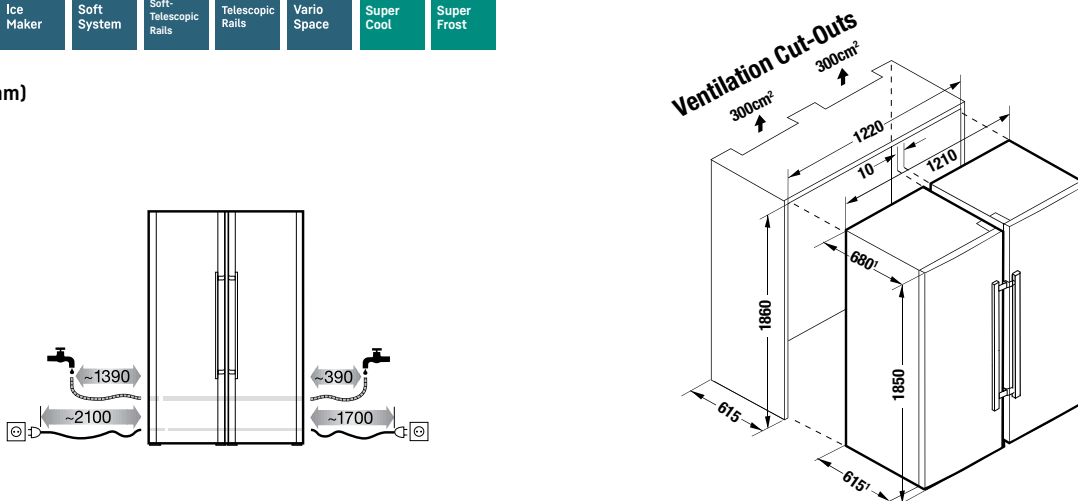



**SBSes 8673**  
Premium



Energy consumption (kWh/yr)   Star rating	211   5.0 (left) 194   4.0 (right)
Refrigerator capacity litre	367
BioFresh comp. litre	133
Freezer capacity litre	262
Number of shelves (including divisible shelf)	6
Number of door racks & bins	5
Number of BioFresh drawers	3 with LED lighting
Number of freezer drawers	9
Electronic control	2.4" TFT-colour temp. display, touch electronic
Door / side walls	stainless steel with SmartSteel / stainless steel with SmartSteel
Refrigerator temperature range °C	+2 °C to +9 °C
Freezer temperature range °C	-14 °C to -28 °C
Temperature alarm	visual and acoustic
Defrost type	automatic
Interior light	LED interior lighting
Door alarm	visual and acoustic
IceMaker	fixed water connection 3/4"
Ice cube output kg/24h	0.8
SoftSystem	yes
Door hinges	left / right
Product dimensions (H/W/D) cm	185 / 121 / 66.5
Net weight kg	164
Voltage V/Hz	220 - 240/50



Installation Diagram (mm)

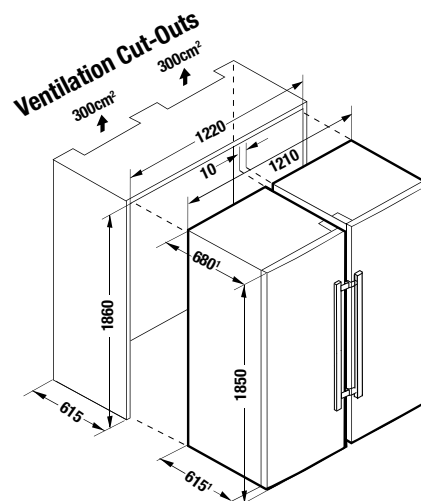
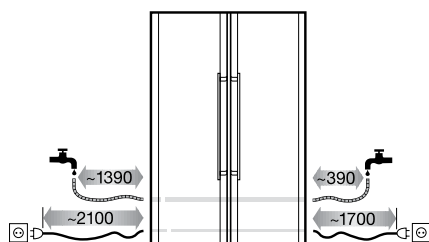

## Freestanding



### SBSef 7242

Comfort

Energy consumption (kWh/yr)   Star rating	310   3.5 (left) 279   2.5 (right)
Refrigerator capacity litre	381
Freezer capacity litre	253
Number of shelves	7
Number of door racks	5
Number of fruit and vegetable drawers	2
Number of freezer drawers	8
Electronic control	MagicEye with digital temp. display, touch electronic
Door / side walls	stainless steel with SmartSteel / silver
Refrigerator temperature range °C	+1°C to +9°C
Freezer temperature range °C	-14°C to -26°C
Temperature alarm	visual and acoustic
Defrost type	automatic
Interior light	LED ceiling lighting
Door alarm	acoustic
Door hinges	left / right
Product dimensions (H/W/D) cm	185.2 / 121 / 62.3
Net weight kg	151.5
Voltage V/Hz	220 - 240 / 50



### Installation Diagram (mm)

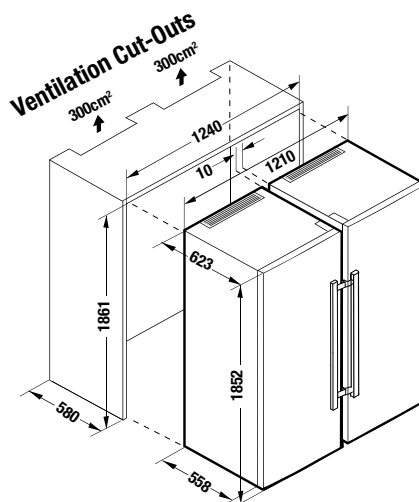



**CNPef 4516**  
Comfort

Energy consumption (kWh/yr)   Star rating	342   3.5
Refrigerator capacity litre	333
Freezer capacity litre	89
Number of shelves	4
Number of door racks	4
Number of freezer drawers	2
Number of fruit and vegetable drawers	2 with LED lighting
Electronic control	MagicEye with LCD temp. display, touch electronic
Door / side walls	stainless steel with SmartSteel / silver
Refrigerator temperature range °C	+2 °C to +7 °C
Freezer temperature range °C	-14 °C to -27 °C
Temperature alarm	visual and acoustic
Defrost type	automatic
Interior light	LED ceiling lighting
Door alarm	acoustic
Door hinges	right, reversible
Product dimensions (H/W/D) cm	185.9 / 74.7 / 63
Net weight kg	95
Voltage V/Hz	220 - 240/50



**CNPef 4416**  
Comfort

Energy consumption (kWh/yr)   Star rating	262   4.5
Refrigerator capacity litre	279
Freezer capacity litre	89
Number of shelves	4
Number of door racks	4
Number of fruit and vegetable drawers	2
Number of freezer drawers	2 with LED lighting
Electronic control	MagicEye with digital temp. display, touch electronic
Door / side walls	stainless steel with SmartSteel / silver
Refrigerator temperature range °C	+2 °C to +7 °C
Freezer temperature range °C	-14 °C to -27 °C
Temperature alarm	visual and acoustic
Defrost type	automatic
Interior light	LED ceiling lighting
Door alarm	acoustic
Door hinges	right, reversible
Product dimensions (H/W/D) cm	168.4 / 75 / 63
Net weight kg	87
Voltage V/Hz	220 - 240/50



Installation Diagram (mm)

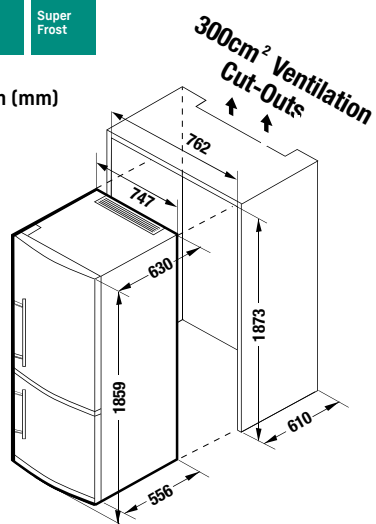

Installation Diagram (mm)

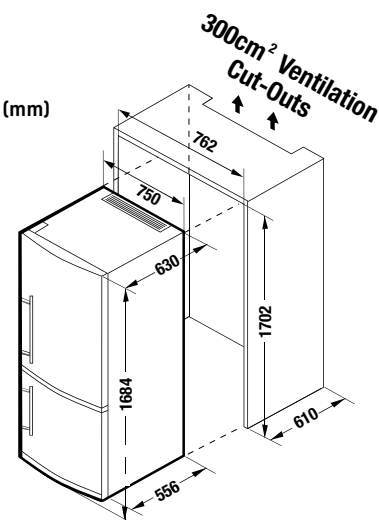



## CNef 4315

Comfort



Energy consumption (kWh/yr)   Star rating	187   6
Refrigerator capacity litre	230
Freezer capacity litre	120
Number of shelves	4
Number of door racks	3
Number of freezer drawers	3
Number of BioCool drawers	1
Electronic control	2.4" TFT-monochrome temp. display, touch electronic
Door / side walls	stainless steel with SmartSteel / silver
Refrigerator temperature range °C	+1°C to +9°C
Freezer temperature range °C	-14°C to -26°C
Temperature alarm	visual and acoustic
Defrost type	automatic
Interior light	LED ceiling lighting
Door alarm	visual and acoustic
Door hinges	right, reversible
Product dimensions (H/W/D) cm	185 / 60 / 66.5
Net weight kg	74.8
Voltage V/Hz	220 - 240/50



### Installation Diagram (mm)

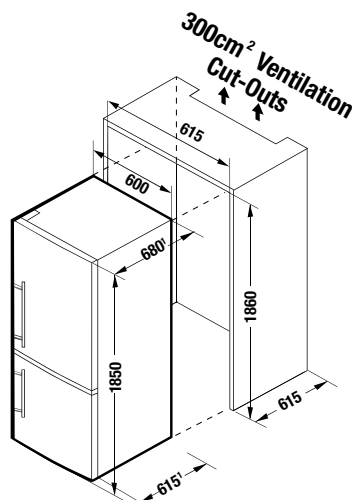

<sup>1</sup> Includes 15mm wall spacer fitted





## IRBPh 5170

Peak

Energy consumption (kWh/yr)   Star rating	121   5.0
Refrigerator capacity litre	297
BioFresh comp. litre	96
Number of OpenStage drawers	5
Number of BioFresh drawers	3 with LED lighting
Electronic control	2.4" TFT-colour display, Touch & Swipe
Refrigerator temperature range °C	+3°C to +9°C
Temperature alarm	visual and acoustic
Defrost type	automatic
Interior light	LED light panel on both sides
Door alarm	visual and acoustic
SoftSystem	yes
Door hinges	right, reversible
Product dimensions (H/W/D) cm	177 / 55.9 / 54.6
Cut out dimensions (H/W/D) cm	177.2-178.8 / 56-57 / 55
Net weight kg	74.0
Voltage V/Hz	220-240/50-60



### Installation Diagram

NB: The cupboard door is attached to the appliance door (door on door assembly).  
No cupboard hinges required.

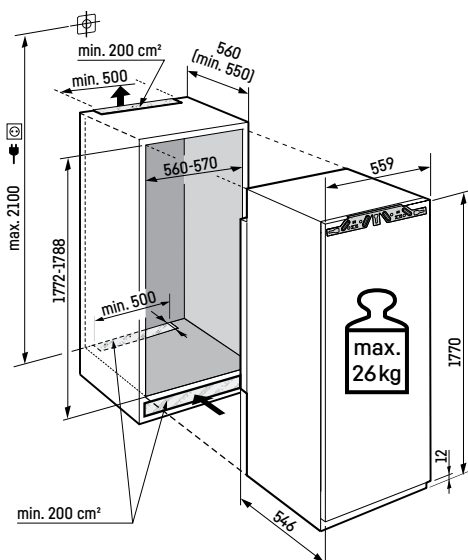

## Fully Integrated



↑  
178  
↓

### SIFNh 5188

Peak

Energy consumption (kWh/yr) I Star rating	207   4.0
Freezer capacity litre	213
Number of freezer drawers	8
Electronic control	2.4" TFT-colour display, Touch & Swipe
Freezer temperature range °C	-15 °C to -28 °C
Temperature alarm	visual and acoustic
Defrost type	automatic
Door alarm	visual and acoustic
SoftSystem	yes
Door hinges	left, reversible
Product dimensions (H/W/D) cm	177 / 55.9 / 54.6
Cut out dimensions (H/W/D) cm	177.2-178.8 / 56-57 / 55
Net weight kg	82.1
Voltage V/Hz	220-240/50-60



### Installation Diagram

NB: The cupboard door is attached to the appliance door (door on door assembly).  
No cupboard hinges required.

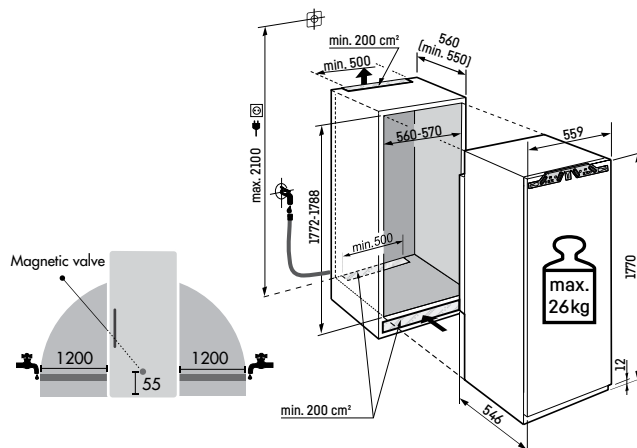



↑  
178  
↓

## IRBh 5170

Peak

Energy consumption (kWh/yr)   Star rating	106   6.0
Refrigerator capacity litre	293
BioFresh comp. litre	92
Number of shelves	8
Number of door racks	4
Number of BioFresh drawers	3 with LED lighting
Electronic control	2.4" TFT-colour display, Touch & Swipe
Refrigerator temperature range °C	+3°C to +9°C
Defrost type	automatic
Interior light	LED light panel on both sides
Door alarm	visual and acoustic
SoftSystem	yes
Door hinges	right, reversible
Product dimensions (H/W/D) cm	177 / 55.9 / 54.6
Cut out dimensions (H/W/D) cm	177.2-178.8 / 56-57 / 55
Net weight kg	73.5
Voltage V/Hz	220-240/50-60



### Installation Diagram

NB: The cupboard door is attached to the appliance door (door on door assembly). No cupboard hinges required.

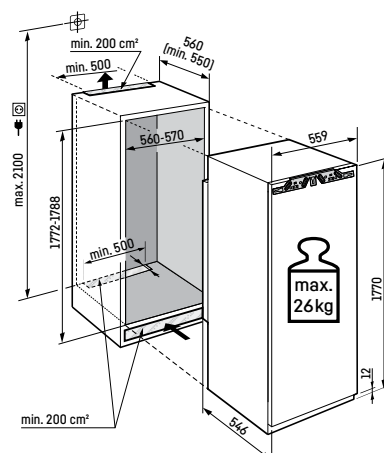

## Fully Integrated



↑  
178  
↓

### SIFNh 5128

Plus

Energy consumption (kWh/yr)   Star rating	207   4.0
Freezer capacity litre	213
Number of freezer drawers	8
Electronic control	LCD display monochrome, touch electronic
Freezer temperature range °C	-15 °C to -28 °C
Temperature alarm	visual and acoustic
Defrost type	automatic
Door alarm	visual and acoustic
SoftSystem	yes
Door hinges	left, reversible
Product dimensions (H/W/D) cm	177 / 55.9 / 54.6
Cut out dimensions (H/W/D) cm	177.2-178.8 / 56-57 / 55
Net weight kg	61.1
Voltage V/Hz	220-240/50-60



↑  
178  
↓

### IRBh 5120

Plus

Energy consumption (kWh/yr)   Star rating	110   5.5
Refrigerator capacity litre	294
BioFresh comp. litre	96
Number of shelves	7
Electronic control	LCD display monochrome, touch electronic
Refrigerator temperature range °C	+3 °C to +9 °C
Defrost type	automatic
Interior light	LED ceiling lighting
Door alarm	visual and acoustic
SoftSystem	yes
Door hinges	right, reversible
Product dimensions (H/W/D) cm	177 / 55.9 / 54.6
Cut out dimensions (H/W/D) cm	177.2-177.8 / 56-57 / 55
Net weight kg	61.8
Voltage V/Hz	220-240/50-60



#### Installation Diagram

NB: The cupboard door is attached to the appliance door (door on door assembly). No cupboard hinges required.

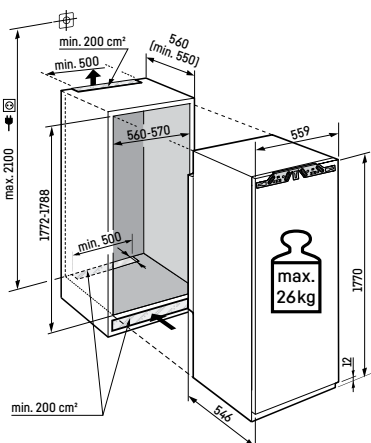

#### Installation Diagram

NB: The cupboard door is attached to the appliance door (door on door assembly). No cupboard hinges required.

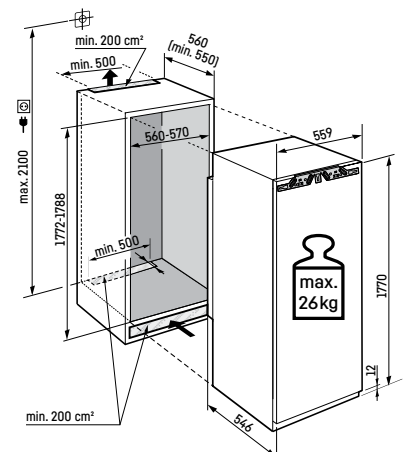



178

### ICBNh 5173

Peak

Energy consumption (kWh/yr)   Star rating	181   5.5
Refrigerator capacity litre	172
BioFresh comp. litre	69
Freezer capacity litre	67
Number of shelves	4
Number of door racks	2
Number of freezer drawers	3 with LED lighting
Number of BioFresh drawers	2 with LED lighting
Electronic control	2.4" TFT-colour display, Touch & Swipe
Refrigerator temperature range °C	+3°C to +9°C
Freezer temperature range °C	-15°C to -26°C
Temperature alarm	visual and acoustic
Defrost type	automatic
Interior light	LED light panel on both sides
Door alarm	visual and acoustic
IceMaker	fixed water connection 3/4"
Ice cube output kg/24h	1.2
SoftSystem	yes
Door hinges	left, reversible
Product dimensions (H/W/D) cm	177 / 55.9 / -
Cut out dimensions (H/W/D) cm	177.2-178.8 / 56-57 / 55
Net weight kg	76.6
Voltage V/Hz	220-240/50-60

Bio Fresh Professional	Hydro Breeze	Duo Cooling	No Frost	Super Cool	Super Frost	Soft System	Soft-Telescopic Rails	Touch & Swipe-Display
Vario Space	Glass & Steel Interior	Light Tower	Ice Maker					

#### Installation Diagram

NB: The cupboard door is attached to the appliance door (door on door assembly). No cupboard hinges required.

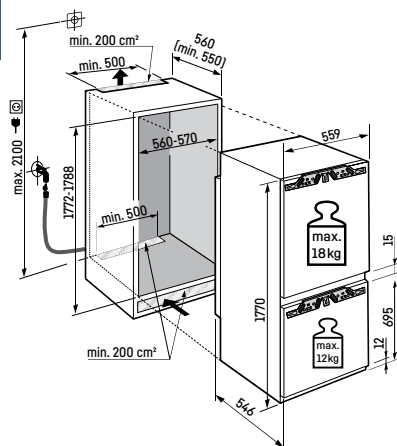
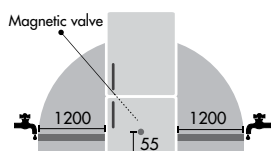

178

### ICNh 5173

Peak

Energy consumption (kWh/yr)   Star rating	176   5.5
Refrigerator capacity litre	174
Freezer capacity litre	69
Number of shelves	6
Number of door racks	3
Number of freezer drawers	3 with LED lighting
Number of EasyFresh drawers	1
Electronic control	2.4" TFT-colour display, Touch & Swipe
Refrigerator temperature range °C	+2°C to +9°C
Freezer temperature range °C	-15°C to -26°C
Temperature alarm	visual and acoustic
Defrost type	automatic
Interior light	LED light panel on both sides
Door alarm	visual and acoustic
SoftSystem	yes
Door hinges	right, reversible
Product dimensions (H/W/D) cm	177 / 55.9 / 54.6
Cut out dimensions (H/W/D) cm	177.2-178.8 / 56-57 / 55
Net weight kg	74
Voltage V/Hz	220-240/50/60

Easy Fresh	Duo Cooling	No Frost	Super Cool	Super Frost	Soft System	Touch & Swipe-Display	Vario Space	Glass & Steel Interior
Light Tower								

#### Installation Diagram

NB: The cupboard door is attached to the appliance door (door on door assembly). No cupboard hinges required.

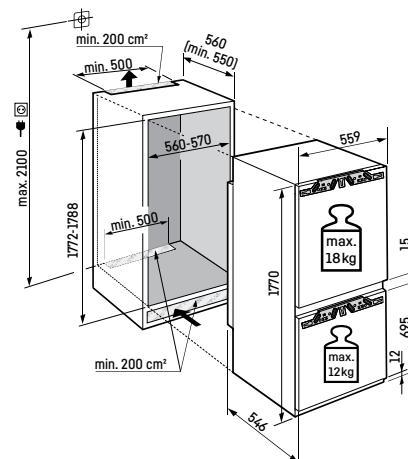

## Fully Integrated



↑  
178  
↓

### ICNh 5133

Plus

Energy consumption (kWh/yr)   Star rating	182   5.5
Refrigerator capacity litre	182
Freezer capacity litre	67
Number of shelves	6
Number of door racks	3
Number of freezer drawers	3
Number of EasyFresh drawers	1
Electronic control	LCD display monochrome, touch electronic
Refrigerator temperature range °C	+2 °C to +9 °C
Freezer temperature range °C	-15 °C to -26 °C
Temperature alarm	visual and acoustic
Defrost type	automatic
Interior light	LED ceiling lighting
Door alarm	visual and acoustic
IceMaker	watertank
Ice cube output kg/24h	1.2
SoftSystem	yes
Door hinges	right, reversible
Product dimensions (H/W/D) cm	177 / 55.9 / 54.6
Cut out dimensions (H/W/D) cm	177.2-178.8 / 56-57 / 55
Net weight kg	68.9
Voltage V/Hz	220-240/50-60



### Installation Diagram

NB: The cupboard door is attached to the appliance door (door on door assembly). No cupboard hinges required.

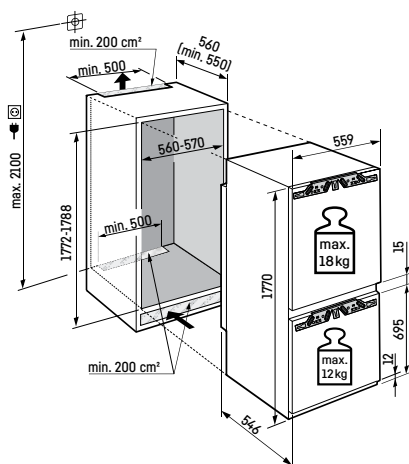

↑  
178  
↓

### ICNh 5123

Plus

Energy consumption (kWh/yr)   Star rating	176   5.5
Refrigerator capacity litre	182
Freezer capacity litre	69
Number of shelves	6
Number of door racks	3
Number of freezer drawers	3
Number of EasyFresh drawers	1
Electronic control	LCD display monochrome, touch electronic
Refrigerator temperature range °C	+2 °C to +9 °C
Freezer temperature range °C	-15 °C to -26 °C
Temperature alarm	visual and acoustic
Defrost type	automatic
Interior light	LED ceiling lighting
Door alarm	visual and acoustic
SoftSystem	yes
Door hinges	right, reversible
Product dimensions (H/W/D) cm	177 / 55.9 / 54.6
Cut out dimensions (H/W/D) cm	177.2-178.8 / 56-57 / 55
Net weight kg	66.9
Voltage V/Hz	220-240/50-60



### Installation Diagram

NB: The cupboard door is attached to the appliance door (door on door assembly). No cupboard hinges required.

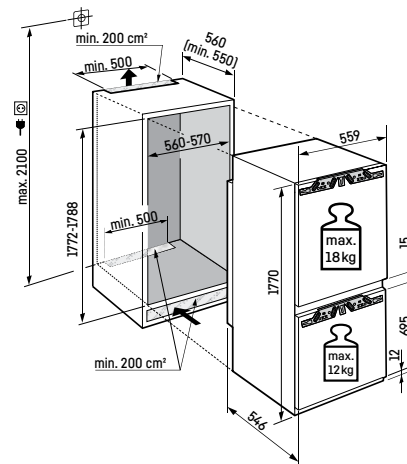



## ICNh 5103

Pure

Energy consumption (kWh/yr)   Star rating	175   5.5
Refrigerator capacity litre	251
Freezer capacity litre	69
Number of shelves	4
Number of door racks	3
Number of freezer drawers	3
Number of EasyFresh drawers	1
Electronic control	LCD display monochrome, touch electronic
Refrigerator temperature range °C	+2 °C to +9 °C
Freezer temperature range °C	-15 °C to -26 °C
Defrost type	automatic
Interior light	LED ceiling lighting
Door alarm	visual and acoustic
Door hinges	right, reversible
Product dimensions (H/W/D) cm	177 / 55.9 / 54.6
Cut out dimensions (H/W/D) cm	177.2-178.8 / 56-57 / 55
Net weight kg	64.5
Voltage V/Hz	220-240/50-60



### Installation Diagram

NB: The cupboard door is attached to the appliance door (door on door assembly).  
No cupboard hinges required.

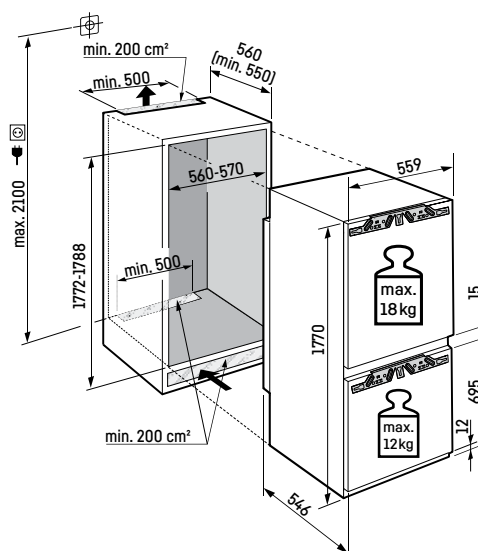

## Fully Integrated



**ECBN 6256**  
PremiumPlus

Energy consumption (kWh/yr)   Star rating	487   2.5
Refrigerator capacity litre	357
BioFresh comp. litre	68
Freezer capacity litre	114
Number of shelves / Number of door racks	4 / 6
Number of freezer drawers	2 with LED lighting
Number of BioFresh drawers	2 with LED lighting
Electronic control	<b>MagicEye with digital temp. display, touch electronic</b>
Refrigerator temperature range °C	+3°C to +9°C
Freezer temperature range °C	-14°C to -28°C
Temperature alarm	<b>visual and acoustic</b>
Defrost type	<b>automatic</b>
Interior light	<b>LED light column on both sides and LED ceiling lighting</b>
Door alarm	<b>acoustic</b>
Water filter	<b>yes</b>
IceMaker	<b>fixed water connection 3/4"</b>
Ice cube output kg/24h	1.3
SoftSystem	<b>yes</b>
Door hinges	<b>left / right</b>
Product dimensions (H/W/D) cm	202.7 / 91 / 61
Cut out dimensions (H/W/D) cm	203.2-207.2 / 91.5 / 63.5
Net weight kg	161
Voltage V/Hz	220 - 240/50



**ECBN 6156**  
PremiumPlus

Energy consumption (kWh/yr)   Star rating	496   3.0
Refrigerator capacity litre	364
BioFresh comp. litre	69
Freezer capacity litre	116
Number of shelves	4
Number of door racks	6
Number of freezer drawers	2 with LED lighting
Number of BioFresh drawers	2 with LED lighting
Electronic control	<b>MagicEye with digital temp. display, touch electronic</b>
Refrigerator temperature range °C	+3°C to +9°C
Freezer temperature range °C	-14°C to -28°C
Temperature alarm	<b>visual and acoustic</b>
Defrost type	<b>automatic</b>
Interior light	<b>LED light column on both sides and LED ceiling lighting</b>
Door alarm	<b>acoustic</b>
Water filter	<b>yes</b>
IceMaker	<b>fixed water connection 3/4"</b>
Ice cube output kg/24h	1.3
Door hinges	<b>right</b>
Product dimensions (H/W/D) cm	202.7 / 91 / 61
Cut out dimensions (H/W/D) cm	203.2-207.2 / 91.5 / 63.5
Net weight kg	164
Voltage V/Hz	220 - 240/50



### Installation Diagram

Reinforced flexible hose (3m) for appliances with a 3/4" plumbed-in connection.

NB: The cupboard door is attached to the appliance door (door on door assembly). No cupboard hinges required.

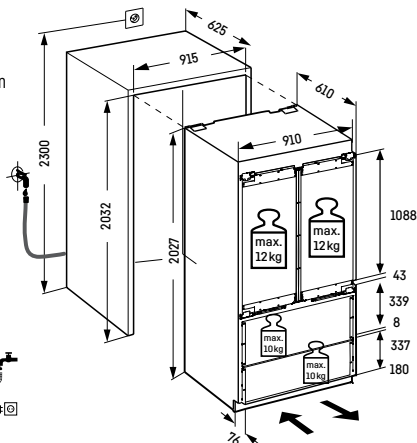
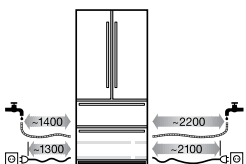

### Installation Diagram

Reinforced flexible hose (3m) for appliances with a 3/4" plumbed-in connection.

NB: The cupboard door is attached to the appliance door (door on door assembly). No cupboard hinges required.

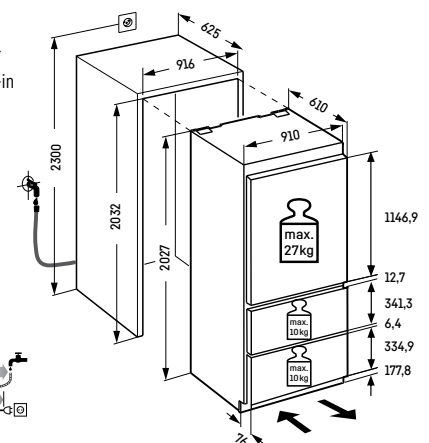
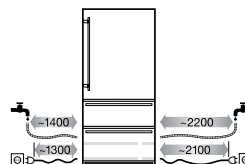





**ECBN 5066**  
PremiumPlus

Energy consumption (kWh/yr)   Star rating	304   4.5
Refrigerator capacity litre	276
BioFresh comp. litre	57
Freezer capacity litre	103
Number of shelves	4
Number of door racks	3
Number of freezer drawers	2 with LED lighting
Number of BioFresh drawers	2 with LED lighting
Electronic control	MagicEye with digital temp. display, touch electronic
Refrigerator temperature range °C	+3°C to +9°C
Freezer temperature range °C	-14°C to -28°C
Temperature alarm	visual and acoustic
Defrost type	automatic
Interior light	LED light column on both sides
Door alarm	acoustic
Water filter	yes
IceMaker	fixed water connection 3/4"
Ice cube output kg/24h	1.0
Door hinges	right, reversible
Product dimensions (H/W/D) cm	202.4 / 75.7 / 61
Cut out dimensions (H/W/D) cm	203.2-207.2 / 76.2 / 63.5
Net weight kg	147
Voltage V/Hz	220-240/50



### Installation Diagram

Reinforced flexible hose (3m) for appliances with a 3/4" plumbed-in connection.

NB: The cupboard door is attached to the appliance door (door on door assembly).  
No cupboard hinges required.

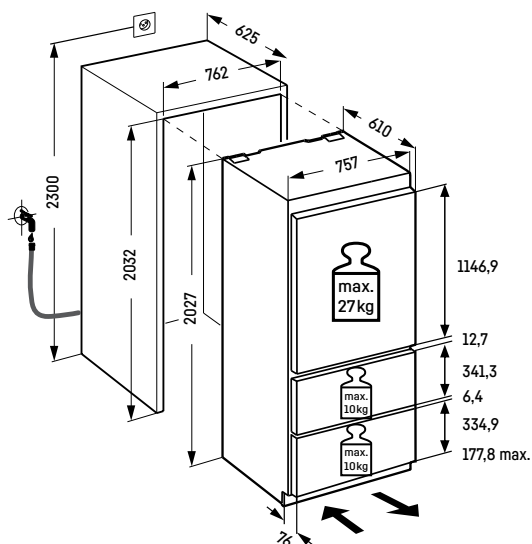
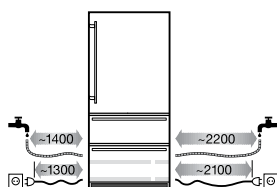

# Undercounter



## SUIKo 1550 Premium

Energy consumption (kWh/yr) I Star rating	158   3.5
Refrigerator capacity litre	124
Number of shelves	2
Number of fruit and vegetable drawers	1
Electronic control	MagicEye with LCD temp. display, key electronic
Refrigerator temperature range °C	+2 °C to +9 °C
Defrost type	automatic
Interior light	LED ceiling lighting
Door alarm	visual and acoustic
Door type	steel
Door hinges	pullout
Product dimensions (H/W/D) cm	82 / 59.7 / 55
Cut out dimensions (H/W/D) cm	82-88 / 60 / 55
Net weight kg	41.5
Voltage V/Hz	220-240/50



### Installation Diagram

NB: The cupboard door is attached to the appliance door (door on door assembly).  
 No cupboard hinges required.  
 Plinth height at appliance height of 820 mm (height of worktop 850 mm) adjustable between 100 and 160 mm, or between 163 and 223 mm at appliance height of 880 mm (height of worktop 900 mm). Depth of plinth 22-77 mm.

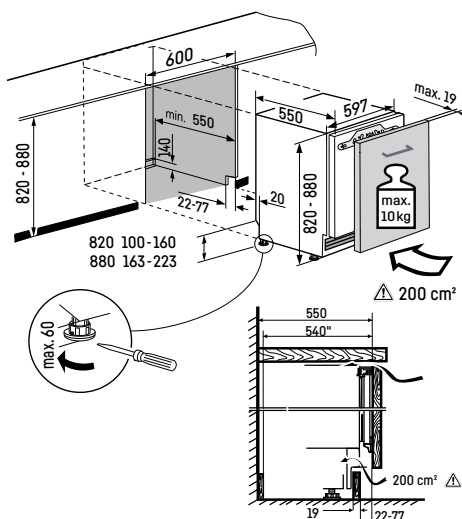



## SUIG 1514

Comfort

Energy consumption (kWh/yr)   Star rating	168   4.0
Freezer capacity litre	95
Number of freezer drawers	3
Electronic control	<b>MagicEye with LCD temp. display, key electronic</b>
Freezer temperature range °C	-14 °C to -26 °C
Temperature alarm	<b>visual and acoustic</b>
Defrost type	<b>manual</b>
Door alarm	<b>visual and acoustic</b>
Door type	<b>steel</b>
SoftSystem	<b>yes</b>
Door hinges	<b>left, reversible</b>
Product dimensions (H/W/D) cm	<b>82 / 59.7 / 55</b>
Cut out dimensions (H/W/D) cm	<b>82-88 / 60 / 55</b>
Net weight kg	<b>38.2</b>
Voltage V/Hz	<b>220-240/50</b>



## SUIK 1510

Comfort

Energy consumption (kWh/yr)   Star rating	147   3.5
Refrigerator capacity litre	136
Number of shelves	4
Number of door racks	2
Number of fruit and vegetable drawers	1
Electronic control	<b>MagicEye with LCD temp. display, key electronic</b>
Refrigerator temperature range °C	+2 °C to +9 °C
Defrost type	<b>automatic</b>
Interior light	<b>LED interior lighting</b>
Door alarm	<b>visual and acoustic</b>
Door type	<b>steel</b>
SoftSystem	<b>yes</b>
Door hinges	<b>right, reversible</b>
Product dimensions (H/W/D) cm	<b>82 / 59.7 / 55</b>
Cut out dimensions (H/W/D) cm	<b>82-88 / 60 / 55</b>
Net weight kg	<b>34.5</b>
Voltage V/Hz	<b>220-240/50/60</b>



### Installation Diagram

NB: The cupboard door is attached to the appliance door (door on door assembly). No cupboard hinges required. Plinth height at appliance height of 820 mm (height of worktop 850 mm) adjustable between 100 and 160 mm, or between 163 and 223 mm at appliance height of 880 mm (height of worktop 900 mm). Depth of plinth 22-77 mm.

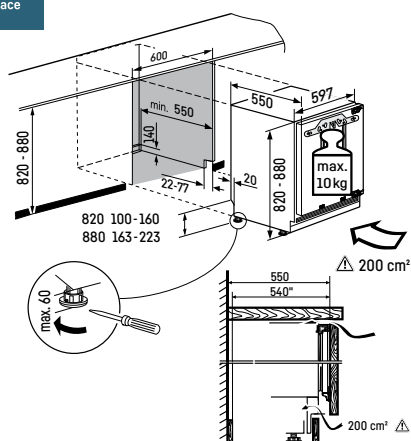

### Installation Diagram

NB: The cupboard door is attached to the appliance door (door on door assembly). No cupboard hinges required. Plinth height at appliance height of 820 mm (height of worktop 850 mm) adjustable between 100 and 160 mm, or between 163 and 223 mm at appliance height of 880 mm (height of worktop 900 mm). Depth of plinth 22-77 mm.

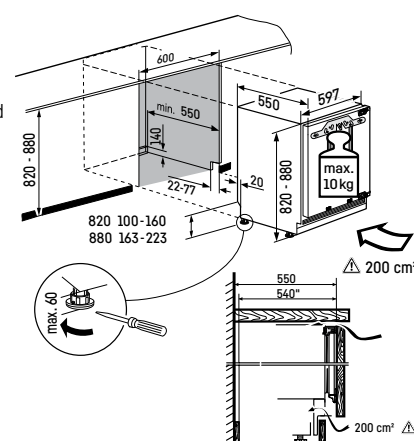

# Wine Cabinets



**WTeS 5872**  
Vinidor

Total capacity litre	<b>511</b>
Max. No. of Bordeaux bottles (0.75l) *	<b>178</b>
Total no. of storage shelves (incl. bottom compartment)	<b>13</b>
Shelves on telescopic rails	<b>10</b>
Shelf material	<b>beech wood shelves</b>
Presentation shelf	<b>1</b>
Electronic control	<b>LCD temp. display for 3 wine zones, touch electronic</b>
Temperature range °C	<b>+5°C to +20°C</b>
Temperature zones	<b>3</b>
Temperature alarm	<b>visual and acoustic</b>
Interior light	<b>LED lighting permanently on, dimmable</b>
Door alarm	<b>acoustic</b>
Safety thermostat	<b>yes</b>
Activated Charcoal filter	<b>yes</b>
Door type	<b>glass door with stainless steel frame</b>
Integrated lock	<b>yes</b>
SoftSystem	<b>yes</b>
Door hinges	<b>right, reversible</b>
Product dimensions (H/W/D) cm	<b>192 / 70 / 74.2</b>
Net weight kg	<b>136</b>
Voltage V/Hz	<b>220-240/50</b>



**WTeS 5972**  
Vinidor

Total capacity litre	<b>526</b>
Max. No. of Bordeaux bottles (0.75l) *	<b>211</b>
Total no. of storage shelves (incl. bottom compartment)	<b>10</b>
Shelves on telescopic rails	<b>8</b>
Shelf material	<b>beech wood shelves</b>
Presentation shelf	<b>1</b>
Electronic control	<b>LCD temp. display for both wine zones, touch electronic</b>
Temperature range °C	<b>+5°C to +20°C</b>
Temperature zones	<b>2</b>
Temperature alarm	<b>visual and acoustic</b>
Interior light	<b>LED lighting permanently on, dimmable</b>
Door alarm	<b>acoustic</b>
Safety thermostat	<b>yes</b>
Activated Charcoal filter	<b>yes</b>
Door type	<b>glass door with stainless steel frame</b>
Integrated lock	<b>yes</b>
Door hinges	<b>right, reversible</b>
Product dimensions (H/W/D) cm	<b>192 / 70 / 74.2</b>
Net weight kg	<b>125</b>
Voltage V/Hz	<b>220-240/50</b>

- 3 Zones
- Humidity Select
- Fresh Air
- UV Protect
- Vibrate Safe
- Soft System
- Telescopic Rails
- Presentation Board
- LED

Steel Interior

### Installation Diagram

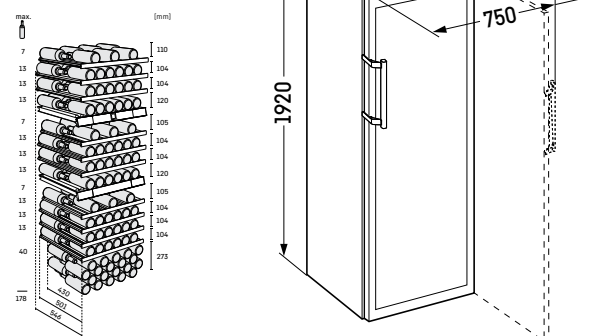

- 2 Zones
- Humidity Select
- Fresh Air
- UV Protect
- Vibrate Safe
- Telescopic Rails
- Presentation Board
- LED
- Steel Interior

### Installation Diagram

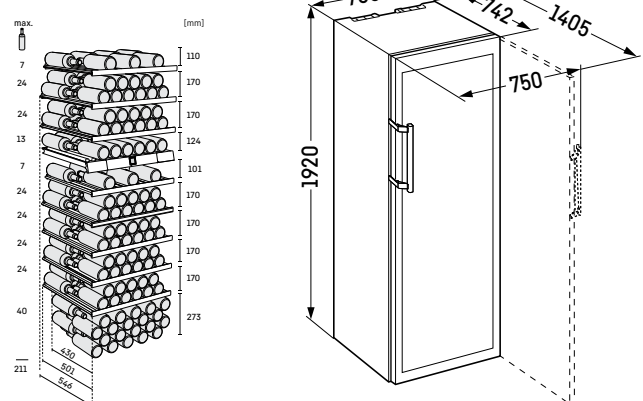

\*These models are only bound for storing wine. Maximum DIN norm bordeaux bottles capacity (0.75 l) as per norm NF H 35-124 (H: 300.5 mm, Ø 76.1 mm).



**Wkt 6451**  
GrandCru

Total capacity litre	625
Max. No. of Bordeaux bottles (0.75l) *	312
Total no. of storage shelves (incl. bottom compartment)	7
Shelf material	beech wood shelves
Electronic control	MagicEye with digital temp. display, key electronic
Temperature range °C	+5 °C to +20 °C
Temperature zones	1
Temperature alarm	visual and acoustic
Interior light	LED interior lighting
Door alarm	acoustic
Safety thermostat	yes
Activated Charcoal filter	yes
Door type	full door, terra
Integrated lock	yes
Door hinges	right, reversible
Product dimensions (H/W/D) cm	193 / 74.7 / 75.9
Net weight kg	87
Voltage V/Hz	220-240/50

- 1 Zone
- Humidity Select
- Fresh Air
- Vibrate Safe
- LED
- Steel Interior

**Installation Diagram**

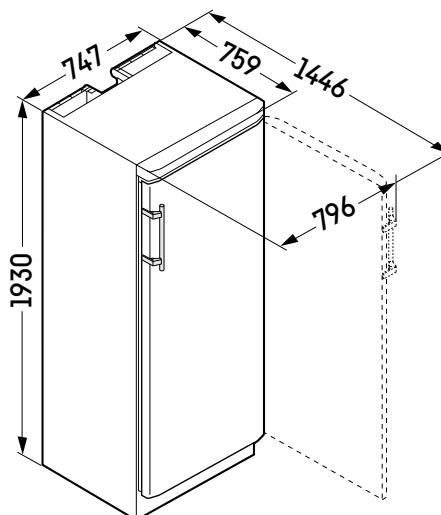
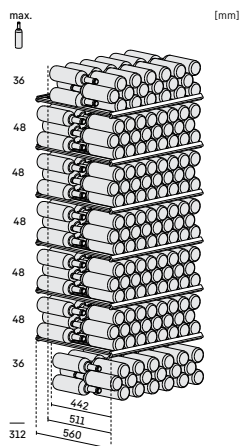

# Wine Cabinets



↑  
178  
↓

**EWTdf 3553**  
Vinidor

Total capacity litre	<b>256</b>
Max. No. of Bordeaux bottles (0.75l) *	<b>80</b>
Total no. of storage shelves (incl. bottom compartment)	<b>10</b>
Shelves on telescopic rails	<b>8</b>
Shelf material	<b>beech wood shelves</b>
Presentation shelf	<b>1</b>
Electronic control	<b>LCD temp. display for both wine zones, touch electronic</b>
Temperature range °C	<b>+5°C to +20 °C</b>
Temperature zones	<b>2</b>
Temperature alarm	<b>visual and acoustic</b>
Interior light	<b>LED lighting permanently on, dimmable</b>
Door alarm	<b>acoustic</b>
Safety thermostat	<b>yes</b>
Activated Charcoal filter	<b>yes</b>
Door type	<b>panel ready or stainless steel panel as accessory</b>
SoftSystem	<b>yes</b>
Door hinges	<b>right, reversible</b>
Product dimensions (H/W/D) cm	<b>177 / 55.7 / 55.3</b>
Cut out dimensions (H/W/D) cm	<b>177.2-178 / 56-57 / 55</b>
Net weight kg	<b>91</b>
Voltage V/Hz	<b>220-240/50/60</b>



↑  
178  
↓

**EWTgb 3583**  
Vinidor

Total capacity litre	<b>271</b>
Max. No. of Bordeaux bottles (0.75l) *	<b>83</b>
Total no. of storage shelves (incl. bottom compartment)	<b>10</b>
Shelves on telescopic rails	<b>8</b>
Shelf material	<b>beech wood shelves</b>
Presentation shelf	<b>1</b>
Electronic control	<b>LCD temp. display for both wine zones, touch electronic</b>
Temperature range °C	<b>+5°C to +20 °C</b>
Temperature zones	<b>2</b>
Temperature alarm	<b>visual and acoustic</b>
Interior light	<b>LED lighting permanently on, dimmable</b>
Door alarm	<b>acoustic</b>
Safety thermostat	<b>yes</b>
Activated Charcoal filter	<b>yes</b>
Door type	<b>Black glass</b>
SoftSystem	<b>yes</b>
Door hinges	<b>right, reversible</b>
Product dimensions (H/W/D) cm	<b>177 / 55.7 / 55.3</b>
Cut out dimensions (H/W/D) cm	<b>177.2-178 / 56-57 / 55</b>
Net weight kg	<b>90</b>
Voltage V/Hz	<b>220-240/50/60</b>



## Installation Diagram

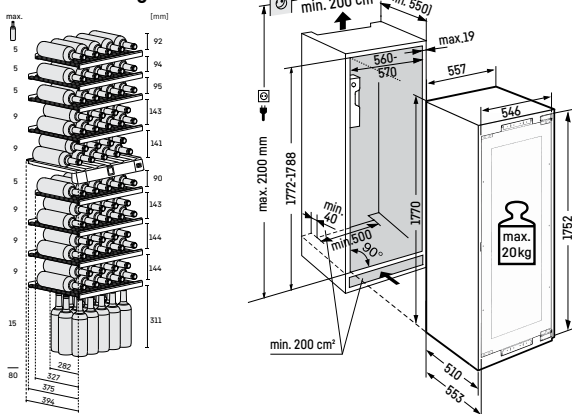

## Installation Diagram

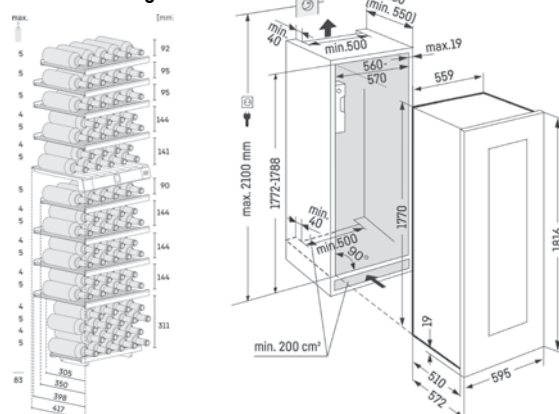



### UWTeS 1672

Vinidor

Total capacity litre	94
Max. No. of Bordeaux bottles (0.75l) *	34
Total no. of storage shelves (incl. bottom compartment)	5
Shelves on telescopic rails	3
Shelf material	beech wood shelves
Electronic control	MagicEye with digital temp. display for both wine zones, key electronic
Temperature range °C	+5 °C to +20 °C
Temperature zones	2
Temperature alarm	visual and acoustic
Interior light	LED lighting permanently on, dimmable
Door alarm	acoustic
Safety thermostat	yes
Activated Charcoal filter	yes
Door type	glass door with stainless steel frame
Integrated lock	yes
Door hinges	right, reversible
Product dimensions (H/W/D) cm	81.8 / 59.7 / 57.7
Cut out dimensions (H/W/D) cm	82-87 / 60 / 58
Net weight kg	48
Voltage V/Hz	220-240/50



### UWKeS 1752

GrandCru

Total capacity litre	112
Max. No. of Bordeaux bottles (0.75l) *	46
Total no. of storage shelves (incl. bottom compartment)	4
Shelves on telescopic rails	3
Shelf material	beech wood shelves
Electronic control	MagicEye with digital temp. display, key electronic
Temperature range °C	+5 °C to +20 °C
Temperature zones	1
Temperature alarm	visual and acoustic
Interior light	LED lighting permanently on
Door alarm	acoustic
Safety thermostat	yes
Activated Charcoal filter	yes
Door type	glass door with stainless steel frame
Integrated lock	yes
Door hinges	right, reversible
Product dimensions (H/W/D) cm	81.8 / 59.7 / 57.7
Cut out dimensions (H/W/D) cm	82-87 / 60-61 / 58
Net weight kg	44
Voltage V/Hz	220-240/50

- 2 Zones
- Humidity Select
- Fresh Air
- Telescopic Rails
- LED
- Steel Interior

#### Installation Diagram

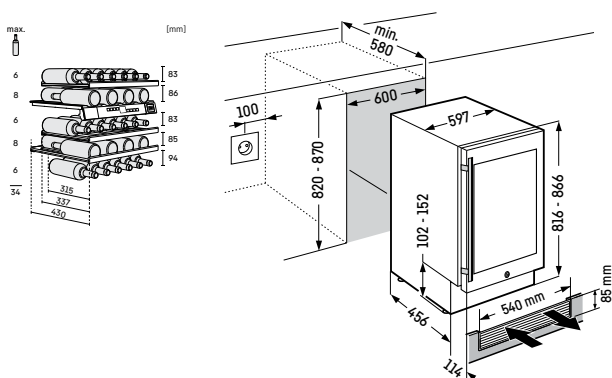

- 1 Zone
- Humidity Select
- Fresh Air
- Telescopic Rails
- LED
- Steel Interior

#### Installation Diagram

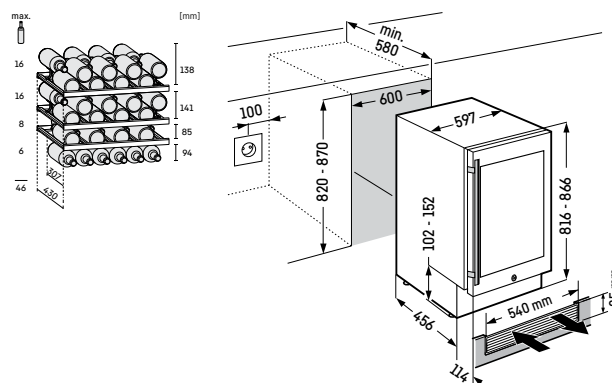

## Liebherr Barrique Wine Cabinets



← 66 →

### WKb 4612

Barrique

Total capacity litre	<b>336</b>
Max. No. of Bordeaux bottles (0.75l) *	<b>195</b>
Total no. of storage shelves (incl. bottom compartment)	<b>7</b>
Shelves on telescopic rails	<b>1</b>
Shelf material	<b>beech wood shelves</b>
Presentation shelf	<b>1</b>
Electronic control	<b>MagicEye with digital temp. display, key electronic</b>
Temperature range °C	<b>+5°C to +20°C</b>
Temperature zones	<b>1</b>
Temperature alarm	<b>visual and acoustic</b>
Interior light	<b>LED interior lighting</b>
Door alarm	<b>acoustic</b>
Safety thermostat	<b>yes</b>
Activated Charcoal filter	<b>yes</b>
Door type	<b>insulated glazed door, black frame</b>
Integrated lock	<b>yes</b>
Door hinges	<b>right, reversible</b>
Product dimensions (H/W/D) cm	<b>184.2 / 65.7 / 66.3</b>
Net weight kg	<b>86</b>
Voltage V/Hz	<b>220-240/50</b>



← 66 →

### WKb 4611

Barrique

Total capacity litre	<b>336</b>
Max. No. of Bordeaux bottles (0.75l) *	<b>195</b>
Total no. of storage shelves (incl. bottom compartment)	<b>7</b>
Shelf material	<b>beech wood shelves</b>
Electronic control	<b>MagicEye with digital temp. display, key electronic</b>
Temperature range °C	<b>+5°C to +20°C</b>
Temperature zones	<b>1</b>
Temperature alarm	<b>visual and acoustic</b>
Interior light	<b>light bulb</b>
Door alarm	<b>acoustic</b>
Safety thermostat	<b>yes</b>
Activated Charcoal filter	<b>yes</b>
Door type	<b>full door with handle, black</b>
Integrated lock	<b>yes</b>
Door hinges	<b>right, reversible</b>
Product dimensions (H/W/D) cm	<b>184.2 / 65.7 / 66.3</b>
Net weight kg	<b>68.5</b>
Voltage V/Hz	<b>220-240/50</b>



#### Installation Diagram

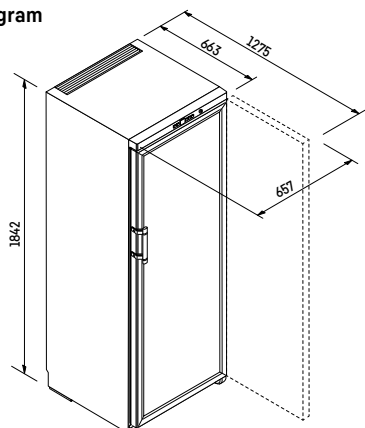

#### Installation Diagram

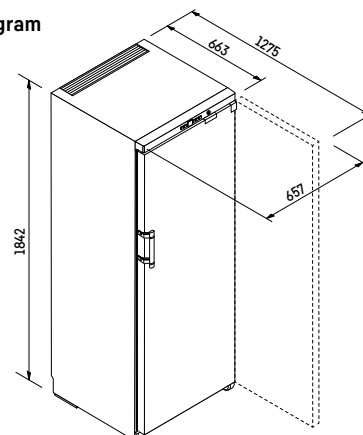





← 66 →

**WKgb 4113**  
Barrique

Total capacity litre	293
Max. No. of Bordeaux bottles (0.75l) *	168
Total no. of storage shelves (incl. bottom compartment)	6
Shelf material	beech wood shelves
Electronic control	MagicEye with digital temp. display, key electronic
Temperature range °C	+5 °C to +20 °C
Temperature zones	1
Temperature alarm	visual
Interior light	LED lighting permanently on
Door alarm	acoustic
Safety thermostat	yes
Activated Charcoal filter	yes
Door type	full glass door with heating function
Integrated lock	yes
Door hinges	right, reversible
Product dimensions (H/W/D) cm	164.5 / 65.7 / 66.3
Net weight kg	78
Voltage V/Hz	220-240/50



**Installation Diagram**

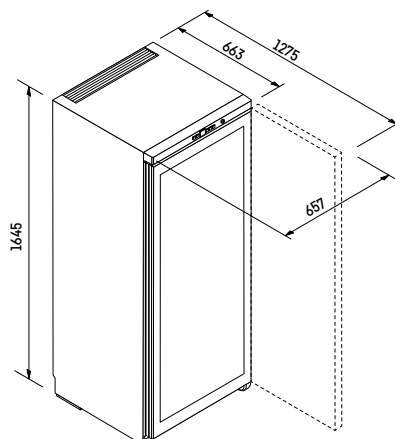

## Liebherr Barrique Wine Cabinets



**WKb 4112**  
Barrique

Total capacity litre	293
Max. No. of Bordeaux bottles (0.75l) *	168
Total no. of storage shelves (incl. bottom compartment)	6
Shelves on telescopic rails	1
Shelf material	beech wood shelves
Presentation shelf	1
Electronic control	MagicEye with digital temp. display, key electronic
Temperature range °C	+5°C to +20°C
Temperature zones	1
Temperature alarm	visual and acoustic
Interior light	LED interior lighting
Door alarm	acoustic
Safety thermostat	yes
Activated Charcoal filter	yes
Door type	insulated glazed door, black frame
Integrated lock	yes
Door hinges	right, reversible
Product dimensions (H/W/D) cm	164.5 / 65.7 / 66.3
Net weight kg	78
Voltage V/Hz	220-240/50



### Installation Diagram

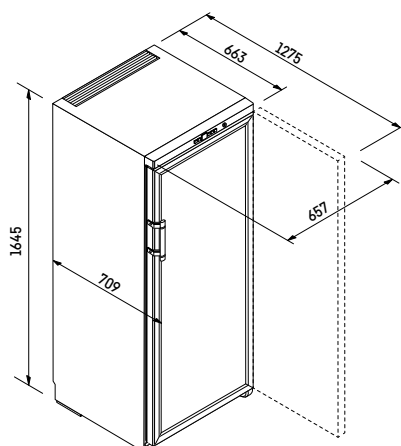



**WKb 1712**  
Barrique

Total capacity litre	121
Max. No. of Bordeaux bottles (0.75l) *	60
Total no. of storage shelves (incl. bottom compartment)	3
Shelf material	beech wood shelves
Electronic control	MagicEye with digital temp. display, key electronic
Temperature range °C	+5 °C to +20 °C
Temperature zones	1
Temperature alarm	visual and acoustic
Interior light	LED interior lighting
Door alarm	acoustic
Safety thermostat	yes
Activated Charcoal filter	yes
Door type	insulated glazed door, black frame
Integrated lock	yes
Door hinges	right, reversible
Product dimensions (H/W/D) cm	85 / 65.7 / 66.3
Net weight kg	45
Voltage V/Hz	220-240/50



**Installation Diagram**

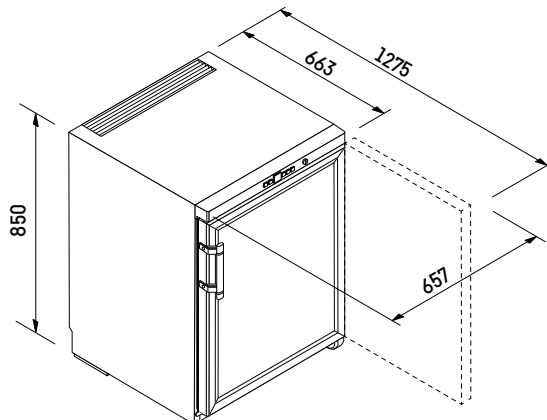

\* These models are only bound for storing wine. Maximum DIN norm bordeaux bottles capacity (0.75 l) as per norm NF H 35-124 (H: 300.5 mm, Ø 76.1 mm).

Hydro  
Breeze



Andi-Co Australia

Head Office  
1 Stamford Road, Oakleigh Victoria 3166  
E-mail: sales@andico.com.au | Tel: 1800 685 899



Visit our social media channels at  
[socialmedia.home.liebherr.com](https://socialmedia.home.liebherr.com)

[home.liebherr.com.au](https://home.liebherr.com.au)

Products and their details are staged for advertising purposes. Whilst every effort is made to ensure all specifications and information in this flyer are accurate, Liebherr reserves the right to make changes without notification. Where actual appliance measurements, specifications, and ratings are crucial, we recommend that the actual appliance installation instructions that accompany each appliance be checked. Liebherr will not be liable for any loss. (220921)

Subject to modification. Current data see home.liebherr.com.  
Printed in 2023.