



Installation Guide

Quality, Design and Innovation



home.liebherr.com/fridge-manuals



LIEBHERR

General safety instructions

Contents

1	General safety instructions.....	2
2	Installation conditions.....	2
2.1	Location.....	2
2.2	Installing multiple appliances.....	2
2.3	Mains connection.....	3
3	Appliance dimensions.....	3
4	Recess dimensions.....	4
4.1	Internal dimensions.....	4
5	Ventilation requirements.....	4
6	Transporting the appliance.....	5
7	Unpacking the appliance.....	5
8	Setting up the appliance.....	5
8.1	After installation.....	5
9	Disposing of packaging.....	5
10	What the symbols mean.....	5
11	**** freezer compartment door.....	6
11.1	Moving the door hinge.....	6
12	Reversing the door.....	7
13	Water connection*.....	9
14	Connecting the water supply.....	9
15	Installing the appliance in the recess.....	10
16	Cabinet fronts.....	16
16.1	Dimensions.....	16
16.2	Mounting the cabinet front(s).....	17
16.3	Setting the clearance to avoid collision.....	17
17	Water tank.....	18
17.1	Inserting the water tank.....	18
18	Connecting the appliance.....	18

The manufacturer works constantly on the further development of all the types and models. Therefore please understand that we have to reserve the right to make design, equipment and technical modifications.



To get to know all the benefits of your new appliance, please read the information contained in these instructions carefully.

The instructions apply to several models. Differences may occur. Text relating only to specific appliances is marked with an asterisk (*).

Instructions are marked with a ►, and results are marked with a ▷.

1 General safety instructions

- Only install, connect and dispose of the appliance according to the instructions.
- The socket must be easily accessible so that the appliance can be quickly disconnected from the supply in an emergency. It must be outside the area of the rear of the appliance.

	DANGER	identifies a situation involving direct danger which, if not obviated, may result in death or severe bodily injury.
	WARNING	identifies a dangerous situation which, if not obviated, may result in death or severe bodily injury.

	CAUTION	identifies a dangerous situation which, if not obviated, may result in minor or medium bodily injury.
	NOTICE	identifies a dangerous situation which, if not obviated, may result in damage to property.
	Note	identifies useful information and tips.

2 Installation conditions



WARNING

Fire hazard due to dampness!

If live parts or the mains lead become damp this may cause short circuits.

- The appliance is designed for use in enclosed areas. Do not operate the appliance outdoors or in areas where it is exposed to splash water or damp conditions.

Intended use

- Install and use the appliance in indoor spaces only.
- Use the appliance only once installed.

2.1 Location



WARNING

Leaking coolant and oil!

Fire. The coolant contained in the appliance is eco-friendly, but also flammable. The oil contained in the appliance is flammable. Escaping coolant and oil can ignite if the concentration is high enough and in contact with an external heat source.

- Do not damage the pipelines of the coolant circuit and the compressor.

- If the appliance is installed in a very humid environment, condensation can build up on the outside of the unit. Always make sure the installation location is well ventilated .
- The more coolant there is in the appliance, the larger the room in which the appliance is installed must be. If the room is too small, any leak may create a flammable mixture of gas and air. For each 8 g of coolant the installation space must be at least 1 m³. Information on the coolant is on the model plate inside the appliance.

2.1.1 Supporting floor

- The floor of the installation site must be horizontal and even.
- If the floor is not entirely even, the kitchen cabinet housing the appliance must be levelled with support blocks.

2.1.2 Positioning

- Do not install the appliance in direct sunlight, next to an oven, radiator or similar.
- Only fit the appliance into solid kitchen units.

2.2 Installing multiple appliances

NOTICE

Risk of damage due to condensate!

- Do not install the appliance directly alongside a further refrigerator/freezer.

NOTICE

Risk of damage due to condensation!

- ▶ Do not install the appliance directly above another refrigerator or freezer.

These appliances are designed for a variety of installation options. Combine appliances only if the appliance is suitable. The following table shows the installation options by model:

Installation option	Model
Single	All models
Side-by-side (SBS)	Model names starting with S... See the supplied SBS installation guide for the correct positioning.
Stacked	Models with a maximum recess height of 880 mm and with a heated cover can be "stacked". Top appliance: up to a maximum recess height of 140 mm



Fig. 1

Build each appliance into a separate recess.

2.3 Mains connection



WARNING

Improper use!

Fire. If a mains cable/plug comes into contact with the back of the appliance, the mains cable/plug can be damaged by appliance vibrations and this may result in a short circuit.

- ▶ Stand the appliance so that it is not touched by connectors or main cables.
- ▶ Do not connect any appliances to sockets in the area of the back of the appliance.
- ▶ Multi-sockets/power distributors and other electronic appliances (such as halogen transformers) may not be placed and operated at the back of appliances.

3 Appliance dimensions



Fig. 2

	A (mm)	B (mm)	C (mm)	D (mm)	E (mm)
ICB/b/c/i/d/ 51..				549	
IC/e/d51..	/ 559	546	1770	695	15
S/ICN/f/d/e/i51..	/				
ICBN/c/e/l/d/51..					

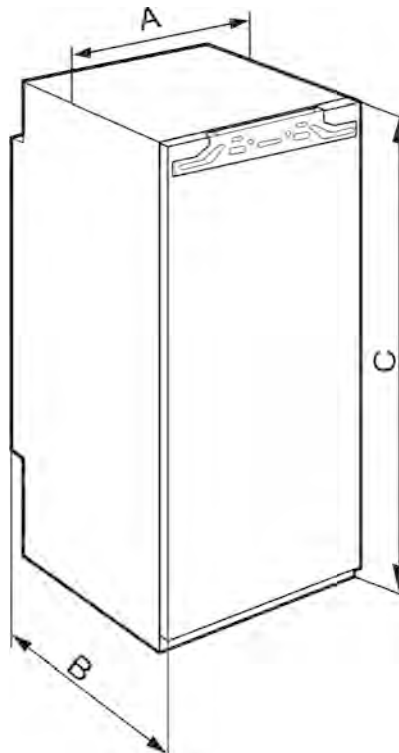

Fig. 3

Recess dimensions

	A (mm)	B (mm)	C (mm)
IFNe 35..	559	546	712
IR/f/e/d/c39.. SIBa 39../IFN/e/ d39..			872
IRe40../ IRBd40..			1022
IR/e/ d41../IRB/b/d/ i41../SIFNd 41..			1213
IRe45../ IRBd45../SIFNd 45..			1395
IRBe48..			1572
IR/f/e51../ IRD/c/e/d/i/51.. / IRBPdi51../ SIFn/f/h/e/i 51..			1770

	F (mm)*	G (mm)*	H (mm)*	J (mm)*	L (mm)*
IFNe 35..	714 -730	560 — 570	min. 550, recom- mended: 560	min. 500	max. 19
IR/f/e/d/ c39.. SIBa39../ IF/Se39../ IFNe/d 39..	874 — 890				
IRe 40../ IRBd 40..	1024 — 1040				
IR/e/d 41../IRB/b/ d/i 41.. / SIFNd 41.	1216 — 1236				
IRe 45../ IRBd 45.. / SIFNd 45..	1397 — 1413				
IRBe 48..	1574 — 1590				
IR/f/e 51../ IRD/c/e/d/i/ 51.. / IC/e/d 51.. / S/ICN/f/d/e /i 51.. / ICB/N/c/e/l /d/ 51.. / IRBPdi 51../ SIFN/St/e/ ei/h/hi/	1772 — 1788				

4 Recess dimensions

4.1 Internal dimensions

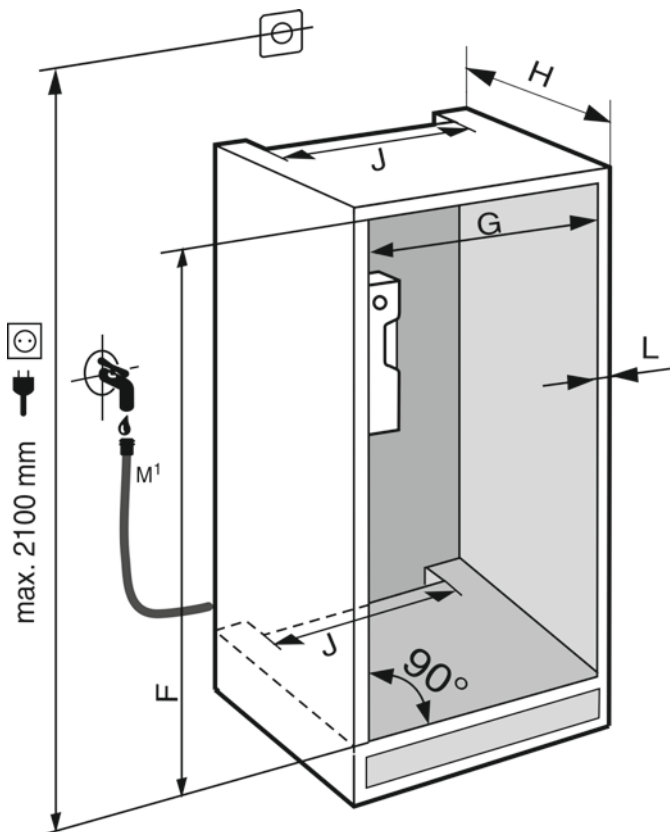

Fig. 4*

M¹): Only for IRBdi 5180/5190, ICNdi 5173, ICBNd/i 5163/73/83, ICBdi 5182*

The specified energy consumption was determined with a kitchen unit depth of 560 mm. The appliance will work properly at a kitchen unit depth of 550 mm, but with a slightly higher energy consumption.

- ▶ Check the wall thickness of adjacent cabinets: It must be min. 16 mm.
- ▶ Only fit the appliance into stable, solid kitchen units. Secure the unit against tipping.
- ▶ Align the cabinets with a spirit level and a try square. If necessary level them by putting something underneath them.
- ▶ Ensure that the floor and the side panels of the cabinet are at right angles to each other.

5 Ventilation requirements

NOTICE

Covered vents!

Damage. Appliance can overheat, which can reduce the service life of various parts of the appliance and lead to operational impairments.

- ▶ Always make sure there is good ventilation.
- ▶ Always keep vents or ventilation grids in the appliance housing and in the kitchen furniture (fully integrated appliance) unobstructed.
- ▶ Always keep the fan air vents unobstructed.

Always follow the required ventilation gaps:

- The depth of the ventilation shaft at the back of the cabinet must be at least 38 mm.

- At least 200 cm² is required for the ventilation cross-sections below the unit at its base and above the unit in the surrounding cabinet.
- As a rule, the larger the ventilation cross-section, the more efficiently the appliance will run.

Sufficient ventilation is required for the operation of the appliance. The provided ventilation grids ensure an effective ventilation gap on the appliance of 200 cm². If you replace the ventilation grids with a panel this must have the same size or larger ventilation gap than the grid provided by the manufacturer.

6 Transporting the appliance

- ▶ Transport the appliance only in suitable packaging.
- ▶ Transport the appliance upright.
- ▶ Do not transport the appliance on your own.

7 Unpacking the appliance

Before you connect the appliance, report any damage immediately to the delivery company.

- ▶ Check the appliance and the packaging for damage during transport. Contact the supplier immediately if you suspect any level of damage.
- ▶ Remove all materials from the back or the side walls of the appliance that may prevent proper installation or ventilation.
- ▶ Remove all protective films from the appliance. Do not use sharp or pointed objects for this.
- ▶ Take the power cable from the rear of the appliance. Remove the cable brackets when you do this, otherwise there will be noise caused by vibrations!

8 Setting up the appliance



CAUTION

Risk of injury!

- ▶ The appliance must be transported to its place of installation by two people.



WARNING

Unstable appliance!

Risk of injury and damage. The appliance can topple over.

- ▶ Attach the appliance according to the operating instructions.



WARNING

Fire hazard and danger of damage!

- ▶ Do not place appliances emitting heat e.g. microwaves, toasters etc. on the appliance!

If possible, have the appliance installed in the kitchen unit by a professional.

Do not install the appliance on your own.

8.1 After installation

- ▶ Remove all transport safety components.

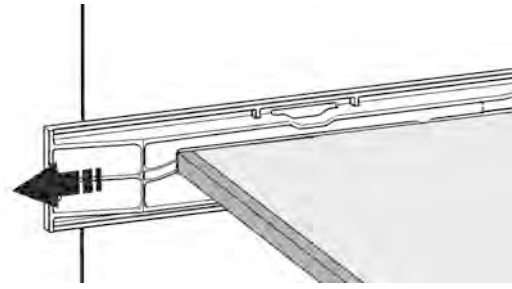
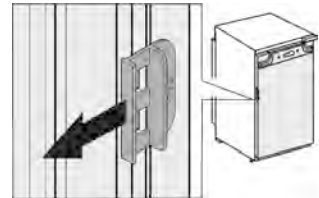
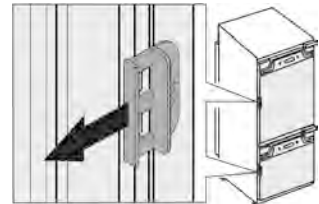

Fig. 5*



- ▶ Remove the red transport safety device.



- ▶ Clean the appliance (see User Guide, Cleaning the appliance).

9 Disposing of packaging



WARNING

Danger of suffocation due to packing material and plastic film!

- ▶ Do not allow children to play with packing material.

The packaging is made of recyclable materials:

- corrugated board/cardboard
- expanded polystyrene parts
- polythene bags and sheets
- polypropylene straps
- nailed wooden frame with polyethylene panel*













- ▶ Take the packaging material to an official collecting point.



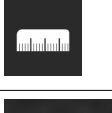
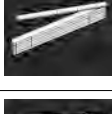



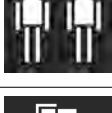

10 What the symbols mean

	Risk of injury here! Follow the safety notes!
	These instructions apply to a range of models. Follow this step only if it applies to your appliance.
	To install, please follow the detailed description in the Guide.
	This section applies either to a single-door appliance or a double-door appliance.

**** freezer compartment door

	Choose one of the options: Appliance with right-hinged door or appliance with left-hinged door.
	Installation step required if your model has IceMaker and/or InfinitySpring.
	Just loosen the screws or tighten them slightly.
	Tighten the screws.
	Check to see if the next step applies for your model.
	Check the correct assembly/seat of the components used.
	Measure the specified measurement and adjust if necessary.
	Tool for assembly: Metre rule
	Tool for assembly: Cordless screwdriver and attachments
	Tool for assembly: Spirit level
	Tool for assembly: Size 7 and size 10 spanners
	Two people are required for this step.
	Carry out this step at the marked place on the appliance.
	Aids for assembly: String

	Aids for assembly: Square
	Aids for assembly: Screwdriver
	Aids for assembly: Scissors
	Aids for assembly: Non-permanent marker pen
	Accessory kit: Remove components
	Dispose of components that are no longer needed.

11 **** freezer compartment door

The **** freezer compartment door can be easily moved whenever changing the door hinge. If the door of the refrigerator can be opened more than 115° (1), the freezer compartment can also be opened without changing the hinge. If the opening angle (2) of the appliance door is less than this, the door hinge must be repositioned.

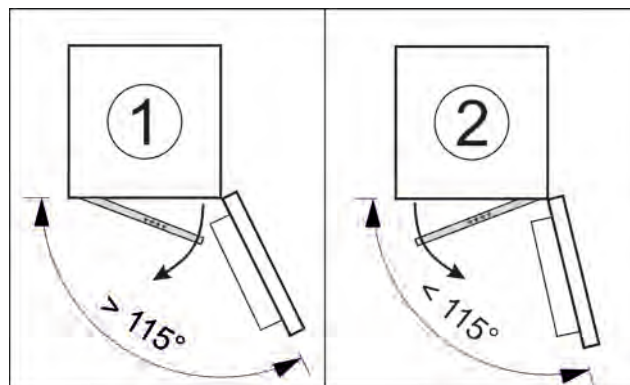
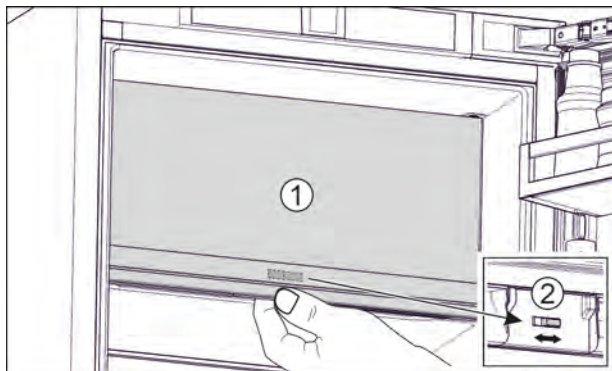

Fig. 6*

11.1 Moving the door hinge

The slider for moving the door hinge is located on the back of the **** freezer compartment door at the bottom.



- Fig. 7*
- ▶ Close the **** freezer compartment door (1).
 - ▶ Grab the **** freezer compartment door from below.
 - ▶ Slide the slider (2) either to the right or to the left.

12 Reversing the door

Tool



Fig. 8

NOTICE

Live parts

Damage to electrical parts

- ▶ Before changing the door hinge, disconnect the plug at the mains.

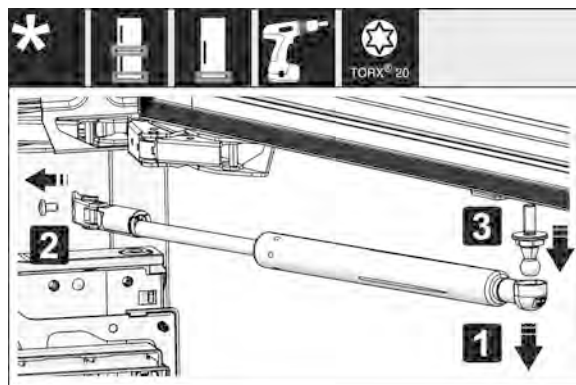

Fig. 9

- ▶ Removing the soft stop damper: Remove the soft stop damper from the ball stud (1). Unscrew the retainer (2). Remove the ball stud with a screwdriver (3).

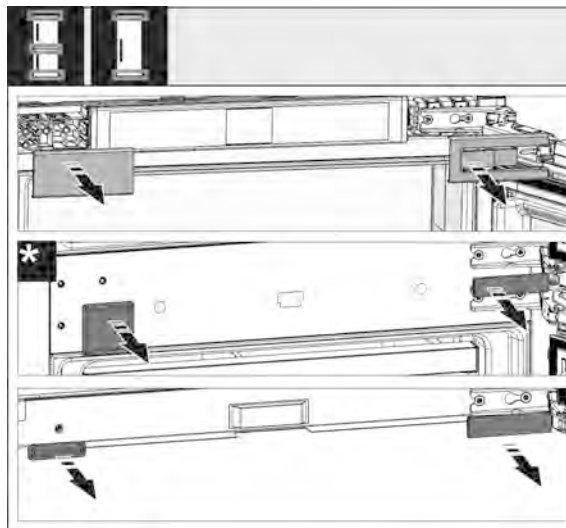

Fig. 10

- ▶ Remove covers.

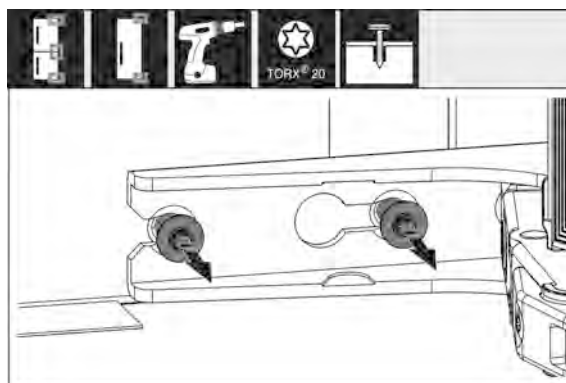
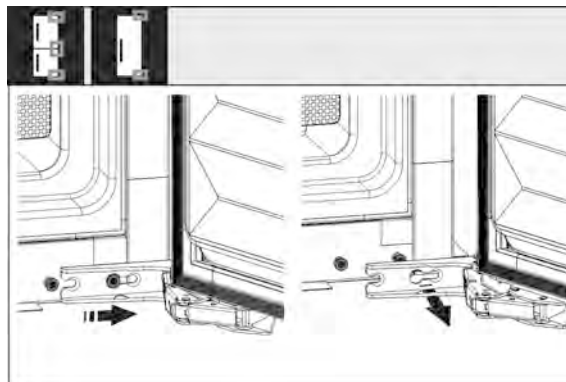

Fig. 11

- ▶ Loosen the screws on **all** hinges but do not remove them.



*Fig. 12**

- ▶ Removing the door: Push the door forward and then out, unhook it and put it to one side.

Reversing the door

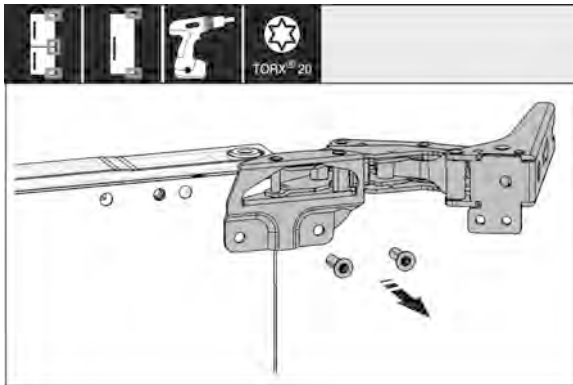

Fig. 13

- Unscrew all hinges and set aside together with the screws.

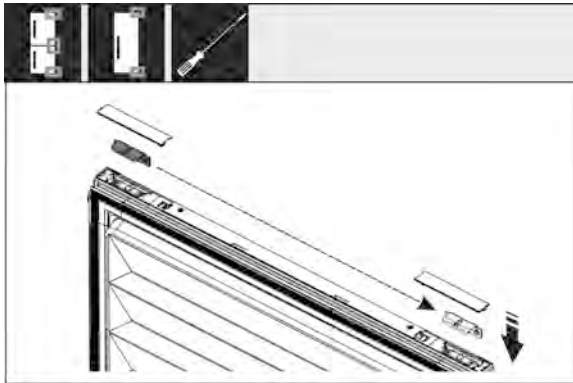

Fig. 14

- Loosen and shift the bracket at the top and bottom of the door. The bracket must be shifted so you can screw on the hinges.

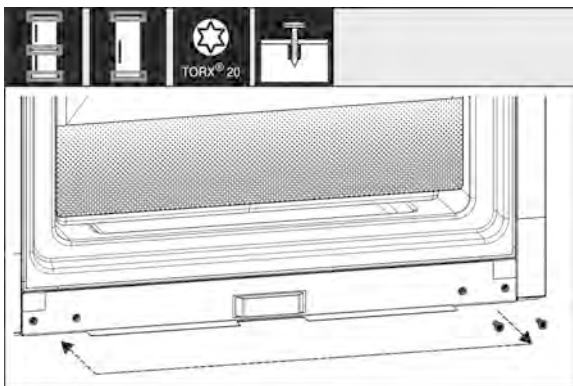

Fig. 15

- Shift the screws to fasten the hinge. Do not screw tightly after shifting – you need to hang the hinges later.

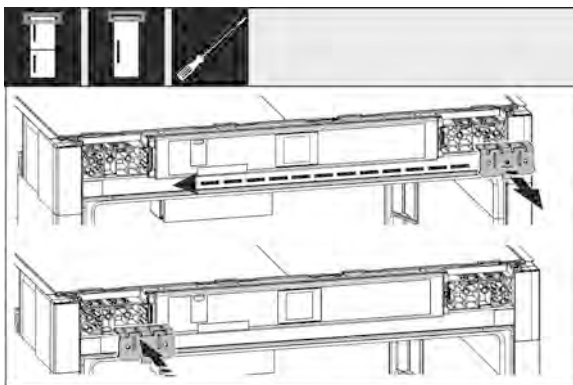

Fig. 16

- Move the fixing bracket to the opposite side.

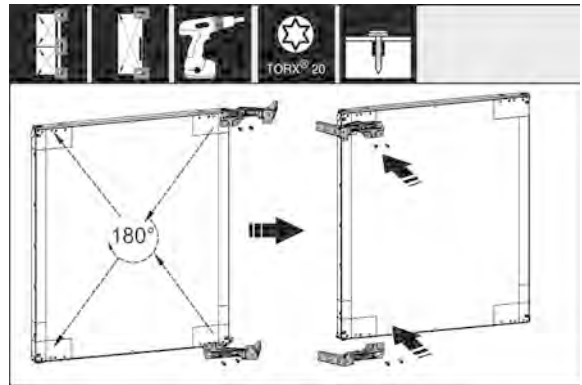

Fig. 17

- Turn all hinges 180° to the opposite side and screw firmly.

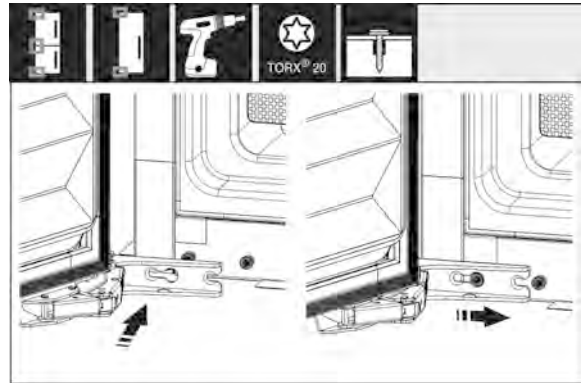

Fig. 18*

- Refitting the door: Hang the door with its hinges and tighten the screws.

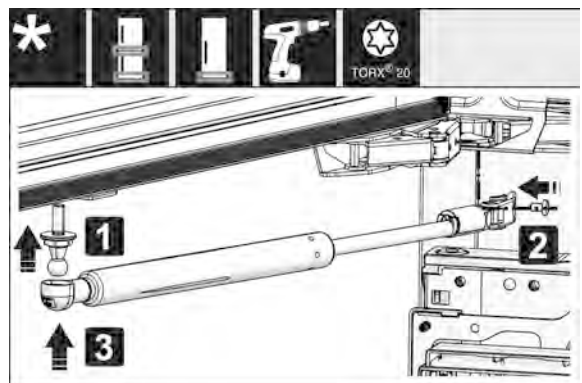

Fig. 19

- Refitting the closing dampers: Screw in the ball studs (1), tighten the bracket (2) and hang the closing dampers in the ball studs.
- Check all screws and retighten if necessary.

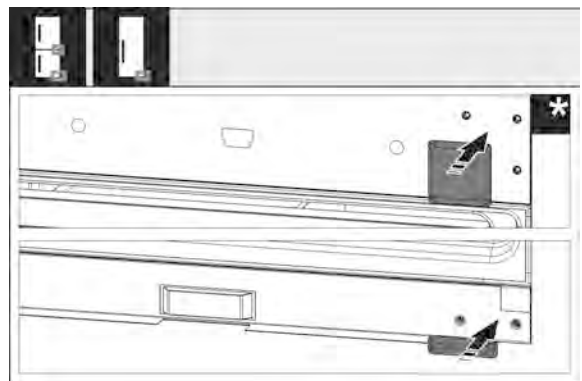

Fig. 20

- ▶ Reassemble the bottom and centre cover. Only replace the remaining covers after installing the appliance back into the cabinet.

13 Water connection*



WARNING

Electricity in combination with water!
Electric shock.

- ▶ Before connecting to the water pipe: Disconnect the appliance from the mains.
- ▶ Before connecting to water supply lines: Shut off the water supply.
- ▶ The connection to the drinking water mains may only be carried out by a qualified gas and water engineer.



WARNING

Unclean water!
Contaminants.

- ▶ Only connect to the drinking water supply.

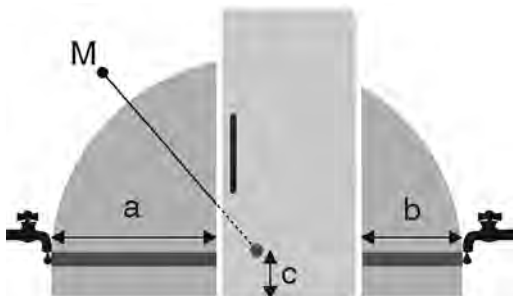

Fig. 21

a	b	c	M
~ 1200 mm	~ 1200 mm	~ 55 mm	Solenoid valve

The appliance's water connection and inlet solenoid valve are suitable for a water pressure of up to 1 MPa (10 bar).

Specifications for proper operation (flow rate, ice cube size, noise level):

Water pressure:	
bars	MPa
1.5 - 6.2	0.15 - 0.62

Water pressure when using the water filter:	
bars	MPa
2.8 - 6.2	0.28 - 0.62

If the pressure exceeds 0.62 MPa (6.2 bar): Activate the pressure reducer first.

Ensure that the following conditions are met:

- Water pressure is maintained.
- Water is supplied to the appliance via a cold water pipe which can withstand the operating pressure and is connected to the drinking water supply.
- Enclosed hose is used. Old hoses are disposed of.
- A filter with a seal is located in the hose connector.
- A stopcock must be provided between the hose line and the domestic water connection to cut off the water supply if necessary.

- The stopcock must be located outside the back of the appliance and within easy reach so that the appliance can be placed as far back as possible and the stopcock can be turned off quickly. Distances are adhered to.
- All devices and equipment used to supply water must comply with the regulations in force in the respective country.
- The rear of appliance is accessible so that you can connect the appliance to the drinking water supply.
- Do not damage or kink the hose during installation.

14 Connecting the water supply

Connecting the hose to the appliance

The solenoid valve is at the bottom on the back of the appliance. It has a R3/4 connecting thread.

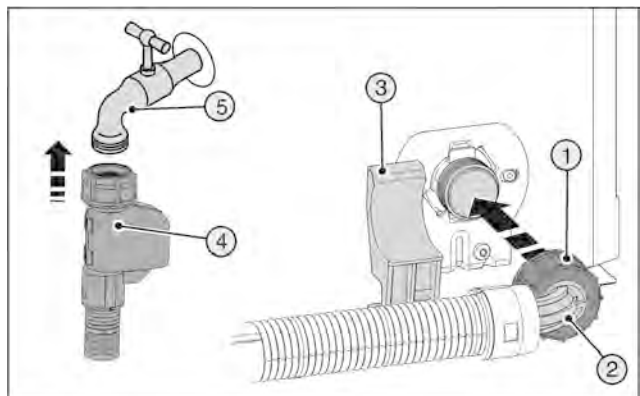

Fig. 22

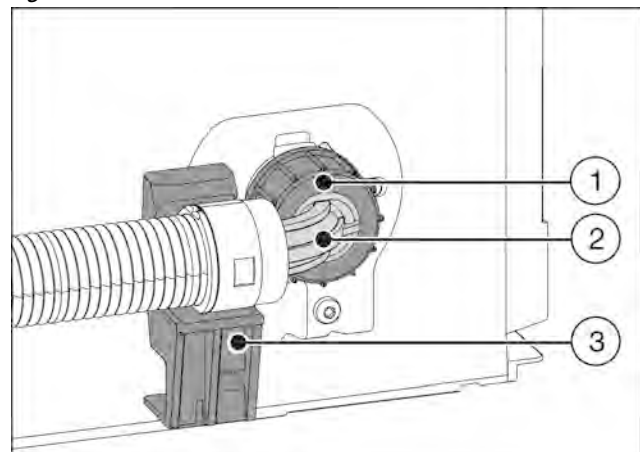

Fig. 23

- ▶ Hold the angled hose end Fig. 23 (2) horizontally at bracket Fig. 23 (3) and secure it.
- ▶ Screw the nut Fig. 23 (1) on by hand until it is firmly in place.

Connecting the hose to the stopcock

- ▶ Connect the straight end of the hose Fig. 22 (4) to the stopcock Fig. 22 (5).

Check the water system

- ▶ Slowly open the stopcock.
Before putting into its final position:
- ▶ Check the entire water system for tightness.
After installing in the recess:
- ▶ Clean the IceMaker (see User Guide, Maintenance).

Air the water system

Airing is required in the following cases:

- Initial operation
- Replacement of the InfinitySpring water tank

Ensure that the following conditions are met:

- Appliance is properly installed and connected.

Installing the appliance in the recess

- Water tank is inserted (see Operating instructions, Maintenance).
- Water filter is inserted (see Operating instructions, Maintenance).
- Appliance is switched on.
- ▶ Open the appliance door.
- ▶ Press your drinking glass or cup against the lower part of the InfinitySpring dispenser.
- ▷ The top part moves out and air or water pours into the glass.
- ▶ Continue until the water flows evenly into the glass.
- ▷ There is no more air in the system.
- ▶ InfinitySpring Cleaning (see the User Guide, Maintenance).

15 Installing the appliance in the recess

Tool



Supplied assembly parts

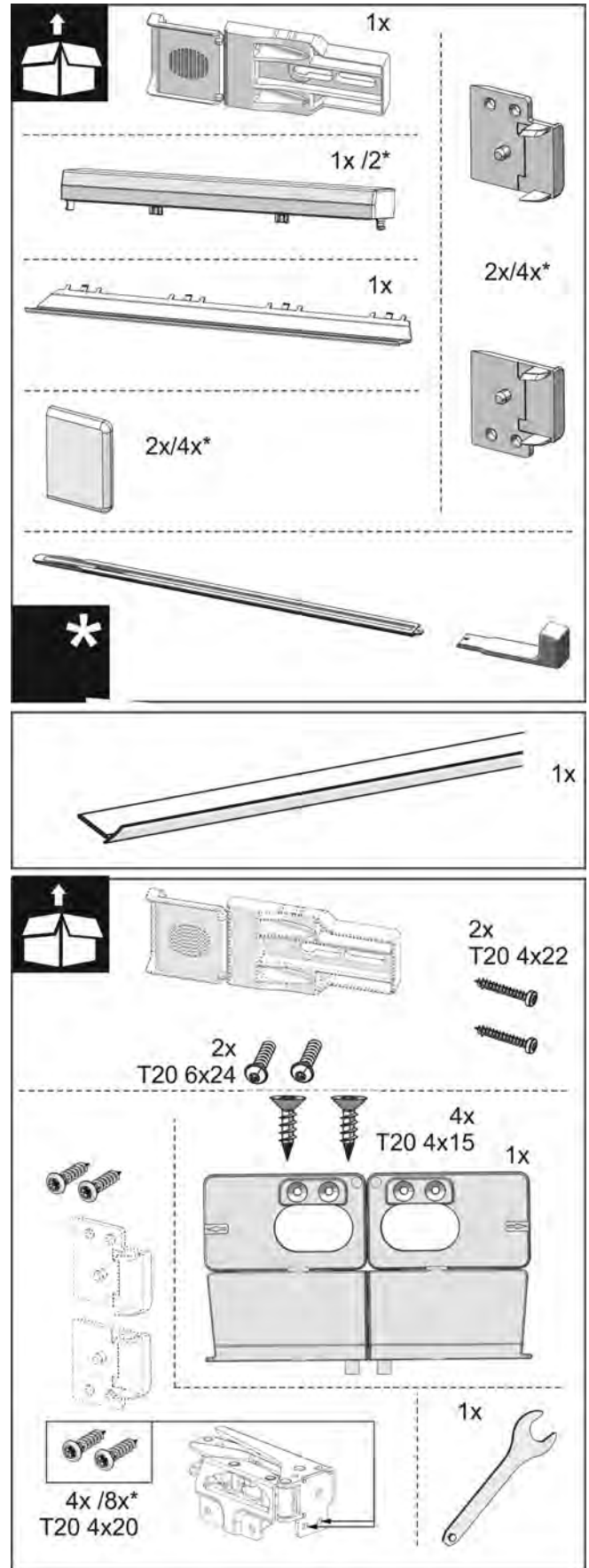

Fig. 24

Fig. 25

Installing the appliance in the recess

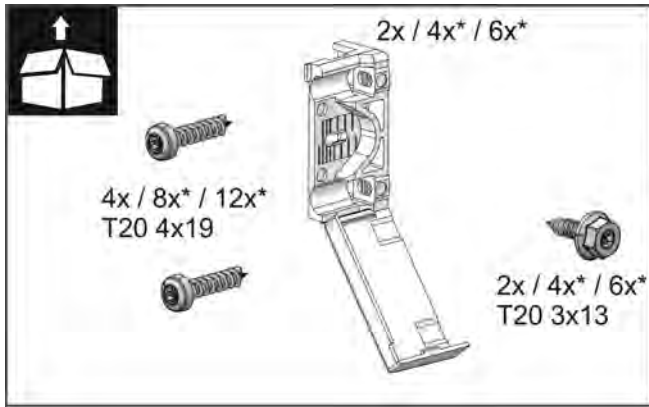

Fig. 26

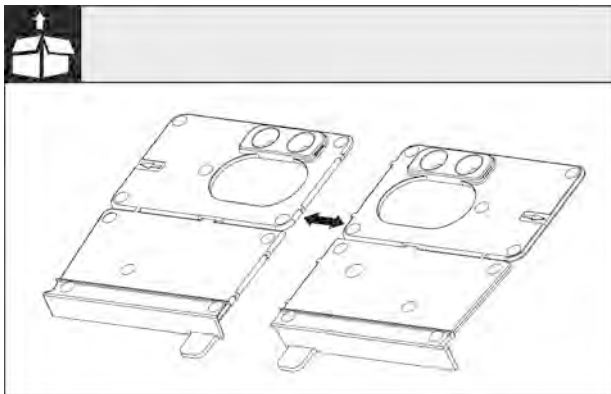

Fig. 27 Floor mounting bracket

- ▶ Separate the floor mounting bracket Fig. 27 () at the perforation.

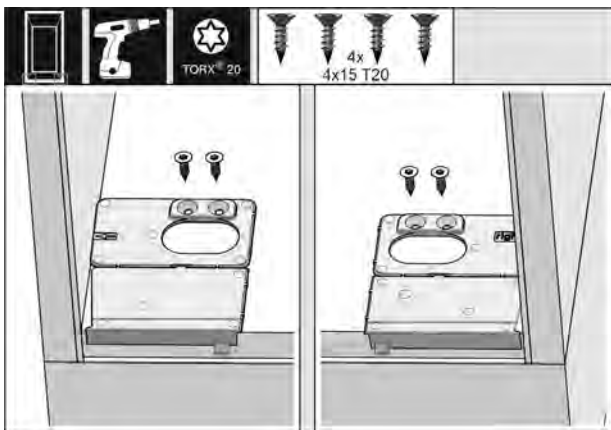

Fig. 28

NOTICE

Correct installation depth of the appliance.

- ▶ Using the mounting bracket ensures the correct installation depth of the appliance.
- ▶ Screw the mounting brackets on the left and right of the recess floor, flush to the side wall.

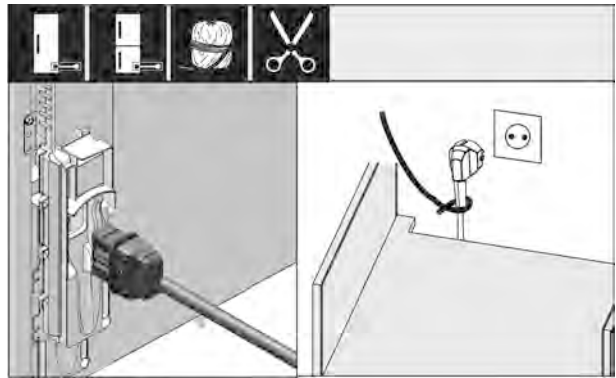

Fig. 29*

- ▶ Remove the power cable from the package and plug it into the back of the appliance. Use a cable lug to lay the power plug cord to the accessible socket.

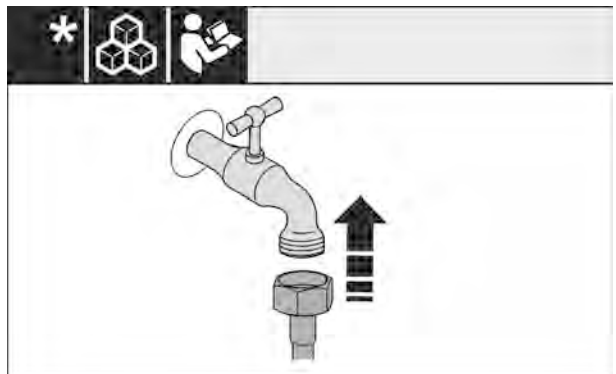

Fig. 30

- ▶ If necessary, install the water connection at this point, following the instructions in the User Guide.

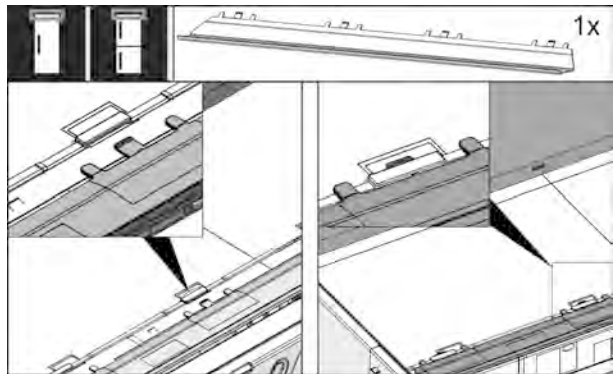

Fig. 31

- ▶ Insert the adapter panel on the top of the appliance. The panel can be moved to both sides.

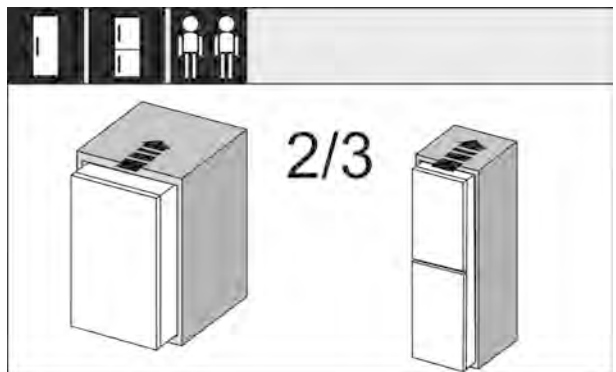

Fig. 32

- ▶ Insert the appliance 2/3 of the way into the recess.

Installing the appliance in the recess

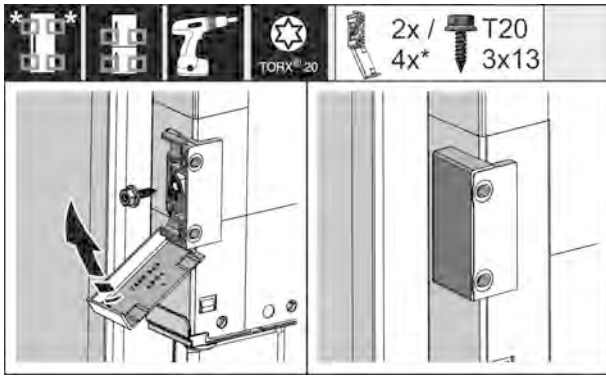

Fig. 33*

- ▶ Assemble the mounting bracket. Attach the mounting brackets to align with the cabinet door handles. If the door is large use four mounting brackets in total. After assembly, fold the covers onto the bracket.

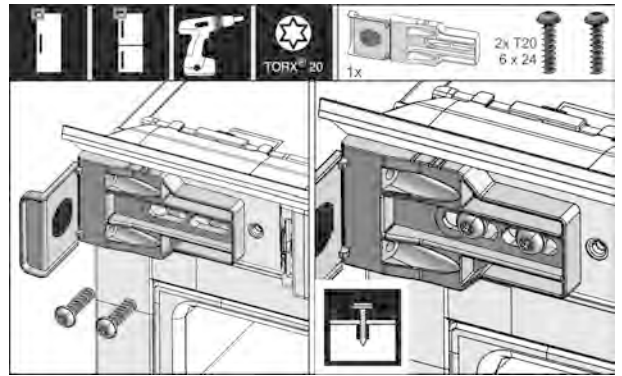

Fig. 37

- ▶ Loosely tighten the mounting bracket screw. The bracket should still be easy to move.

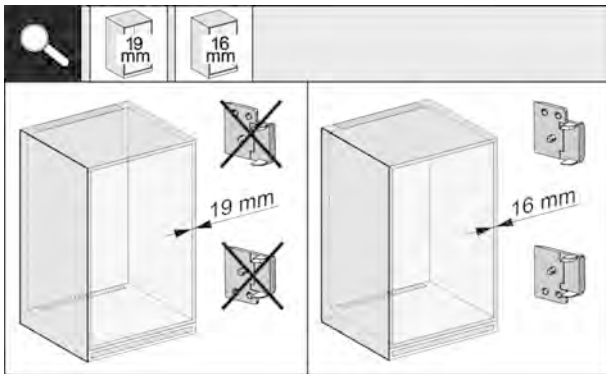

Fig. 34*

- ▶ Check whether the unit side wall is 16 mm or 19 mm thick.

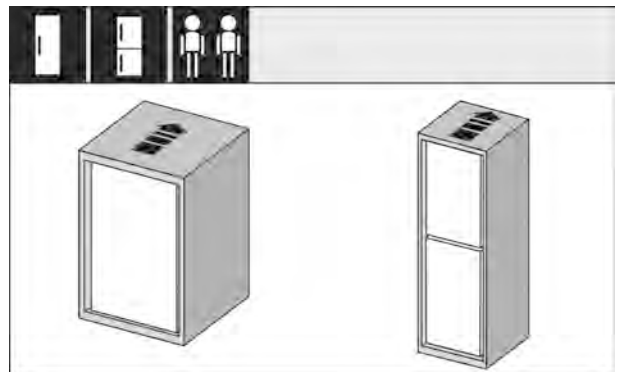

Fig. 38

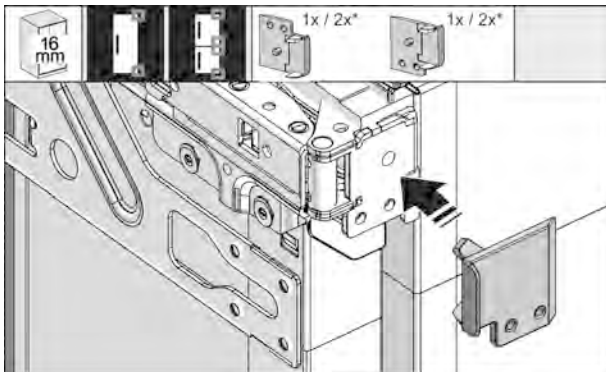

Fig. 35

- ▶ For unit walls which are 16 mm thick: Clip a spacer on all hinges. No spacer is required if unit walls are 19 mm thick.

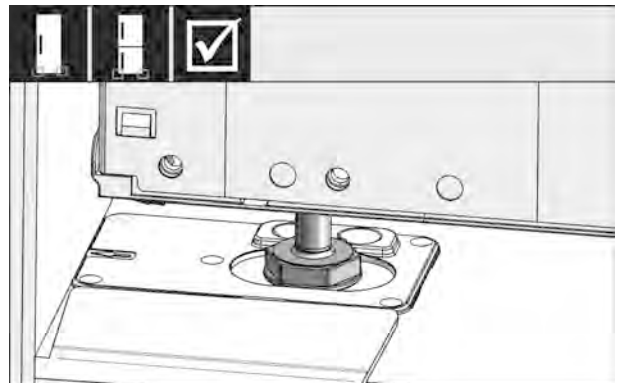

Fig. 39

- ▶ Insert the appliance all the way into the unit recess. The adjustable feet must rest in the recesses in the brackets on both sides.

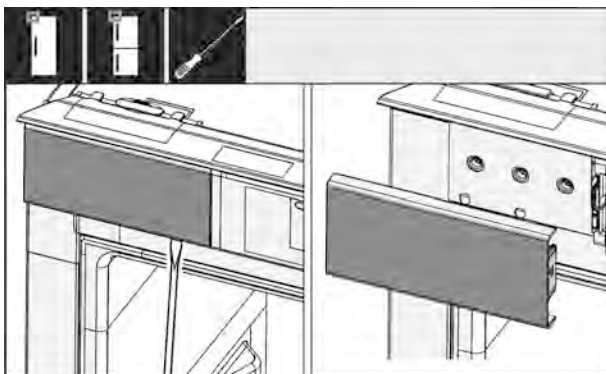

Fig. 36

- ▶ Use a screwdriver to loosen the cover at the top left and remove it.

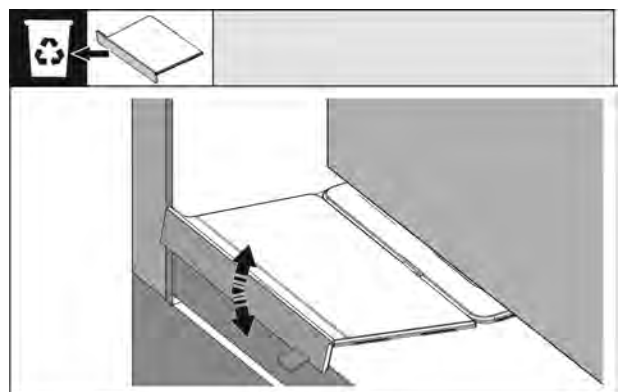

Fig. 40

- ▶ Remove the floor mounting bracket stopper. Loosen the stopper by moving it and, if necessary, pull it off using pliers.

Installing the appliance in the recess

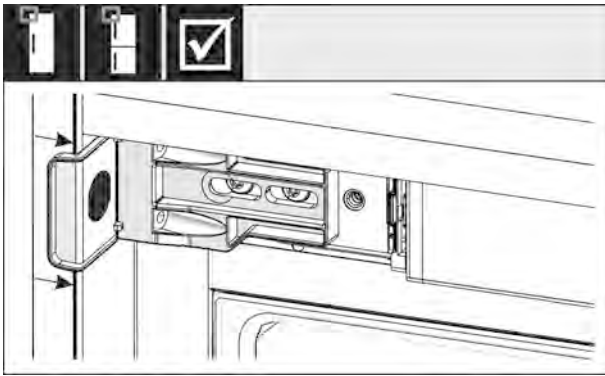

Fig. 41

- ▶ Check that the appliance is flush against the cabinet recess. The mounting bracket must be attached to the side wall of the cabinet recess.

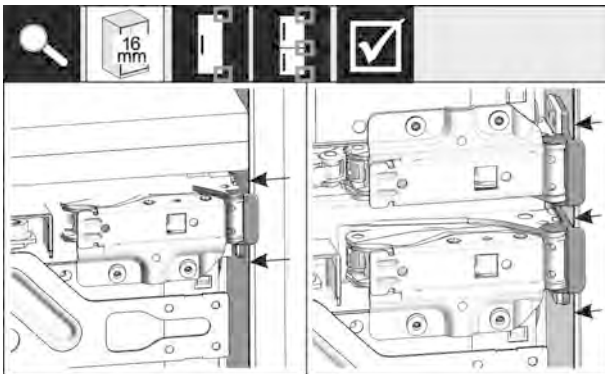

Fig. 42*

- ▶ For unit side walls which are 16 mm thick, the spacers fit against the unit recess on the hinge side.

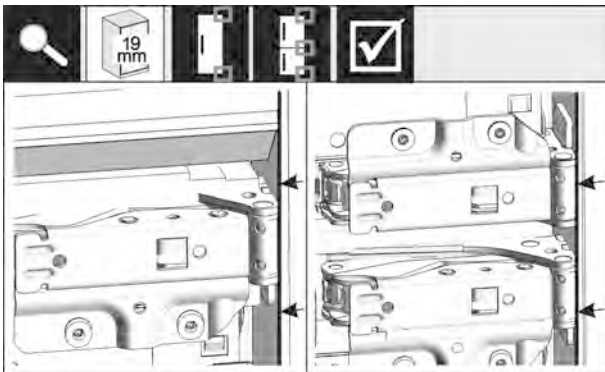

Fig. 43*

- ▶ For unit side walls which are 19 mm thick, the front sides of the hinges are positioned flush against the front of the unit side wall.

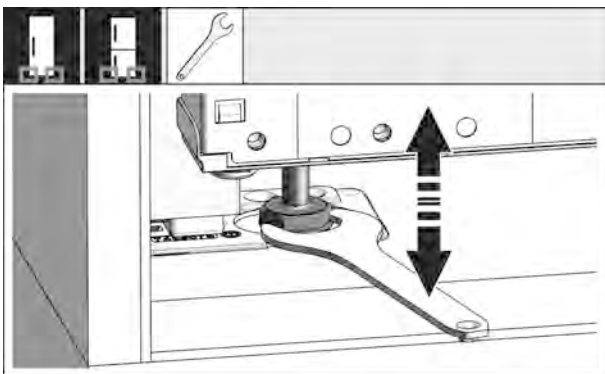

Fig. 44

- ▶ If necessary, use the adjustable feet to correct the tilt of the appliance.

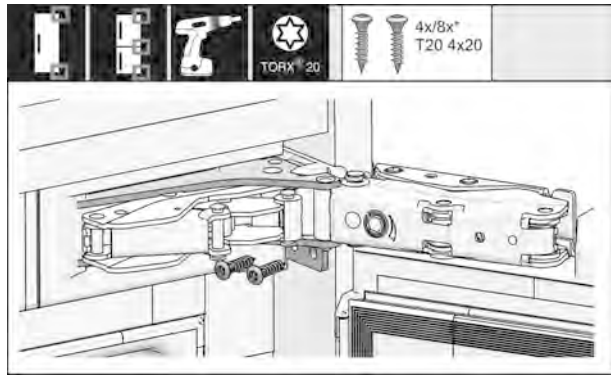

Fig. 45

- ▶ Screw on the appliance on the hinge side.

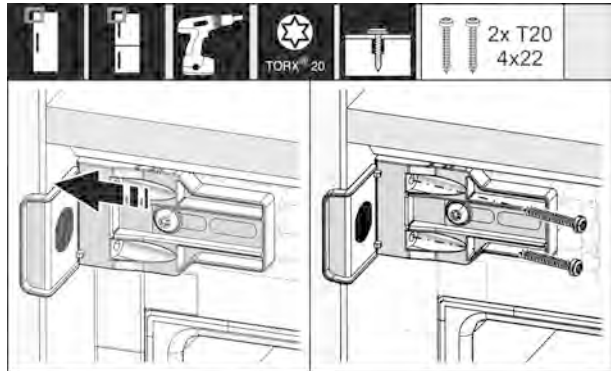

Fig. 46

- ▶ Move the bracket so it sits flush on the side wall of the cabinet recess. Tighten all screws securely.

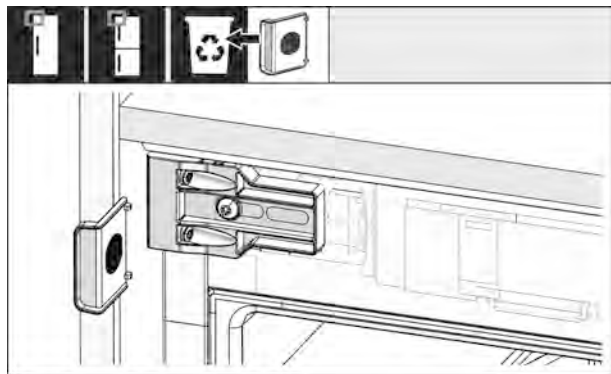

Fig. 47

- ▶ Remove the stop from the bracket on the handle side and dispose of it.

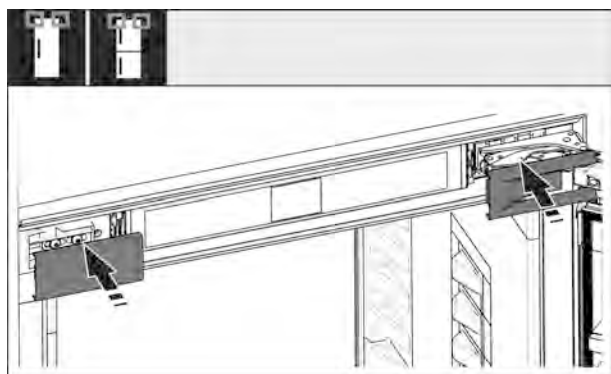

Fig. 48

- ▶ Put covers into position.

Installing the appliance in the recess

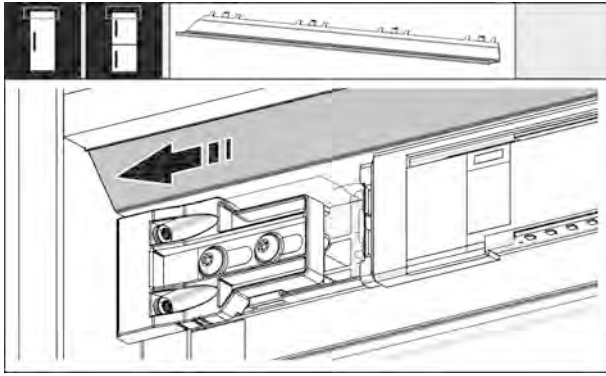

Fig. 49

- ▶ Slide the panel so that it sits flush on the side of the cabinet wall.

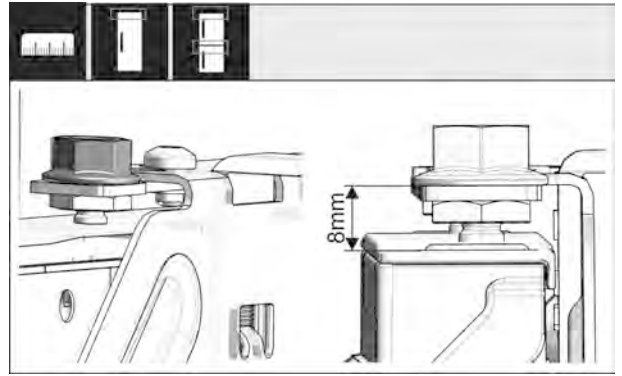

Fig. 52*

- ▶ Close the door and check the preset of 8 mm from the upper edge of the appliance door to the crosspiece support

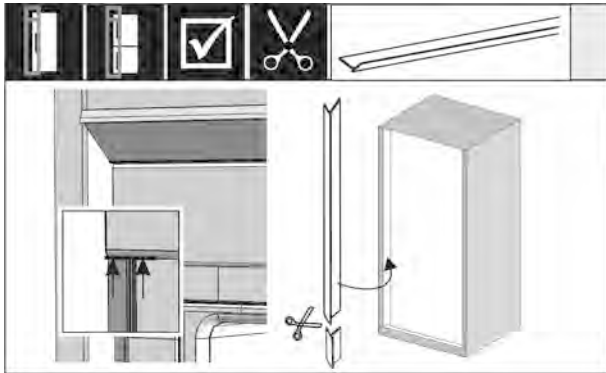

Fig. 50*

- ▶ The trim is magnetic. Place the trim below the top cover and press. If necessary, shorten the trim to the required length with a sharp pair of scissors.

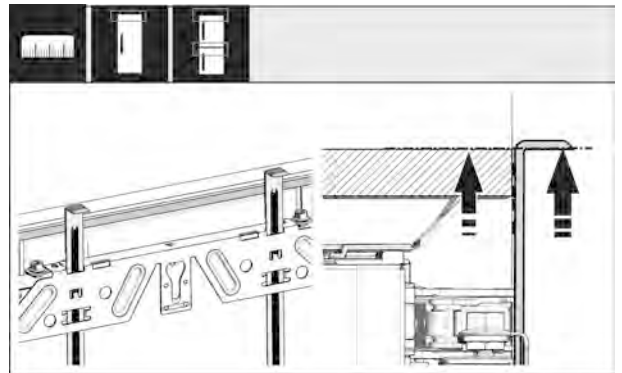

Fig. 53

- ▶ Push the assembly aids to the unit door height. Lower stop edge of the assembly aid = upper edge of the door to be assembled.

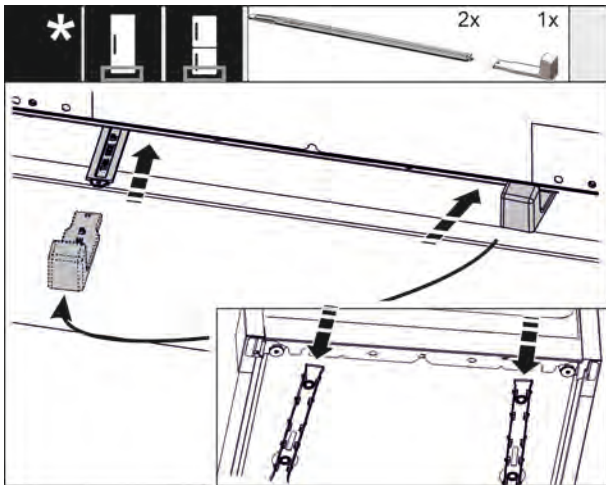

Fig. 51

The height adjustment is only supplied as standard for recess heights of 140 cm and above. It is used for sound optimisation. Both parts of the height adjustment are included in the accessory kit.

- ▶ To stabilise the appliance at the back underneath: Fit the handle onto the rail of the height adjustment and push the rail into the appliance base. Remove the handle and do the same with the second rail.

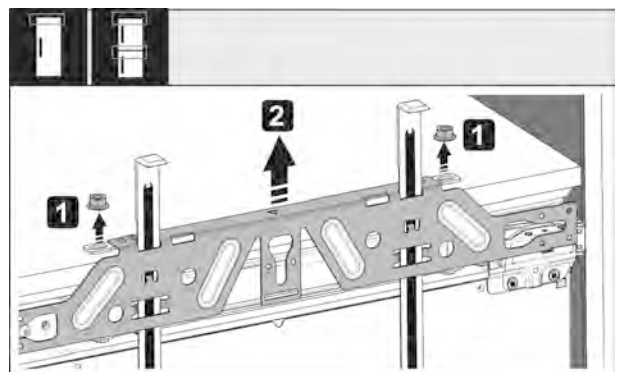

Fig. 54

- ▶ Loosen the counter nut and remove the crosspiece.

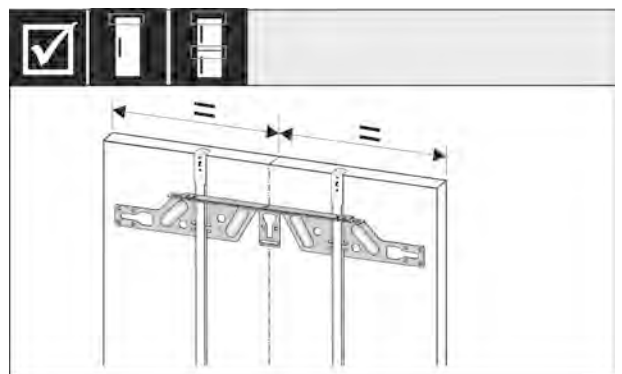

Fig. 55

- ▶ Hang the crosspiece on the inside of the unit door and make sure it is central.

Installing the appliance in the recess

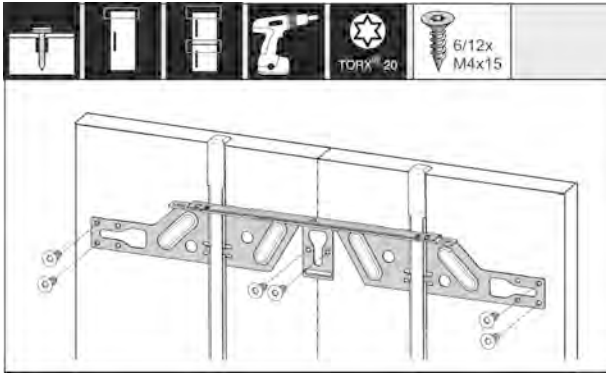

Fig. 56

- Fix the crosspiece using at least 6 screws for chipboard doors and at least 4 screws for panel doors.

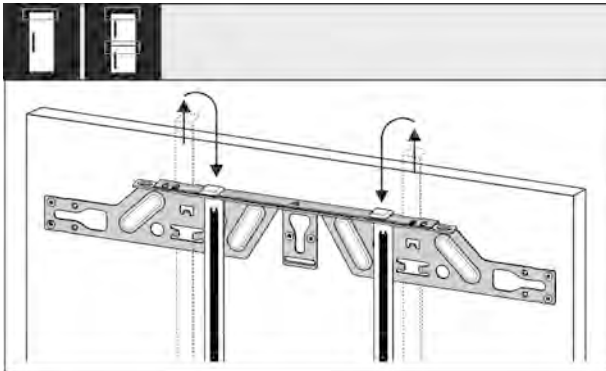

Fig. 57

- Remove the fitting aids, turn round and insert into the adjacent opening.

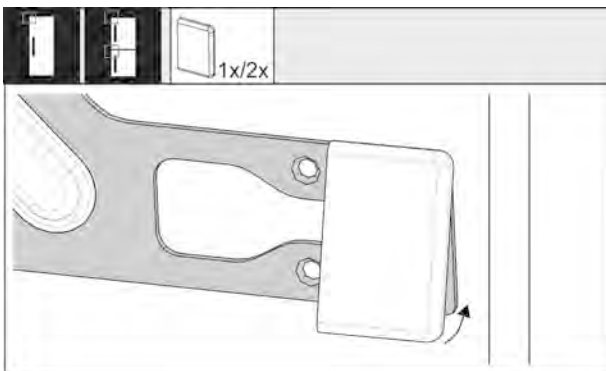

Fig. 58

- Clip the cover on the crosspiece on the handle side.

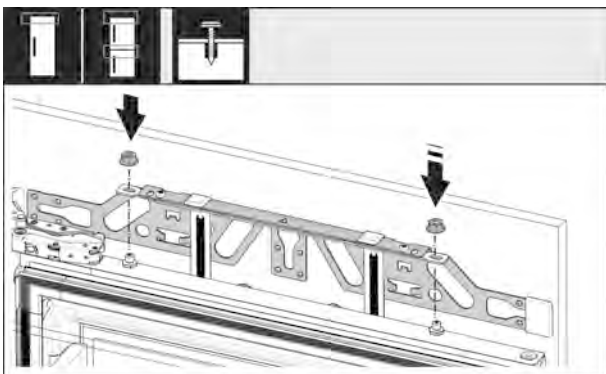

Fig. 59

- Attach the unit door and loosely screw the lock nuts onto the adjusting bolts.

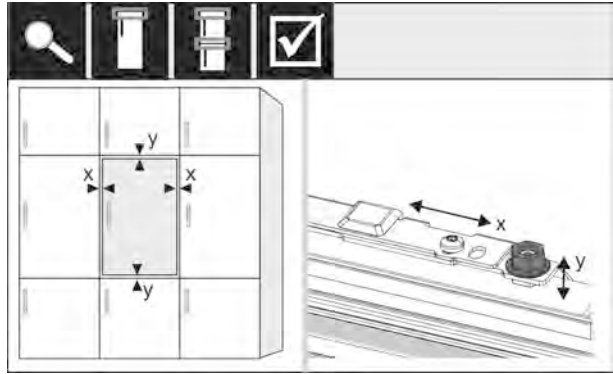

Fig. 60

- Align the unit door in the X and Y direction using the adjusting bolts.

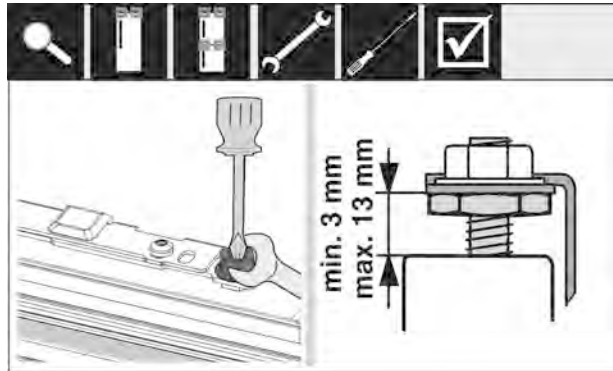

Fig. 61*

- Screw on the lock nuts and check the height.

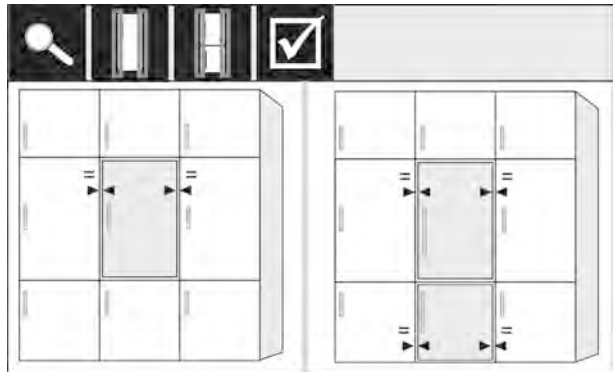

Fig. 62

- Check the gap between the door and the surrounding custom panels. For unit fronts thicker than 19 mm, take account of the dimensions and advice in the chapter **Unit fronts**.

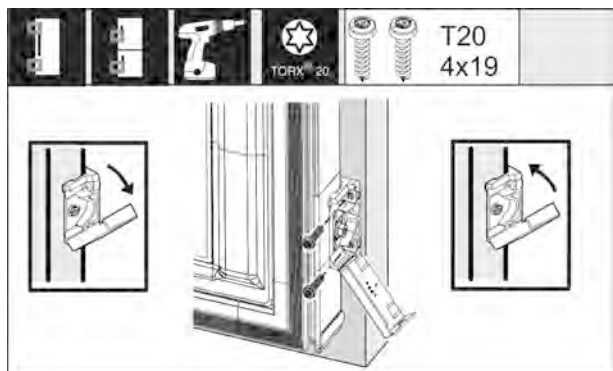

Fig. 63*

Cabinet fronts

- ▶ Open the cover to fit the mounting bracket on the custom panel. Align the front edge of the mounting bracket parallel with the custom panel edge and screw the bracket down tightly. Fold up the cover.

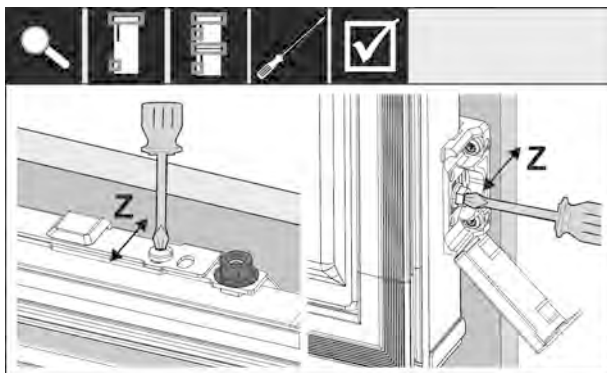

Fig. 64

Align the custom panel in the Z direction:

- ▶ Loosen the adjusting screw on the crosspiece and the screw on the mounting bracket.
- ▶ Move the door.

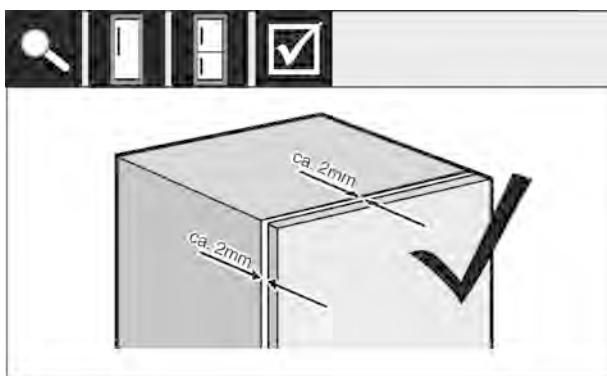

Fig. 65*

- ▶ Check the gap between the custom panel and the unit body.
- ▶ Check all screws and retighten them if necessary.

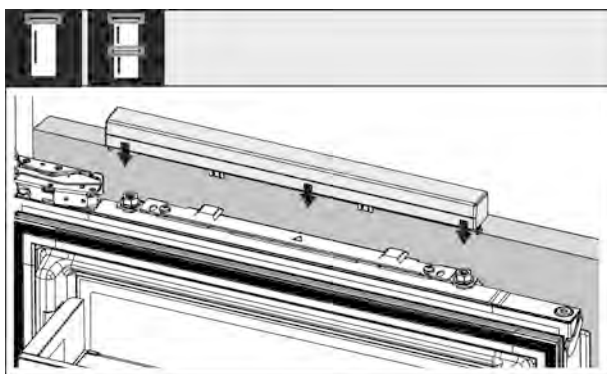

Fig. 66

- ▶ Clip the top cover on.

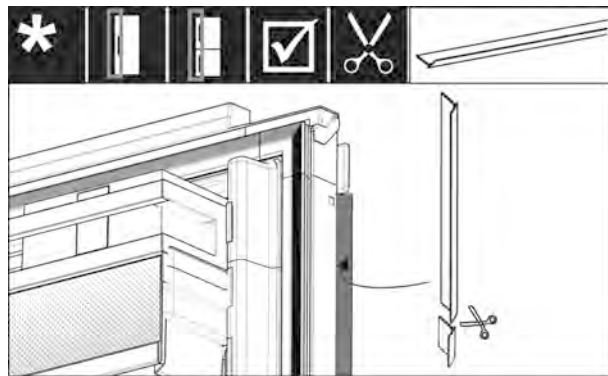

Fig. 67

- ▶ Adjust the tread, cut it to length and place it between the cabinet door and the appliance door.

Check the following points to ensure the appliance is correctly installed. Otherwise, ice and condensation may form, and malfunctions may occur:

- ▷ The door must close properly.
- ▷ The unit door must not touch the body of the unit.
- ▷ The seal on the upper corner on the handle side must be fitted securely.

16 Cabinet fronts

16.1 Dimensions

Depending on your model, you will need one or two cabinet doors. The size of the cabinet door(s) depends on the overall recess size and cabinet unit thickness.

Note

Observe the appliance and recess dimensions and follow the installation diagrams (see 3 Appliance dimensions) (see 4 Recess dimensions) . See the relevant catalogue for the installation diagrams.

General requirements:

- Please refer to our catalogues for appliance-specific recommendations on size and weight for fixed door installations.
- The cabinet unit thickness should be at least 16 mm and no bigger than 19 mm.
- When mounting a 2-door cabinet door, observe the recommended clearances.

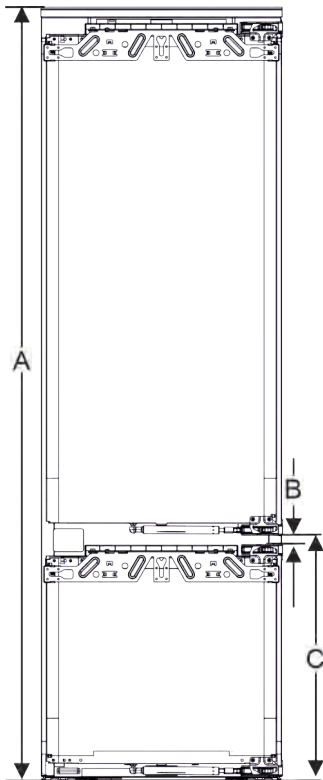

Fig. 68 Clearances for a 2-door cabinet door

Recess height*	Appliance height (mm)*	Distance (B) (mm)*	Clearance (C) fixed door (mm)*
178-2 drawers*	1770	15	549+15
178-3 drawers*	1770	15	695+15

Other cabinet door above, below or next to it:

- Vertical gap between cabinet doors must be 4 mm.
- Horizontal gap between cabinet doors must be 4 mm. Check the collision factors here (see 16.3 Setting the clearance to avoid collision).

Weight and hinges:

- Heavy cabinet fronts increase the stress on the hinge. The hinge may be damaged. As such, refer to the catalogue for the maximum weight specification for your appliance.
- If the cabinet front exceeds the maximum permitted weight, an appliance with door-tracking device can help by loading the weight over several concealed hinges on the cabinet.
- If you have long cabinet fronts that protrude a long way above the appliance, we recommend an additional door hinge (e.g. Kamat), which by design has the same pivot point as the fixed door hinge used by Liebherr appliances. Using an additional hinge (Kamat) loads the weight over multiple points. We recommend using a milled adapter fitting for high cabinet fronts to counteract any dragging (convex/concave).

16.2 Mounting the cabinet front(s)

When installing, note:

- Cabinet front must be installed symmetrically to the refrigerator door.
- Adjoining cabinet front is exactly level.
- Adjoining cabinet front has the same edge radius as the front of the appliance.

- Cabinet front is flat and tension-free.
- Cabinet front is adjusted to a minimum depth of approx. 2 mm to the unit body.
- ▶ Fit the appliance into the recess (see 15 Installing the appliance in the recess).
- ▶ Attach the cabinet front to the appliance door (see 15 Installing the appliance in the recess).
- ▶ Check the cabinet front does not collide with anything (see 16.3 Setting the clearance to avoid collision).

16.3 Setting the clearance to avoid collision

After installing the cabinet front(s), check that the cabinet fronts do not collide.

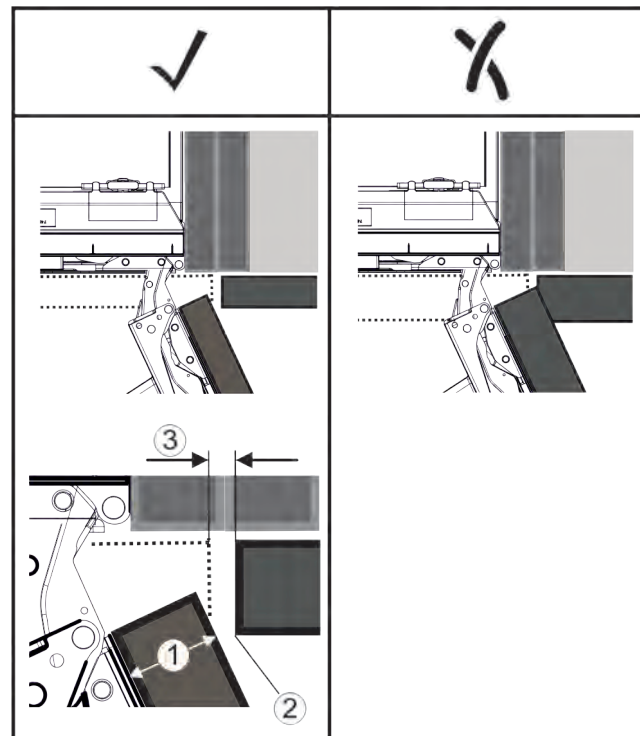

Fig. 69

- (1) Front thickness (FD) (3) Clearance (S)
(2) Edge radius (R)

FD(1) (mm)	R (2) = 0 mm		R = 1,2 mm		R = 2 mm		R = 3 mm	
	G _{min}	G _{max}	G _{min}	G _{max}	G _{min}	G _{max}	G _{min}	G _{max}
16	0,3	0,9	0,1	0,4	0,1	0,2	0,1	0,2
19	0,7	2,4	0,3	1,9	0,23	3,25	0,1	0,8
20	2	4,3	1,5	3,6	1	3,1	0,6	2,7
22	3,5	6,3	3	5,6	2,6	5,3	2,1	4,6
24	5,5	8,3	5	7,8	4,5	7,4	4	6,9
26	7,6	10,7	7	10,3	6,6	9,9	6,2	9,4

Fig. 70 Table of clearance limits*

G_{min} = min. clearance in mm*

G_{max} = max. clearance in mm*

Note

When making adjustments, always make sure that the cabinet front suits the general appearance.

Check the collision factors and adjust them accordingly:

- ▶ Determine the front thickness and edge radius.
- ▶ Refer to the table for the min./max. clearance dimensions.
- ▶ Check the clearance size against the table.
- ▶ Do one of the following depending on the measured clearance size.

Water tank

Clearance	Description
$S > G_{\max}$	If the clearance size is greater than the two limits, you do not need to make any adjustments.
$S < G_{\min}$	If the clearance size is below the limits, you must increase it. Another option is to increase the edge radius.
$G_{\min} \leq S \leq G_{\max}$	If the clearance is between the two limits, you have to be careful. This will quickly lead to collisions.

17 Water tank

Depending on your model, the InfinitySpring water tank is behind the lowest drawer in the fridge or BioFresh compartment

17.1 Inserting the water tank

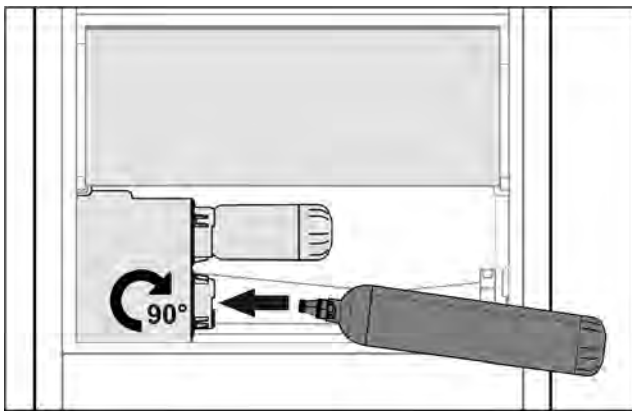

Fig. 71

- ▶ Remove the drawer compartment.
- ▶ Insert the water tank and rotate approx. 90° clockwise until it clicks in.
- ▶ Check that the tank is sealed and no water leaks out.
- ▶ Insert the drawer compartment.
- ▶ Vent the water system (see the Installation Instructions, Water Connection)

Instead of the water filter you can insert an additional water tank.

Note

You can purchase this water tank as an optional extra.

Note

Only use the power connection lead supplied.

- ▶ A longer power connection lead can be ordered from Customer Service.

Ensure that the following conditions are met:

- The type of current and voltage at the installation site complies with the information on the type plate .
- The socket is earthed according to the regulations and fused.
- The fuse tripping current is between 10 and 16 A.
- The socket is easily accessible.
- The socket is outside the back of the appliance area in the specified area (*a, b, c*).
- ▶ Check the electrical connection.
- ▶ Insert the appliance plug (*G*) into the back of the appliance. Ensure that it clicks into place.
- ▶ Connect the power plug to the power supply.
- ▷ The Liebherr logo appears on the screen.
- ▷ The display switches to the standby symbol.

18 Connecting the appliance



WARNING

Failure to connect properly
Fire hazard.

- ▶ Do not use an extension cable.
- ▶ Do not use distributor blocks.

NOTICE

Failure to connect properly
Damage to the electronics.

- ▶ Do not use a standalone inverter.
- ▶ Do not use an energy saving plug.



home.liebherr.com/fridge-manuals

EN built-in fridges and freezers, fixed door

Issue date: 20220112
Part number index: 7088287-00