

Operating instructions

Chest freezer

Read the operating instruction before switching on for the first time

Page 9

EN

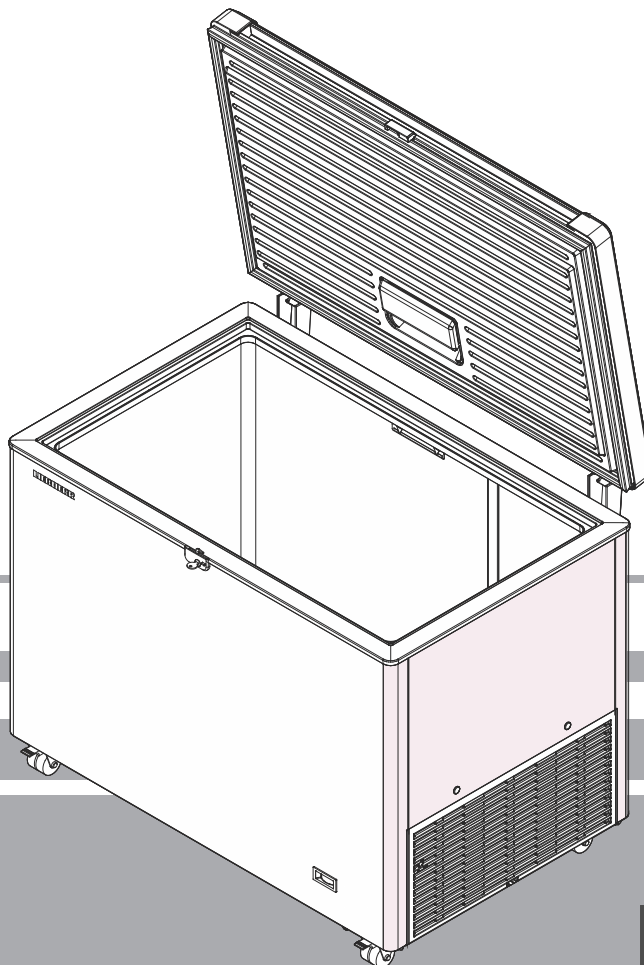



7084 975-00

EFL

LIEBHERR

Priority of warnings

 DANGER	identifies a situation involving direct danger which, if not obviated, may result in death or severe bodily injury.
 WARNING	identifies a dangerous situation which, if not obviated, may result in death or severe bodily injury.
 CAUTION	identifies a dangerous situation which, if not obviated, may result in minor or medium bodily injury.
NOTICE	identifies a dangerous situation which, if not obviated, may result in damage to property.
Note	identifies useful information and tips.

Safety instructions and warnings

- **WARNING:** Keep ventilation openings, in the appliance enclosure or the built-in structure, clear of obstruction.
- **WARNING:** Only use the mechanical devices or other aids recommended by the manufacturer to help speed up the defrosting process.
- **WARNING:** Do not damage the refrigerant circuit.
- **WARNING:** Do not use any electrical devices in the refrigerator compartment which do not comply with the design recommended by the manufacturer.
- **WARNING:** The main cable must not be damaged while installing the appliance.
- **WARNING:** Multi-sockets or distributor strips and other electronic devices (such as halogen transformers) must not be positioned and operated at the rear of appliances.
- **WARNING:** Danger of injury through electric shock. There are live parts under the cover. Only have the interior LED light replaced or repaired by customer service staff or trained personnel.
- **WARNING:** Risk of injury from the LED lamp. The light intensity of the LED light complies with laser class RG 2. If the cover is defective, do not look directly at the light through optical lenses from a close distance. This may damage your eyes.
- **WARNING:** When positioning the appliance, ensure the supply cord is not trapped or damaged.
- **WARNING:** Do not locate multiple portable socket-outlets or portable power supplies at the rear of the appliance
- **WARNING:** This appliance must be secured as described in the operating instructions (Installation instructions) to rule out any potential risks due to its instability.
- This appliance may be used by children aged 8 and over and by people with reduced physical, sensory or mental abilities or a lack of experience and expertise if they are supervised or have been instructed on the safe use of the appliance and have understood the risks associated with it. Children must not be allowed to play with the appliance. Cleaning and user maintenance must not be carried out by children without supervision. Children aged 3 or over and 8 or younger may load and unload the refrigerator/freezer.
- Do not store any explosive substances, such as aerosol containers with flammable propellant gas, inside the appliance.
- To prevent injury and damage to property, the appliance should only be installed by two people.
- After unpacking it, check the appliance for signs of damage. Contact the supplier if it is damaged. Do not connect the appliance to the mains power supply.
- Avoid prolonged skin contact with cold surfaces (e.g. chilled/frozen products). If necessary, take safety action (e.g. gloves).
- Do not eat ice cream, particularly ice lollies or ice cubes, immediately after taking them from the freezer compartment as there is a risk of "burning" because of the very cold temperatures.
- Do not consume food which has been stored for too long, as it could cause food poisoning.
- All repairs and work on the appliance may only be carried out by customer service personnel or other trained personnel. The same applies to changing the mains power cable.
- Only carry out repair and other work on the appliance when the mains plug has visibly been disconnected.
- Only install, connect and dispose of the appliance as described in these operating instructions.
- In the event of a fault, pull out the plug or switch off the fuse.
- When disconnecting the appliance from the mains, pull on the plug. Do not pull on the cable.

EN

- If you have a lockable appliance, do not keep the key near the appliance or within reach of children.
- The appliance is designed for use in enclosed areas. Do not operate the appliance outdoors or in areas where it is exposed to splash water or damp conditions.
- Do not use the interior LED light to light the room. The interior LED light is only designed to illuminate the interior of the appliance.
- Do not allow naked flames or ignition sources to enter the appliance.
- Alcoholic drinks or other vessels containing alcohol should be sealed tightly for storage.

Disposal notes

The appliance contains reusable materials and should be disposed of properly - not simply with unsorted household refuse. Appliances that are no longer needed must be disposed of professionally and appropriately, in accordance with the current local regulations and laws.



When disposing of the appliance, ensure that the refrigerant circuit is not damaged to prevent the uncontrolled escape of the refrigerant it contains (data on type plate) and oil.

- Disable the appliance.
- Pull out the mains plug.
- Cut through the connection cable.

⚠ WARNING

Danger of suffocation due to the packing material and plastic film! Do not allow children to play with packaging material. Take the packaging material to an official collection point.

Symbols on the appliance

	The symbol can be located on the compressor. It refers to the oil in the compressor and indicates the following danger: swallowing or inhaling can be fatal. This is only relevant for recycling. There is no danger in normal operation.
	Risk of fire / flammable materials
	A sticker to this effect may be applied to the rear of the appliance. It refers to the foampadded panels in the door and/or the housing. This is only relevant for recycling. Do not remove the sticker.

Range of appliance use

The appliance is suitable solely for storage and freezing packed foods in a domestic environment or similar. This includes, for example, the use

- in staff kitchenettes, bed and breakfast establishments,
- by guests in cottages, hotels, motels, and other forms of accommodation,
- in catering and similar services in the wholesale trade.

Use the appliance solely as is customary within a domestic environment. All other types of use are inadmissible. The appliance is not suitable for storing and cooling medicines, blood plasma, laboratory preparations, or similar substances and products covered by the 2007/47/EC Medical Devices Directive. Any misuse of the appliance may result in damage to or spoilage of stored goods. Furthermore, the appliance is not suitable for operation in potentially explosive atmospheres.

Climate rating

The climate rating indicates the room temperature at which the appliance may be operated in order to achieve full refrigeration performance.

The climate rating is indicated on the type plate.

The position of the type plate is shown in the section entitled **Description of the appliance**.

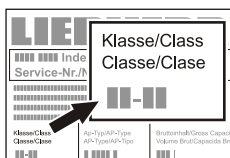

[X] Climate rating	Max. room temperature	Max. relative humidity
3	25°C	60%
4	30°C	55%
5	40°C	40%
7	35°C	75%

The minimum room temperature at the place of installation is 10°C.

Description of the appliance

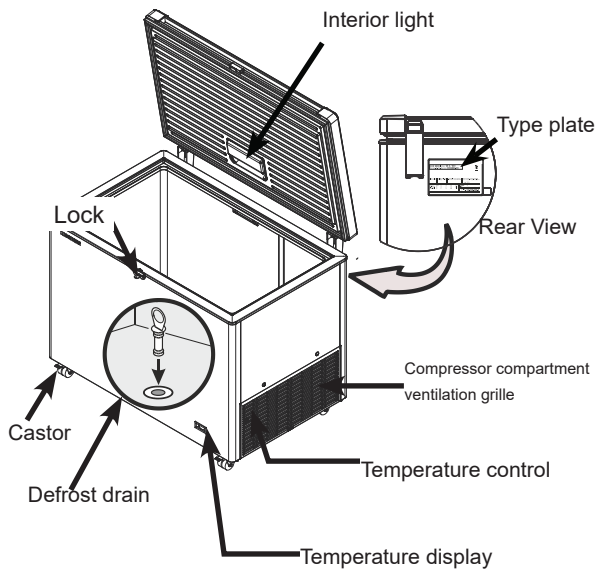

Appliance dimensions

Model	A	B	C
EFL 3055 / 3056	825	1045	720
EFL 4655 / 4656	825	1465	720
EFL 6055 / 6056	825	1885	720

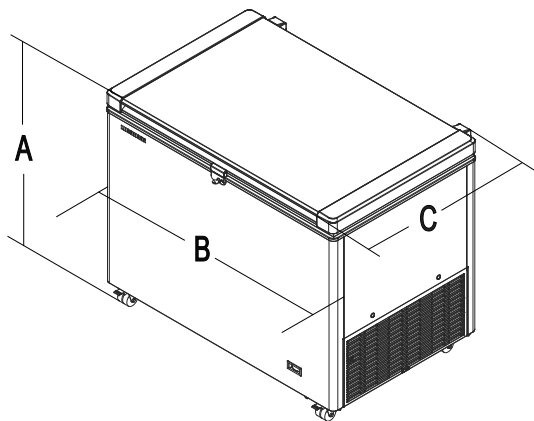

Installing the appliance

! DANGER!	Unsuitable ratio of refrigerant to installation room volume. Risk of explosion.
	▶ Ensure that the room which you install your appliance has a volume of 1 m ³ per 8 g of R600a/R290 refrigerant used in the appliance as set out in standard EN 378.

Requirements for the place of installation:

Check that the volume of the installation room is large enough relative to the appliance's refrigerant capacity.

The refrigerant capacity is shown on the type plate.

- No direct sunlight.
- No heat sources such as a stove or heater in the vicinity.
- The floor is horizontal and flat.

① The ventilation clearance between the edge of the chest and the floor is used to supply the refrigeration unit with cooling air.

➡ Ensure that the ventilation clearance between the underside of the chest and floor is not blocked.

➡ Ensure the distance between the ventilation grille and wall is at least 50 mm.

➡ Ensure that the area between the ventilation grille and wall is not obstructed.

➡ Ensure that the ventilation grille is clear of dirt and foreign bodies.

① The appliance dissipates air through its exterior skin.

➡ Do not place objects right next to the exterior skin of the appliance.

➡ Ensure that the distance between the exterior skin of the appliance and neighbouring items is at least 20 mm.

➡ After the machinery installed, it maintains its hygienic integrity and there is adequate access for servicing and cleaning.

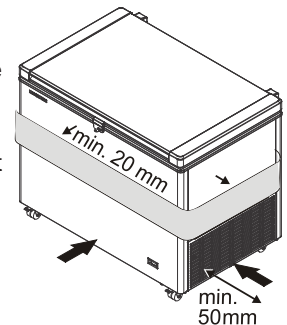

Transportation and handling

➡ For the safety reason, move the unit which equipped with the roller.

➡ Lift the appliances carefully. Never use the door handle for lifting.

➡ This unit is heavy and could injury. Please ensure there is sufficient person power during lift the appliance.

Electrical connection

⚠ DANGER!	Incorrect voltage supply. Damage to property or personal injury.
	▶ Ensure that the voltage supply complies with the specifications in the section entitled "Technical data".

➡ Ensure that the socket is not covered by the appliance and is easily accessible.

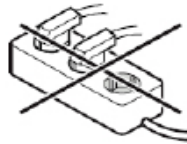

- ➡ Power supply (AC) and voltage at the operating point must comply with the details on the type plate. The type plate is located on the rear of the appliance.
- ➡ Only connect the appliance to a socket protected by a fuse which has been earthed in accordance with the appropriate regulations.
- ➡ The socket must be fused with a 10 A fuse or higher, it must be away from the rear of the appliance and must be easily accessible.
- ➡ Do not connect the appliance using extension cables or extension sockets.

Connect the appliance with a properly earthed fused plug and socket only.

Accessories

Lock for EFL

The lock is equipped with a safety mechanism.

Locking the appliance:

1. Press the button and keep it depressed.
2. Turn the key 90°.

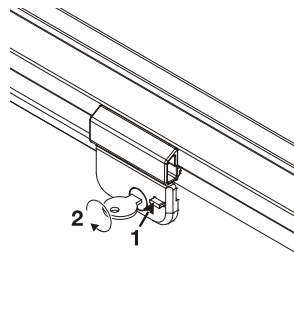

Baskets

Baskets are available as accessories.



NOTICE	Excessive load! Damage to property.
---------------	---

Model	Basket	Max load
EFL	210 mm	47 kg
	270 mm	54 kg

Commissioning

Unpacking

⚠ DANGER!	Packaging material and film. Danger of asphyxiation.
	▶ Do not allow children to play with the packaging material.

- ➡ Please take packaging to an official collection point.
- ➡ Clean the interior of the appliance before switching it on for the first time, see "Cleaning".

Equipment

Interior LED light

An LED lamp is fitted as standard to illuminate the interior of the appliance.

The interior light switches on automatically when the lid is opened and switches off again when it is closed.

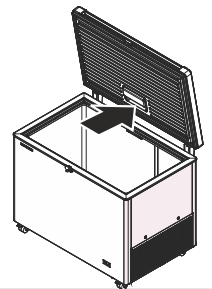

⚠ WARNING!	High light intensity. Eye injury.
	▶ Do not remove the light cover. ▶ Do not look into the light through optical lenses.

Replacing the lamp

Only original LED lamps from the appliance manufacturer may be used. The lamp can be purchased from the customer service department or specialist dealers.

⚠ WARNING!
When using LED lamps made by other manufacturers, there is a risk of overheating or fire.

Setting the temperature

The temperature can be infinitely adjusted using the control knob. There are markings near the control knob. The appliance will achieve its lowest temperature when set to 3 (***) .

- ➔ To set the temperature, turn the control knob to required setting (* to ***) using a flat-blade screwdriver.

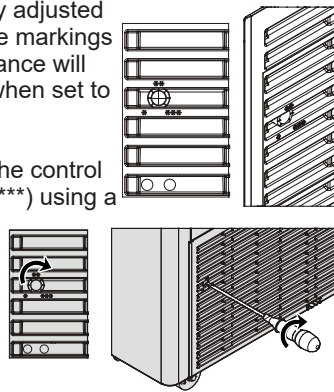

Temperature display

The thermometer shows the warmest temperature of the frozen volume at the maximum filling height.

It is adjusted and designed so that only temperatures below 0°C are accurately displayed.

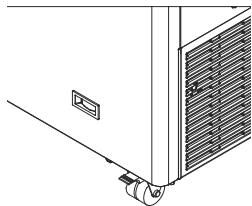

NOTICE	Incorrect room temperature. Damage to property and reduced cooling capacity.
	▶ Ensure that the room temperature corresponds to the climate rating of the appliance, see "Technical data".

Shutting down the appliance

Switching the appliance off

- ➔ Pull out the mains plug or turn the temperature control knob anti-clockwise until it locks in the Off position.
- ⓘ If it is switched off using the temperature control knob, the appliance is not disconnected from the mains supply.

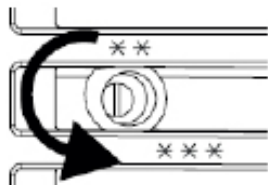

Before shutting down the appliance for a lengthy period

- ➔ Switch off the appliance.
- ➔ Pull out the plug or switch off the fuse.
- ➔ Clean the appliance.
- ➔ Ensure that the appliance is dry inside and outside.
- ⓘ **There must be no moisture in the interior container.**
- ⓘ If the chest lid is closed when the appliance remains shut down for a length period, odours will form inside it.
- ➔ Open the chest lid and secure it to prevent it being closed.
- ➔ Ensure that the ambient conditions for storage comply with the specifications in the section entitled "Storing the appliance after shutting down".

Malfunctions/Troubleshooting

- ⓘ Contact your nearest customer service department if the appliance suffers faults which you cannot rectify.
- ⓘ To ensure that your query can be dealt with quickly, make a note of the type designation 1, service number 2 and serial number 3 on the type plate and quote them when you contact the customer service department. The position of the type plate is shown in the section entitled "Description of the appliance".

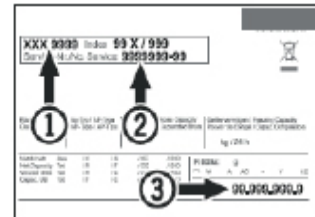

Malfunction	Possible cause	Remedy
Appliance does not cool down.	The temperature control knob is in the Off position.	Set the temperature control knob to a cooling position.
	The mains plug has been disconnected.	Connect the appliance to the mains.
	The power supply has been interrupted.	Check the power supply. Check the fuses in the power supply.
The temperature is not low enough.	Incorrect temperature set.	Set the correct temperature.
	The thermometer display is incorrect.	Check the temperature with an additional thermometer.
	Ventilation is inadequate.	Ensure that there is adequate ventilation.
	The appliance is located too close to a heat source.	Remove the heat source. Choose a suitable place of installation.

EN Defrosting

After a long period of operation, a layer of frost or ice can build up on the walls of the freezer compartment.

The layer of frost or ice will form more quickly if the appliance is opened frequently. A thick layer of ice increase energy consumption. You should therefore defrost the freezer regularly.

⚠ CAUTION!	High light intensity. Eye injury.
	<ul style="list-style-type: none"> ▶ Do not use electric heaters or steam cleaners, naked flames or defrosting sprays. ▶ Do not remove ice with sharp objects. (Risk of damage to the interior walls)

Defrosting

- ➡ Switch off the appliance.
- ➡ Pull out the plug or switch off the fuse.
- ➡ Wrap the frozen goods in paper or blankets and store in a cool place.
- ① Mop up defrost water with a sponge or cloth in appliances without a drain opening.
- ➡ Place a suitable vessel under the drain opening to collect defrost water.
- ➡ Remove the defrost water plug from the drain opening.
- ➡ Leave the lid open while defrosting.
- ➡ Mop up the remaining defrost water with a cloth after defrosting.
- ➡ Clean the appliance, see "Cleaning".

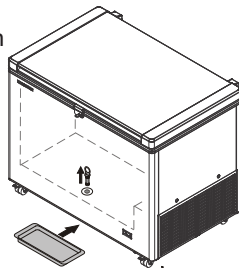

Cleaning, Hygiene and Storage food

⚠ DANGER!	Risk of electric shock if an incorrect cleaning method is used. Danger of death. ▶ Pull out the mains plug before starting the cleaning work.
------------------	--

⚠ CAUTION!	Hot steam. Injuries and damage to property. ▶ Do not use steam/high-pressure cleaning equipment.
-------------------	---

NOTICE	Unsuitable cleaning products. Damage to the appliance.
	<ul style="list-style-type: none"> ▶ Do not use concentrated cleaning products without diluting them. ▶ Only use soft cloths and an all-purpose cleaner with neutral pH value. ▶ Only use food-compatible cleaning and care products on the inside of the appliance.

① Clean the appliance every 6 month as a typical routine procedures for cleaning. Refer below steps for the cleaning.

- ➡ Remove all the frozen items.
- ➡ Place a suitable vessel under the drain opening.
- ➡ Remove the defrost water plug from the drain opening.
- ➡ Ensure that no water flows into the ventilation grille or electrical components during cleaning.
- ➡ Clean the interior container, outer walls and equipment parts of the appliance using suitable cloths and a mixture of lukewarm water and all-purpose cleaner.
- ➡ Dry the appliance with a suitable cloth.
- ① **There must be no moisture in the interior container.**
- ① Dust deposits on the ventilation grille cause increased power consumption.
- ➡ Remove dust deposits from the ventilation grille.

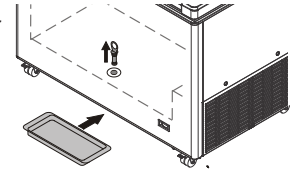

To avoid contamination of food, please respect the following instructions:

- ➡ Opening the door for long periods can cause a significant increase of the temperature in the compartments of the appliance.
- ➡ Clean regularly surfaces that can come in contact with food and accessible drainage systems
- ➡ If the freezer is left empty for long periods, switch off, defrost, clean, dry, and leave the door open to prevent mould developing within the appliance.

Failure to follow these instructions may result in spoilage of food.

- ➡ Commercially available surface disinfectants without acid and without halides (non-dripping)
- ➡ Disinfectants based on alcohol max. 10%
- ➡ After cleaning, remove disinfectant completely from the surfaces with a sterile damp cloth. The device must always be well dried and completely ventilated before commissioning, as explosive gases may be formed during disinfection. A list of tested disinfectants can be requested from the service department.

Technical data

Voltage supply



The precise values for the correct voltage supply are shown on the type plate.

Specification	Value
Type of current	Alternating current
Fuse trip current	Between 10 and 16 A

Storing the appliance after shutting down

NOTICE	Unsuitable room temperature during storage. Damage to property.
	► Ensure that the room temperature is between -10 °C and +50 °C.

- ➡ Ensure that the appliance is dry inside and outside.
- ① **There must be no moisture in the interior container.**
- ➡ Ensure that the room temperature is between -10 °C and +50 °C.

Disposal

NOTICE	Escaping refrigerant and oil. Damage to the environment.
	► Ensure that the refrigerant circuit is not damaged during the disposal process.

- ① The appliance contains recyclable materials and flammable materials.
- ➡ Disconnect the appliance from the power supply.
- ➡ Cut through the mains power cable to render the appliance unusable.
- ➡ Do not simply dispose of the appliance properly with unsorted household refuse.
- ➡ Ensure that the appliance is disposed of in a professional and appropriate way, in accordance with the current local regulations and laws.

Declaration of Conformity

The appliance complies with the relevant safety regulations and EU Directives 2014/30/EU and 2006/42/EC.

Additional information

- Food will remain fresh for longer if stored at the correct temperature. This can prevent having to discard food needlessly.
- If the condenser coil is not cleaned every year, it will significantly reduce the appliance's efficiency.
- The period during which spare parts, necessary for the repair of the refrigerating appliance with a direct sales function, are available is 10 years.
- The minimum duration of the guarantee of the refrigerating appliance with a direct sales function offered by the manufacturer, importer or authorised representative is 2 years.
- EPREL database:
As from 1 March 2021, information about energy labelling and ecodesign requirements will be available in the European product database (EPREL). You can access the product database using the following link: <https://eprel.ec.europa.eu/>. You will be asked to enter the model identifier. You will find the model identifier on the type plate.

Liebherr Appliances Kluang Sdn Bhd (153177-

No.7 Jln Firma 2 , Kaw.Perind.Kluang II, KM7, Jln Mersing, 86007 Kluang, Johor, West Malaysia.
www.liebherr.com.my