

The Perfect Match For Your Kitchen

Quality, Design and Innovation

SIGN 3524

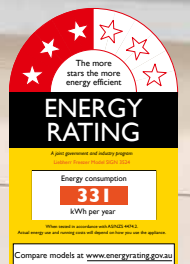

LIEBHERR



Door-on-door technology: Allows custom panels to be affixed directly onto the appliance door so that the hinges are concealed, plus the cabinet and the fridge open as one, ensuring a wide range of design options and easy installation.



MagicEye control system: Our control panel ensures all functions are easy and convenient to use as well as guaranteeing that the settings selected remain accurate and constant.



VarioSpace: The freezer includes drawers and glass shelves that can be conveniently removed to create extra storage space. It's Liebherr's very practical solution to quickly accommodate even bulky items.

The **SIGN 3524** freezer includes transparent, extra-tall and fully removable FrostSafe drawers allow you to efficiently organise frozen food. With FrostSafe, the freezer drawer compartments are closed all round. This means that cold air cannot dissipate as quickly when the door is opened, maintaining the air temperature and ensuring high levels of efficiency. The transparent front of the compartments provides a clear view of the frozen items, so that drawers do not need to be opened as long.

Liebherr's NoFrost technology results in no more manual defrosting and the SuperFrost function saves time and energy to rapidly freeze fresh food. Combine with the **SIKB 3520** fridge for the perfect side by side.

SIGN 3524

Comfort

No Frost

Energy consumption (kWh/yr) Star rating	331 3.0
Compressors	1
Total Usable Litres	213
Freezer Usable Litres	213
MagicEye control system Display	• LCD
Standard lighting	•
Temperature alarm	•
Door open warning signal	•
Malfunction warning signal	•
Freezer defrosting	Frost Free
FrostSafe system - transparent drawers	•
Freezer drawers	8
SuperFrost	•
VarioSpace	•
24hr freezing capacity (kg)	18
Door hinges	Left, reversible
Voltage (V) Rated Current (A)	220-240 1.3
Made in	Germany

Installation Diagram

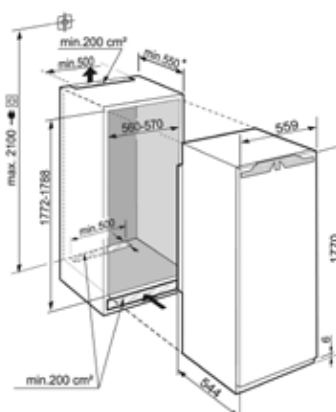

* Recommended: 560 mm

Note: Whilst every effort is made to ensure all specifications and information in this flyer are accurate, Liebherr reserves the right to make changes without notification. Where actual appliance measurements, specifications, and ratings are crucial, we recommend that the actual appliance installation instructions that accompany each appliance be checked. Liebherr will not be liable for any loss.