



USER GUIDE & INSTALLATION INSTRUCTIONS

Nexus
110 Induction / Steam
Australia

U111144-05a

Contents

| | | | |
|---|-----------|---|-----------|
| 1. Before You Start... | 1 | 5. The Steam Cavity | 24 |
| Personal Safety | 1 | Operating the Steam Cavity | 25 |
| Electrical Connection Safety | 2 | Steam Cavity Functions | 26 |
| Peculiar Smells | 3 | Using the Steam Grill | 26 |
| Ventilation | 3 | Program Modes | 27 |
| Maintenance | 3 | The Clock / Timer | 28 |
| Induction care | 4 | 6. Cleaning Your Cooker | 29 |
| Grill/Glide-out Grill™ Care | 7 | Hob | 29 |
| Cooling Fan | 7 | Induction Griddle (some models only) | 30 |
| Cooker Care | 7 | Glide-out Grill™ | 30 |
| Cleaning | 8 | Control Panel and Doors | 31 |
| 2. Cooker Overview | 9 | Multifunction Oven | 31 |
| The Hob | 9 | Steam Cavity | 32 |
| Pan Detector, | 10 | Cleaning Table | 33 |
| Residual Heat Indicator, <i>H</i> | 11 | 7. Troubleshooting | 34 |
| Child Lock,  | 11 | 8. Installation | 37 |
| Low Temperature Setting, <i>L1/L2/L3</i> | 11 | Dear Installer | 37 |
| Power Boost Setting, <i>P</i> | 12 | Safety Requirements and Regulations | 37 |
| Power Sharing Zones | 12 | Provision of Ventilation | 37 |
| The Bridging-Zone Function, <i>f</i> | 12 | Location of Cooker | 37 |
| Overheat Function | 13 | Positioning the Cooker | 38 |
| The Glide-out Grill™ | 13 | Moving the Cooker | 38 |
| Bread Proving Drawer | 14 | Lowering the Two Rear Rollers | 39 |
| Telescopic shelf - <i>Left-hand (Main) Oven</i> | 15 | Completing the Move | 39 |
| 3. Using the Glide-out Grill™ | 16 | Fitting the Stability Bracket | 39 |
| 4. The Multifunction Oven | 17 | Repositioning the Cooker Following Connection | 39 |
| Operating the Multifunction Oven | 17 | Levelling | 39 |
| Accessories | 19 | Electrical Connection | 40 |
| Cooking Tips | 22 | Connection in New Zealand | 41 |
| Cooking Table | 23 | Fixed Wiring | 41 |
| | | Final Checks | 42 |
| | | Final Fitting | 42 |
| | | Customer Care | 42 |
| | | 9. Servicing | 43 |
| | | 10. Circuit Diagram | 47 |
| | | Power PCB | 49 |
| | | 11. Technical Data | 50 |

1. Before You Start...

Your cooker should give you many years of trouble-free cooking if installed and operated correctly. It is important that you read this section before you start.

Personal Safety

This appliance is for cooking purposes only. It must not be used for other purposes, for example heating a room. Using it for any other purpose could invalidate any warranty or liability claim. Besides invalidating claims this wastes fuel and may overheat the control knobs.

- This appliance can be used by children aged from 8 years and above and persons with reduced physical, sensory or mental capabilities or lack of experience and knowledge if they have been given supervision or instruction concerning use of the appliance in a safe way and understand the hazards involved.
- **WARNING:** Children **less** than 8 years of age should be kept away unless continuously supervised. Children shall not play with the appliance. Cleaning and user maintenance shall not be made by children without supervision.
- Suitable only for indoor installation.
- **DO NOT** operate this appliance before reading the instruction booklet.
- **DO NOT** place articles on or against this appliance.
- **DO NOT** operate with panels, covers or guards removed from this appliance.
- The cooker should not be placed on a base.
- This appliance is designed for domestic cooking only. Use for any other purpose could invalidate any warranty or liability claim.
- Before operating the ovens please refer to the oven shelf installation, in the Accessories section.
- **WARNING:** The appliance and its accessible parts become hot during use and will retain heat even after you have stopped cooking. Care should be taken to avoid touching heating elements. Children less than 8 years of age shall be kept away unless continuously supervised.
- **CAUTION:** A long term cooking process has to be supervised from time to time. A short term cooking process has to be supervised continuously.
- At the risk of fire **DO NOT** store items on the cooking surfaces.
- To avoid overheating, **DO NOT** install the cooker behind a decorative door.
- **WARNING:** Accessible parts will become hot during use and will retain heat even after you have stopped cooking. Keep babies and children away from the cooker and never wear loose-fitting or hanging clothes when using the appliance.
- **DO NOT** use a steam cleaner on your cooker.
- Always keep combustible materials, e.g. curtains, and flammable liquids a safe distance away from the cooker.
- **DO NOT** spray aerosols in the vicinity of the cooker while it is on.

Fig. 1.1

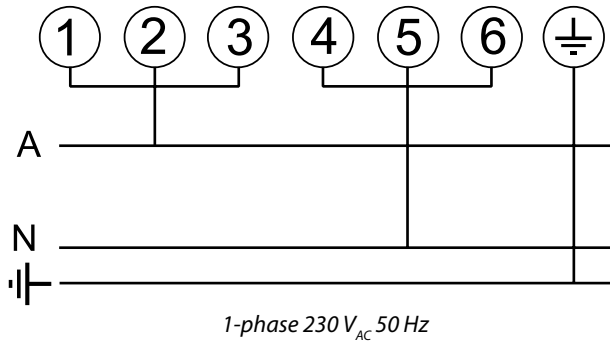
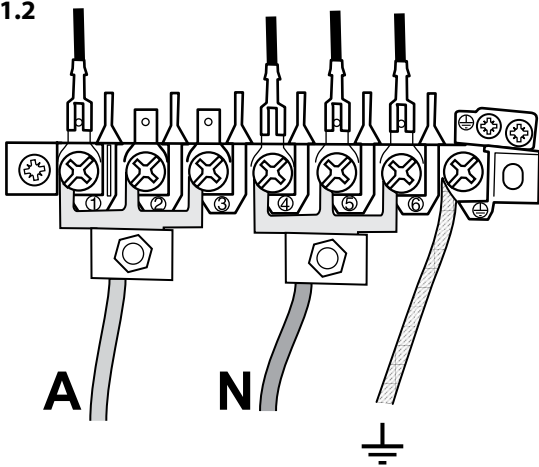

Fig. 1.2



Electrical Connection Safety

⚠ WARNING: THE APPLIANCE MUST BE EARTHED.

The cooker is preset for a single-phase earthed electrical connection. It is essential to install a multi-pole circuit breaker that completely disconnects the appliance from the mains, with a minimum contact break distance of 3 mm.

The total electrical load of the appliance is approximately 12.15 kW. The cable size used should be suitable for this load and comply with all local requirements (i.e. PVC Insulated cable IEC 60227 – code 53 for ordinary cables).

Access to the mains terminal is gained by removing the electrical terminal cover box on the back panel. Connect the mains cable to the correct terminals for your electrical supply type (**Fig. 1.1** and **Fig. 1.2**). Check that the links are correctly fitted and that the terminal screws are tight. Secure the mains cable using the cable clamp.

Minimum temperature rating T105.

Read the instructions before installing or using this appliance.

- This appliance is heavy so take care when moving it.
- The cable size and type should be suitable for the Electrical Load of the appliance and comply with the relevant national and local requirements.
- The cooker may be installed in a kitchen/ kitchen diner but **NOT** in a room containing a bath or shower.
- The cooker **MUST NOT** be connected to an ordinary domestic power point.
- It is normal for the hob control display to flash for about 2 seconds during first power setting.
- Set the clock to make sure that the oven is functional – see the relevant section in this manual.

- The appliance must be installed in accordance with the regulations in force and only in a well ventilated space.
- Failure to install the appliance correctly could invalidate any warranty or liability claims and lead to prosecution.
- **DO NOT** install the appliance on a platform.
- **DO NOT** manoeuvre the cooker while it is plugged into the electricity supply.
- Before electrical reconnection, check that the appliance is electrically safe.

Peculiar Smells

When you first use your cooker it may give off an odour. This should stop after use.

Before using for the first time, make sure that all packing materials have been removed and then, to dispel manufacturing odours, turn the ovens to 200°C and run for at least an hour.

Before using the grill for the first time you should also turn on the grill and run for 30 minutes with the grill pan in position, pushed fully back and the grill door open.

Make sure the room is well ventilated to the outside air (see 'Ventilation' below). People with respiratory or allergy problems should vacate the area for this brief period.

Ventilation

The use of a cooking appliance results in the production of heat and moisture in the room in which it is installed. Therefore, make sure that the kitchen is well ventilated: keep natural ventilation holes open or install a powered cookerhood that vents outside. If you have several hotplates/burners on, or use the cooker for a long time, open a window or turn on an extractor fan

Maintenance

- It is recommended that this appliance is serviced annually.
 - **WARNING:** Before replacing the bulb, turn off the power supply and make sure that the oven is cool.
 - **DO NOT** use cooking vessels on the hotplate that overlap the edges.
 - Unless specified otherwise in this guide, always allow the cooker to cool and then switch it off at the mains before cleaning or carrying out any maintenance work.
 - **DO NOT** use the control knobs to manoeuvre the cooker.
 - **NEVER** operate the cooker with wet hands.
 - **DO NOT** use a towel or other bulky cloth in place of a glove – it might catch fire if brought into contact with a hot surface.
 - **DO NOT** use hotplate protectors, foil or hotplate covers of any description. These may affect the safe use of your hotplate burners and are potentially hazardous to health.
 - **NEVER** heat unopened food containers. Pressure build up may make the containers burst and cause injury.
 - **DO NOT** use unstable saucepans. Always make sure that you position the handles away from the edge of the hotplate.
 - **NEVER** leave the hotplate unattended at high heat settings. Pans boiling over can cause smoking, and greasy spills may catch on fire. Use a deep fat thermometer whenever possible to prevent fat overheating beyond the smoking point.
- ▲ WARNING: Unattended cooking on a hob with fat or oil can be dangerous and may result in fire.**

- ▲ **NEVER** try to extinguish a fire with water, but switch off the appliance and then cover the flame e.g. with a lid or a fire blanket.
- **NEVER** leave a chip pan unattended. Always heat fat slowly, and watch as it heats. Deep fry pans should be only one third full of fat.
- **WARNING: Danger of fire: do not store items on the cooking surfaces.**
- **NEVER** try to move a pan of hot fat, especially a deep fat fryer. Wait until the fat is cool. Filling the pan too full of fat can cause spill over when food is added. If you use a combination of oils or fats in frying, stir them together before heating, or as the fats melt.
- Foods for frying should be as dry as possible. Frost on frozen foods or moisture on fresh foods can cause hot fat to bubble up and over the sides of the pan. Carefully watch for spills or overheating of foods when frying at high or medium high temperatures.
- **DO NOT** use the top of the flue (the slot along the back of the cooker) for warming plates, dishes, drying tea towels or softening butter.
- **DO NOT** use water on grease fires and never pick up a flaming pan. Turn the controls off and then smother a flaming pan on a surface unit by covering the pan completely with a well fitting lid or baking tray. If available, use a multi-purpose dry chemical or foam-type fire extinguisher.
- **DO NOT** modify this appliance. This appliance is not intended to be operated by means of external timer or separated remote-control system.
- If flammable materials are stored in the drawer, oven(s) or grill(s) it may explode and result in fire or property damage.

Induction care

- **IMPORTANT INFORMATION FOR PACEMAKER AND IMPLANTED INSULIN PUMP USERS:** The functions of this hob comply with the applicable European standards on electromagnetic interference. If you are fitted with a pacemaker or implanted insulin pump and are concerned please consult your doctor for medical advice.
- When the hob is in use keep magnetic items away, such as credit and debit cards, floppy disk, calculators, etc.
- To fully utilise the power of your induction hob and to ensure longevity of performance, we recommend the use of AGA Rangemaster Induction cookware. If you decide to purchase an alternative set of cookware for use on your induction cooker, we would strongly recommend that composite aluminium cookware with steel inserts, example shown **Fig. 1.3**, are avoided. This type of construction can significantly reduce the lifetime and performance of your induction cook top.
- Take care when touching the marked cooking areas of the hob.
- Use adequately sized pans with flat bottoms that are large enough to cover the surface of the hotplate heating area. The use of undersized pans will expose a portion of the surface unit to direct contact and may result in the ignition of clothing.
- Only certain types of glass, glass-ceramic, earthenware or other glazed containers are suitable for use on the warming zone; others may break because of the sudden change in temperature.
- Only certain types of stainless steel, enamelled steel or cast iron cookware with enamelled bases are suitable for induction hob cooking.

- Take care **NOT** to scratch the surface when placing cookware on the glass panel.
- Only certain types of glass, glass-ceramic, earthenware or other glazed containers are suitable for hotplate cooking; others may break because of the sudden change in temperature. **NEVER** cook directly on the hob surface (**Fig. 1.4**).
- **DO NOT** leave the hob zones switched on unless being used for cooking.
- **DO NOT** stand or rest heavy objects on the hob. Although the ceramic surface is very strong, a sharp blow or sharp falling object (e.g. a salt cellar) might cause the surface to crack or break (**Fig. 1.5**).
- **WARNING:** Should a crack appear in the surface, disconnect the appliance immediately from the supply and arrange for its repair.
- **ALWAYS LIFT** cookware off the hob. Sliding the griddle plate or pans may cause marks and scratches (**Fig. 1.6**).
- Take care **NOT TO PLACE HOT LIDS** onto the hob surface (**Fig. 1.7**). Lids that have been used to cover a hot pan can “stick” or create a “vacuum” effect to the Glass Hob. Should this occur, **DO NOT** attempt to lift the lid off the glass surface, this may damage the glass. Instead slide the lid to the edge of the hob surface and remove, taking care not to scratch the hob surface. Alternatively wait until the lid has cooled to room temperature, the vacuum has been released, then remove the lid by lifting it from the hob surface.
- **DO NOT** place anything between the base of the pan and the hob surface (e.g. asbestos mats, aluminium foil, wok stand).
- Take care **NOT** to place metallic objects such as knives, forks, spoons and lids on the hob surface since they can get hot.

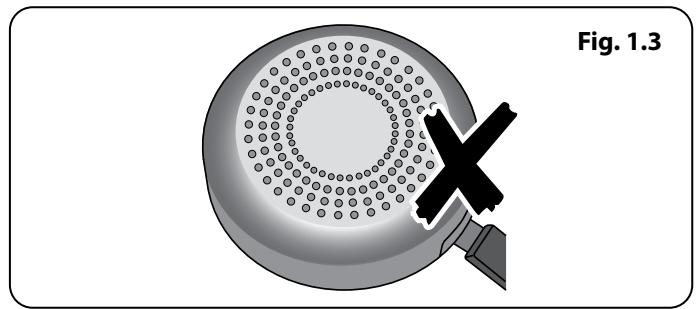

Fig. 1.3

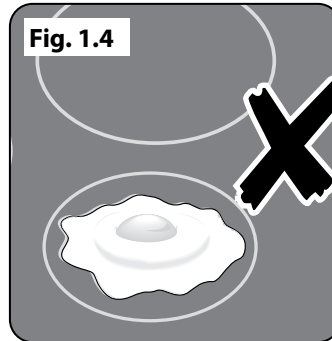

Fig. 1.4

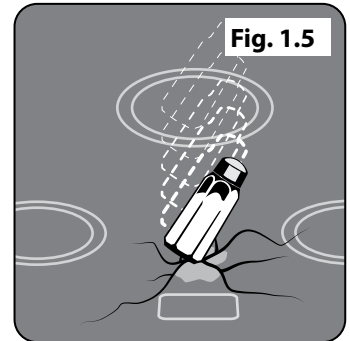

Fig. 1.5

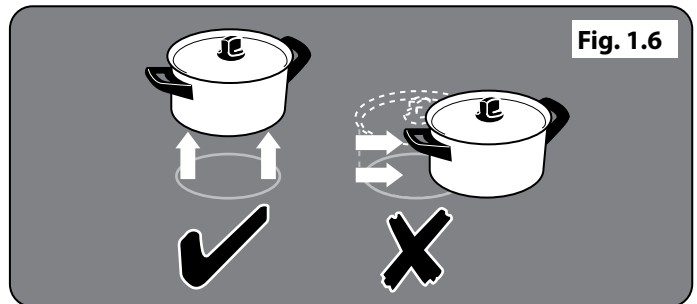

Fig. 1.6

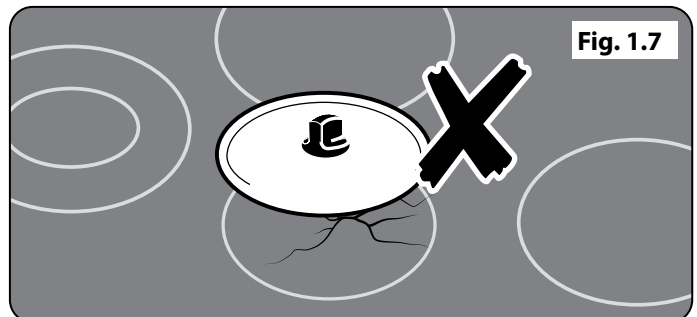
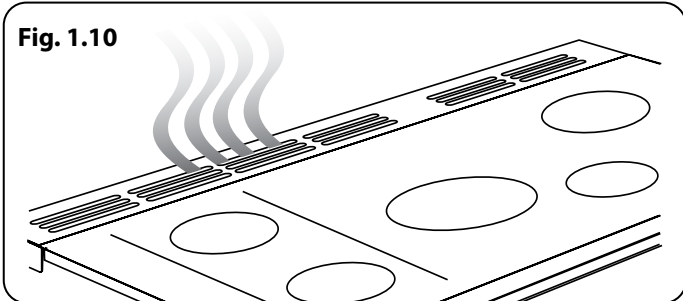
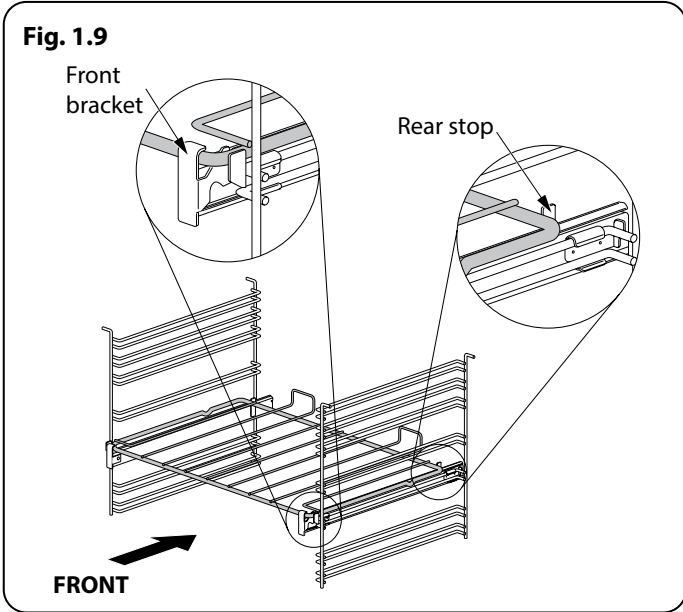
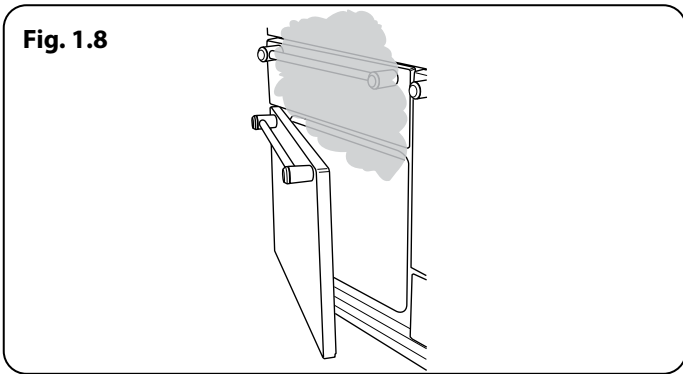

Fig. 1.7



- We recommend that you avoid wiping any surface unit areas until they have cooled and the indicator light has gone off. Sugar spills are the exception to this (see 'Cleaning your Cooker'). After cleaning, use a dry cloth or paper towel to remove any cleaning cream residue.
- The ceramic surface should be washed after use in order to prevent it from becoming scratched or dirty. However, you should clean the hob with caution as some cleaners can produce noxious fumes if applied to a hot surface.
- **DO NOT** leave the hob unattended. Care should be taken to not allow your cookware to boil dry. It will damage your cookware and Induction Glass Hob.
- After use, switch off the hob element by its control. **DO NOT** rely on the pan detector.

Oven Care

- When the oven is not in use and before attempting to clean the cooker always be certain that the control knobs are in the **OFF** position.
- Use oven gloves to protect your hand from potential burns.
- Cooking high moisture content foods can create a 'steam burst' when the oven door is opened (**Fig. 1.8**). When opening the oven, stand well back and allow any steam to disperse.
- The inside door face is constructed with toughened safety glass. Take care **NOT** to scratch the surface when cleaning the glass panel.
- Accidental damage may cause the door glass panel to fracture.
- Keep oven vent ducts unobstructed.
- **DO NOT** use harsh abrasive cleaners or sharp metal scrapers to clean the oven door glass since they can scratch the surface, which may result in shattering of the glass.

- Make sure the shelves are pushed firmly to the back of the oven. **DO NOT** close the door against the oven shelves.
- **DO NOT** use aluminium foil to cover shelves, linings or the oven roof.
- When the oven is on, **DO NOT** leave the oven door open for longer than necessary, otherwise the control knobs may become very hot.
- **DO NOT** use the timed oven if the adjoining oven is already warm.
- **DO NOT** place warm food in the oven to be timed.
- **DO NOT** use a timed oven that is already warm.
- Use dry oven gloves when applicable – using damp gloves might result in steam burns when you touch a hot surface.
- **DO NOT** place plastic or aluminium foil, or plastic containers on the hob.
- Always turn the control to the **OFF** position before removing a pan.
- Avoid heating an empty pan. Doing so may damage both the hob and pan.

Grill/Glide-out Grill™ Care

- When using the grill, make sure that the grill pan is in position and pushed fully in, otherwise the control knobs may become very hot.
- **DO NOT** leave the grill on for more than a few moments without the grill pan underneath it, otherwise the knobs may become hot.
- **NEVER** close the grill door when the grill is on.
- Accessible parts may be hot when the grill is in use. Young children should be kept away

Oven Shelves

To fit the glide-out shelf, hook the front of the shelf onto the runners as shown (**Fig. 1.9**). The rear of the shelf should rest on the runners, in front of the rear stop (**Fig. 1.9**).

Steam oven shelves can be fitted by lining up the shelf with a groove in the oven ladders. Push the shelf back until the ends hit the shelf stop. Lift the front so the shelf clears the stops, then lower the front so the shelf is level and push it fully back.

Hob Care

- **NEVER** allow anyone to climb or stand on the hob.
- **DO NOT** use the hob surface as a cutting board.
- **DO NOT** leave utensils, foodstuffs or combustible items on the hob when it is not in use (e.g. tea towels, frying pans containing oil).

Cooling Fan

This appliance may have a cooling fan. When the grill or ovens are in operation the fan will run to cool the fascia and control knobs.

Cooker Care

As steam can condense to water droplets on the cool outer trim of the oven, it may be necessary during cooking to wipe away any moisture with a soft cloth. This will also help to prevent soiling and discolouration of the oven exterior by cooking vapours (**Fig. 1.10**).

Cleaning

- Isolate the electricity supply before carrying out any thorough cleaning. Allow the cooker to cool.
- In the interests of hygiene and safety, the cooker should be kept clean at all times as a build up in fats and other food stuff could result in a fire.
- Clean only the parts listed in this guide.
- Clean with caution. If a wet sponge or cloth is used to wipe spills on a hot surface, be careful to avoid steam burns. Some cleaners can produce noxious fumes if applied to a hot surface.
- **NEVER** use paint solvents, washing soda, caustic cleaners, biological powders, bleach, chlorine based bleach cleaners, coarse abrasives or salt.
- **DO NOT** mix different cleaning products – they may react together with hazardous results.
- All parts of the cooker can be cleaned with hot soapy water.
- Take care that no water seeps into the appliance.
- Before you remove any of the grill parts for cleaning, make sure that they are cool or use oven gloves.
- **DO NOT** use any abrasive substances on the grill and grill parts.
- **DO NOT** put the side runners in a dishwasher.
- **DO NOT** put the burner heads in a dishwasher.
- **NEVER** use caustic or abrasive cleaners as these will damage the surface.
- **DO NOT** use steel wool, oven cleaning pads or any other materials that will scratch the surface.
- **NEVER** store flammable materials in the drawer. This includes paper, plastic and cloth items, such as cookbooks, plastic ware and towels, as well as flammable liquids.
- **DO NOT** store explosives, such as aerosol cans, on or near the appliance.
- **DO NOT** use steel wool, oven cleaning pads, or any other materials that will scratch the surface.
- **DO NOT** attempt to disassemble or clean around any burner while another burner is on, otherwise an electric shock could result.

2. Cooker Overview

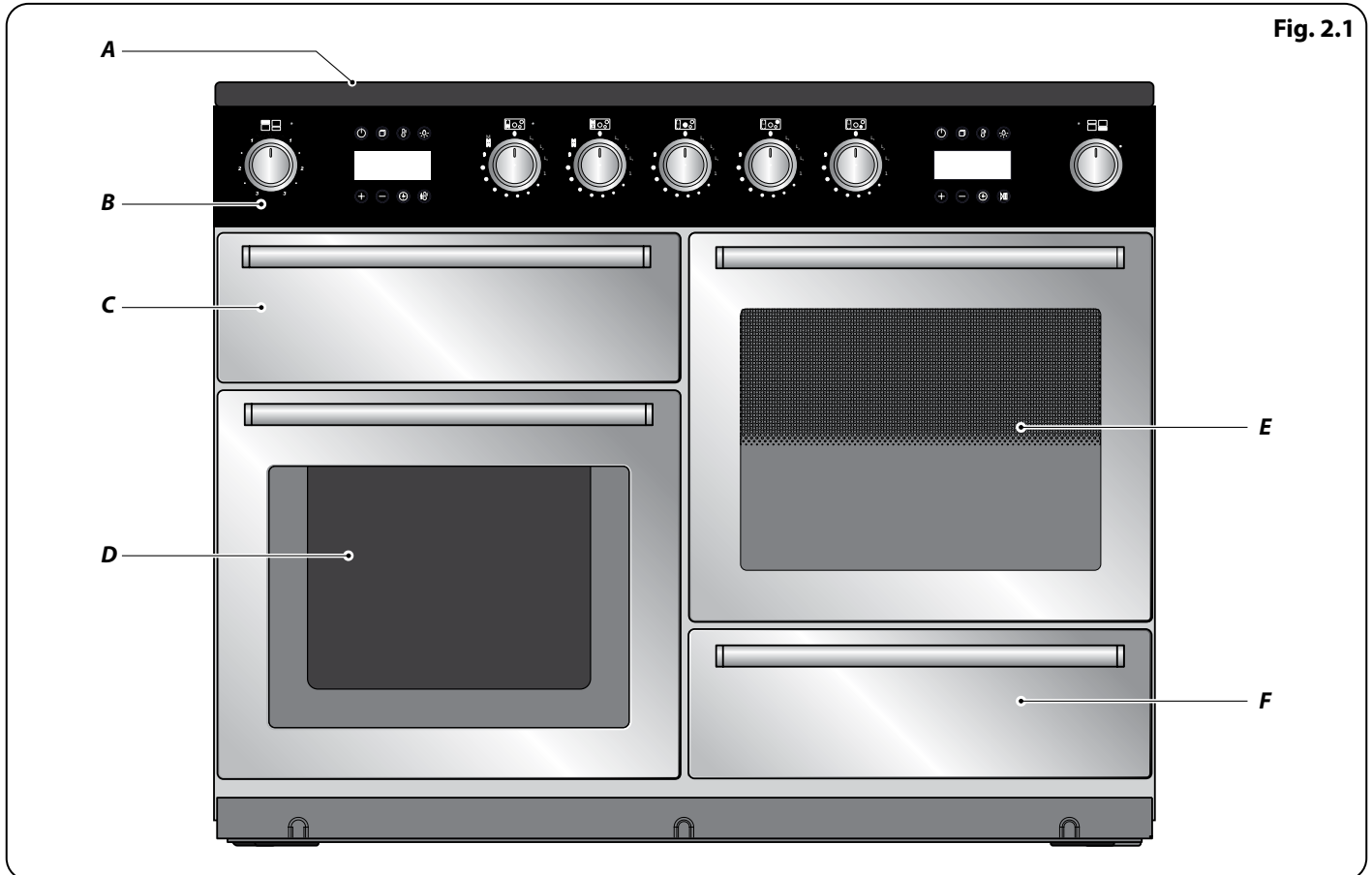

Your 110 induction cooker (**Fig. 2.1**) has the following features:

- A. 5 induction cooking zones
- B. Control panel
- C. Glide-out grill with 4 position trivet
- D. Multifunction oven
- E. Steam cavity
- F. Bread Proving/Storage Drawer

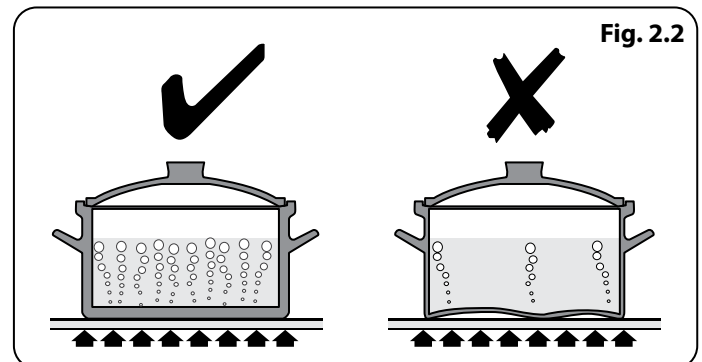

The Hob

Use only pans that are suitable for induction hobs. We recommend stainless steel, enamelled steel pans or cast iron pans with enamelled bases. Note that some stainless steel pans are not suitable for use with an induction hob so please check carefully before purchasing any cookware.

Pans made of copper, aluminium or ceramic are not suitable for use on an induction hob. The kind of pan you use and the quantity of food affects the setting required. Higher settings are required for larger quantities of food.

Pots and pans should have thick, smooth, flat bottoms (**Fig. 2.2**). This allows the maximum heat transfer from the hob to the pan, making cooking quick and energy efficient. Never use a round-bottomed wok, even with a stand.

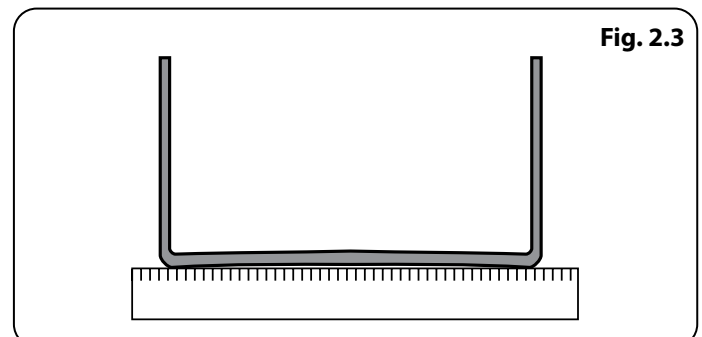

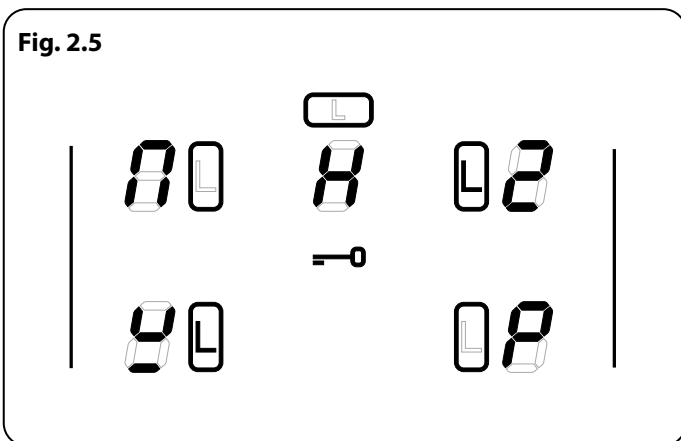
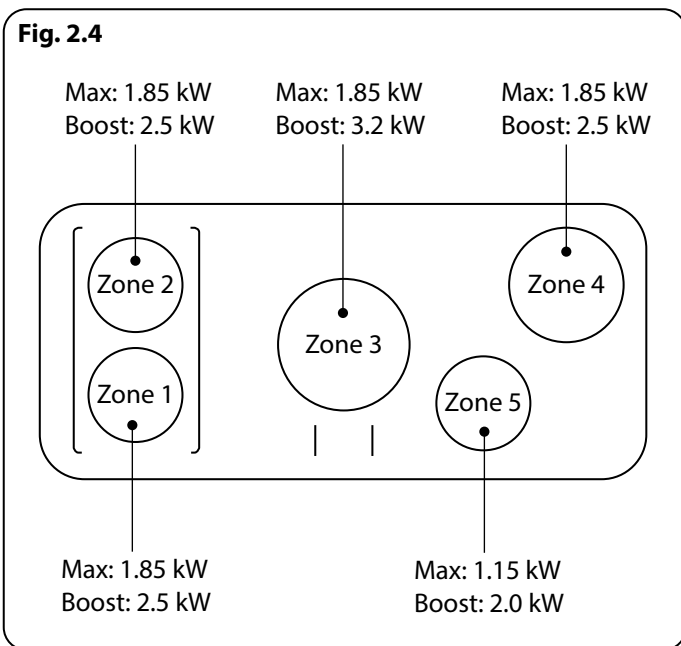

| Cooking Zone | Minimum Pan Diameter (pan base) mm |
|--------------|------------------------------------|
| Front Left | 180 |
| Rear Left | 180 |
| Centre | 210 |
| Rear Right | 180 |
| Front Right | 140 |

Table 2.1

The very best pans have bases that are very slightly curved up when cold (**Fig. 2.3**). If you hold a ruler across the bottom you will see a small gap in the middle. When they heat up the metal expands and lies flat on the cooking surface.

Make sure that the base of the pan is clean and dry to prevent any residue burning onto the hob panel. This also helps prevent scratches and deposits.

Always use pans that are the same size as (or slightly larger than) the areas marked on the hob. Using a lid will help the contents boil more quickly.

The induction hob comprises of five cooking zones containing induction elements with different ratings and diameters (**Fig. 2.4**) each with a pan detector and residual heat indicator, and a hob control display.

The hob control display (**Fig. 2.5**) informs you of the following induction hob functions:

- Pan Detector
- *H* Residual Heat Indicator
- Child Lock
- *L1/L2/L3* Low Temperature Setting
- *P* Power Boost Setting

Pan Detector,

If a cooking area is switched on and there is no pan in place or if the pan is too small for the cooking area, then no heat will be generated. The symbol [] will appear on the hob control display; this is the “pan-missing symbol”. Place a pan of the correct size on the cooking area and the [] symbol will disappear and cooking can begin. After 10 minutes without detecting a pan the cooking zone will switch off automatically.

Table 2.1 shows the minimum pan sizes recommended for each cooking zone.

NOTE: Using pans with a base diameter smaller than those recommended will result in a power reduction.

Residual Heat Indicator, *H*

After use, a cooking zone will remain hot for a while as heat dissipates. When a cooking zone is switched off the residual heat indicator symbol [*H*], will appear in the display. This shows that the cooking zone temperature is above 60 °C and may still cause burns. Once the temperature has dropped to below 60 °C the [*H*] will go out.

Child Lock, $\rightarrow 0$

⚠ IMPORTANT: The child lock can only be activated when all the cooking zones are switched off.

To prevent the unwanted use by children, the hob can be locked.

To lock the hob, simultaneously turn the two left-hand controls counter-clockwise (**Fig. 2.6**) and hold until the $\rightarrow 0$ symbol appears in the centre of the hob control display (**Fig. 2.7**).

NOTE: [*H*] will flash when locking the hob – this is normal.

Locking the hob will **NOT** affect the ovens; they can still be used.

To unlock the hob, simultaneously turn the two left-hand controls counter-clockwise and hold until the $\rightarrow 0$ symbol disappears from the centre of the hob control display.

Low Temperature Setting, *L1/L2/L3*

⚠ This function should only be used when heating from cold

Each cooking area is equipped with 3 low temperature settings:

- *L1* will maintain a temperature of about 44 °C – ideal for gently melting butter or chocolate.
- *L2* will maintain a temperature of about 70 °C – ideal for keeping food warm, once it is cooked.
- *L3* will maintain a temperature of about 94 °C – ideal for simmering (bring the pan to the boil and then select *L3* to keep soups, sauces, stews, etc at an optimal simmer).

The maximum time these settings can be used is 2 hours, after which the hob will switch off automatically. If required, you can immediately restart the Low Temperature function by reactivating *L1* or *L2*. To increase the heat, just turn the control knob to the required level.

The maximum times for all other power levels are shown in **Table 2.2**.

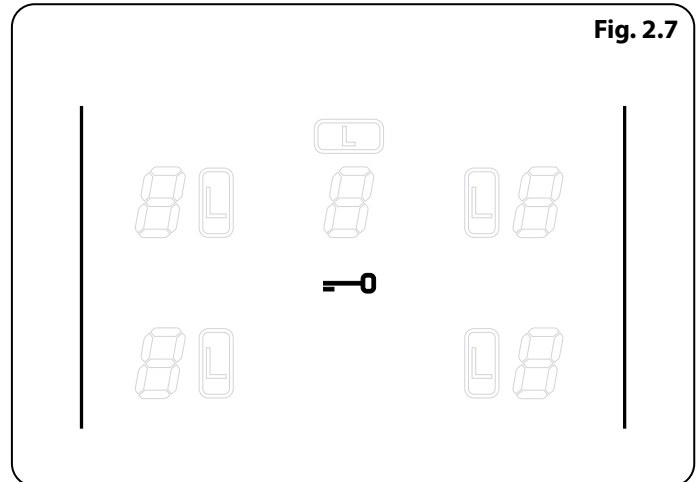
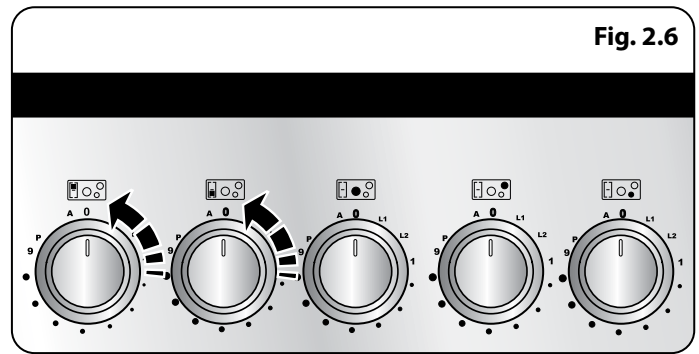

| Power Level | Maximum Operating Time |
|----------------------|------------------------|
| <i>L1, L2 and L3</i> | 2 hours |
| 1 | 6 hours |
| 2 | 6 hours |
| 3 | 5 hours |
| 4 | 5 hours |
| 5 | 4 hours |
| 6 | 1.5 hours |
| 7 | 1.5 hours |
| 8 | 1.5 hours |
| 9 | 1.5 hours |
| Power Boost | 10 minutes |

Table 2.2

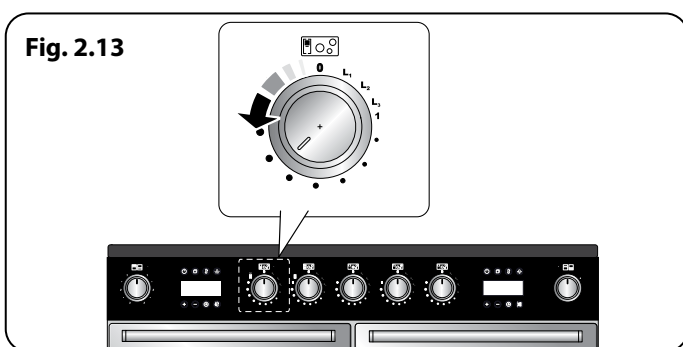
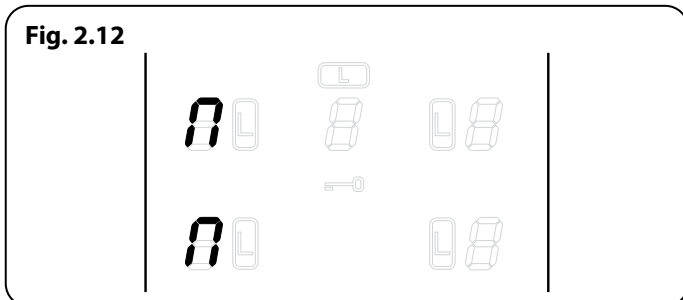
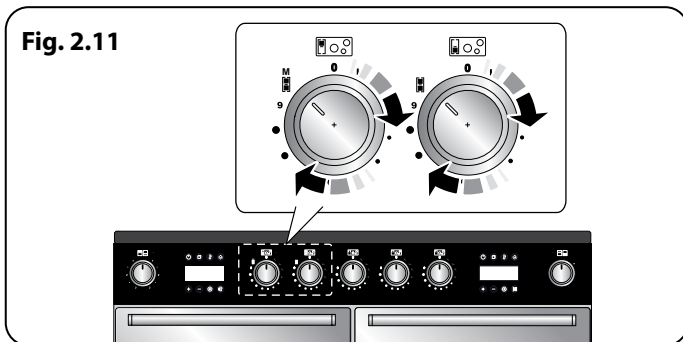
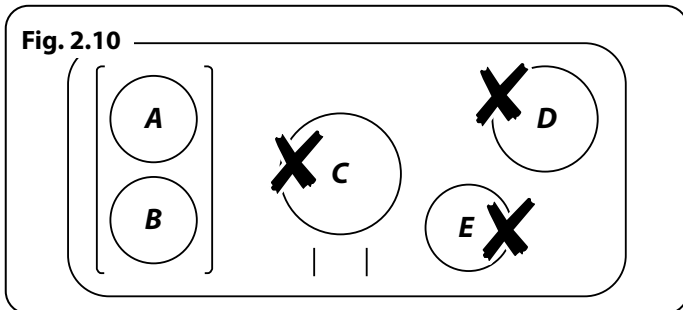
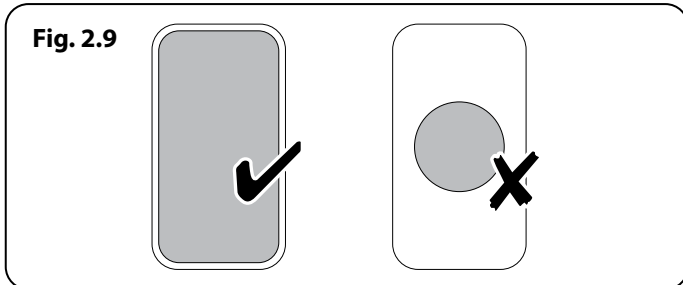
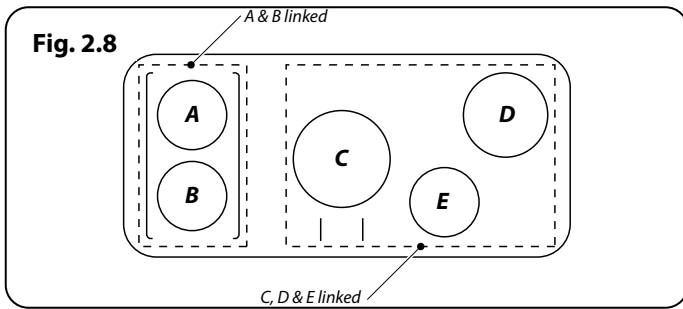

Power Boost Setting, P

All of the induction cooking zones have Power Boost available, activated by turning the control knob clockwise until [P] is shown on the hob control display.

Power Boost allows additional power to be made available for each of the cooking zones. This is useful to bring a large pan of water to the boil quickly.

The Power Boost function operates for a maximum of 10 minutes on each zone, after which the power is automatically reduced to setting 9.

Deactivate the Power Boost function by turning the control knob to a lower setting.

Power Sharing Zones (Fig. 2.8)

Power sharing is taking the power from the adjacent zone. For example, if zones C, D and E (Fig. 2.8) are set to power level 9, or set to Power Boost (P) the power level in D or E will adjust in the order it was switched on.

⚠ Avoid heating an empty pan. Doing so may damage both the hob and pan.

Example 1: Set zone C to power level 9, switch on zone D to power level 9 and then zone E to power level 9. After a few seconds zone D power level will reduce to 7. **Zone C will remain at P or 9**

Example 2: Set zone C to power level 9, switch on zone E to power level 9 and then zone D to power level 9. After a few seconds zone E power level will reduce to 6. **Zone C will remain at P or 9**

Example 3: Set zone D and E to power level 9 and then zone C to power level 9. After a few seconds zone E power level will reduce to 6.

The same principle applies when using zone A and B. When using zone A on Power Boost (P) and then switching zone B to Power Boost (P), the power to zone A will reduce slightly.

⚠ This is a built-in safety device.

The Bridging-Zone Function, Π

Zones A and B can be bridged, creating an area, ideal for use with an induction griddle plate (supplied).

Note: The griddle plate should comprise of an induction friendly, flat bottom, large enough to cover zones A and B of the hotplate heating area (Fig. 2.9).

DO NOT use zones C, D or E to heat the griddle plate (Fig. 2.10).

To activate the bridging-zone function, simultaneously turn the two left-hand controls completely clockwise (Fig. 2.11) and hold until the [Π] symbols appear in the centre of the hob control display (Fig. 2.12). The temperature can then be adjusted using the left-hand knob (Fig. 2.13).

Turn both knobs counter-clockwise to cancel the dualzone function and return to normal operation.

⚠ DO NOT turn the two left-hand knobs individually to heat the griddle plate. This can cause excessive temperatures and damage the coating on the griddle plate.

Overheat Function

This function identifies when the temperature of the pan rises rapidly and works to maintain a safe level of pan temperature. It should not interfere with normal cooking.

Cookware with bases that become distorted (**Fig. 2.2**) when heated may interfere with the operation of the Overheat Function. This may result in damage to your cookware or Induction Glass Hob.

Please read and follow the manufacturers' instructions carefully before using cookware on your induction hob.

The Glide-out Grill™ (Fig. 2.14)

⚠ WARNING: When the trivet has been removed from the grill pan, please ensure that the grill pan and cradle are fully returned into the grill chamber. The grill pan door MUST remain open.

⚠ Accessible parts may be hot when the broiler is in use. Young children should be kept away.

⚠ Never close the grill door when the grill is on.

1. For best results, slide the carriage back into the grill chamber. The grill trivet can be removed and the food placed on it while you are waiting for the grill to preheat.
2. **DO NOT** leave the grill on for more than a few moments without the grill pan underneath it, otherwise the knobs may become hot.
3. Once the grill has preheated, slide the carriage out again. With the trivet back in place with the food on it, slide the carriage back into the grill chamber. Make sure that it is pushed right in.

The grill pan trivet can be turned to give four grilling heights by a combination of turning it back to front and turning it upside down. See chapter **Using the Glide-out Grill™**.

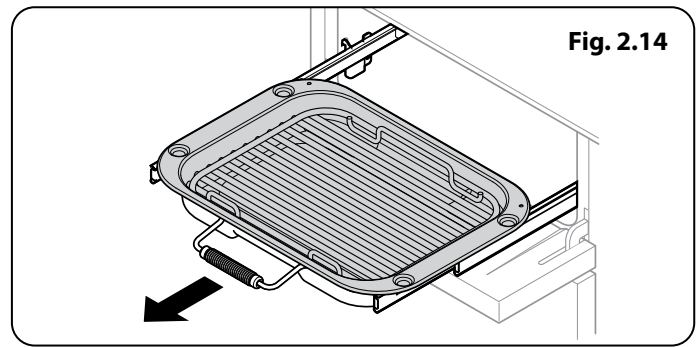

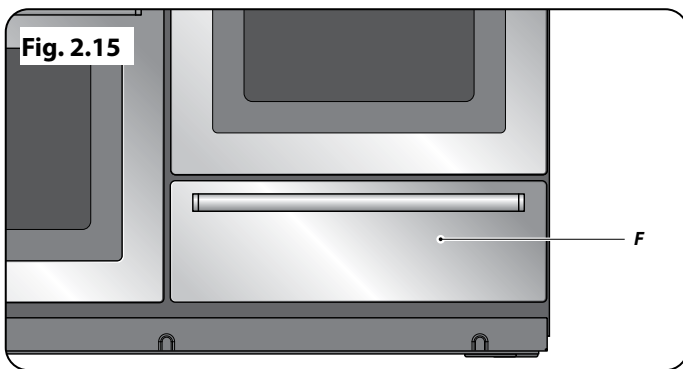

Bread Proving Drawer

The Bread Proving Drawer is found on the right at the base of the cooker (**Fig. 2.15**). Within the Bread Proving Drawer there are slots in the base to allow warmed air to flow through into the drawer from the element underneath.

The Bread Proving Drawer temperature is ideal for proving all sorts of yeast dough from sweet to savoury, gluten free to sourdough, dough made from fresh yeast and dried, bread mixes and recipes from the Rangemaster Good Housekeeping Cookery book.

Pre heat the drawer so that it is warm and ready for your dough.

Turn the knob clockwise (**Fig. 2.16**). There is no need to set the temperature, this is already set.

The Bread Proving Drawer has space for:

- Baking trays, no larger than 340mm x 340mm, to prove bread rolls or buns; these can then be put straight into a preheated oven after proving.
- To prove 2 trays at once in the drawer use a cooling rack or trivet over the top of one tray with the other on top, remember to allow space for the dough to expand during the proving time.
- 3 litre bowl full of dough
- 3 x 2 pound loaf tins
- 4 x 1 pound loaf tins

The time needed for proving will depend upon the dough type and the amount. Refer to the recipe for guidance and check the dough during the proving time.

If a large baking tray is used, place a cooling rack on to the base of the drawer, and put the tray on top, this will allow the warmed air to reach the dough.

When preparing larger quantities of yeast dough, containing 500g or over of flour, divide the dough into 2 bowls or containers, this will make proving in the drawer easier.

Keep an eye on the dough while it is proving; fresh yeast can work quickly especially if it has had a first fermentation stage (sometimes called sponging). Sponging can help produce a slightly lighter loaf.

The Bread Proving Drawer can be used for storage. If you have used the Bread Proving Drawer, switch it off and wait until the drawer cools before storing any items.

NOTE: The Bread Proving Drawer will not warm plates.

Cleaning

Clean the inside of the drawer with hot soapy water and a soft cloth, rinse and dry.

The Bread Proving Drawer is ideal for storing baking trays and other cooking utensils.

It can get very warm, so do not store anything in it that may melt or catch fire. Never store flammable materials in the drawer. This includes paper, plastic and cloth items, such as cookbooks, plastic ware and towels, as well as flammable liquids. Do not store explosives, such as aerosol cans, on or near the appliance.

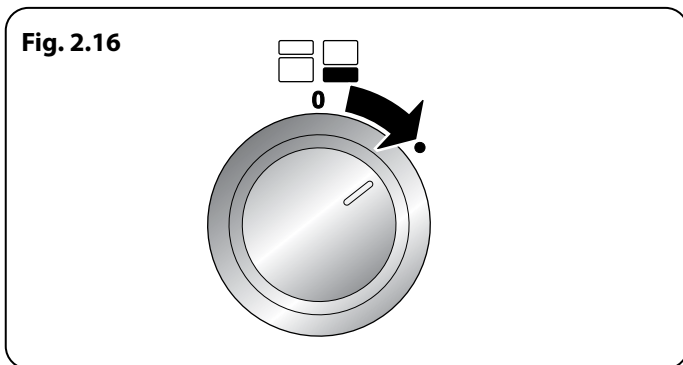

TOP TIPS

Not sure of the capacity of your loaf tins?

- A one pound loaf tin will hold 800ml of water
- A two pound loaf tin will hold 1.5 litres of water.
- Cover the dough while it is proving with greased cling film, be careful not to anchor the cling film too tightly so that it prevents the dough from rising.

Telescopic shelf - Left-hand (Main) Oven

As well as standard shelves, the left-hand oven is supplied with a set of runners for a glide-out oven shelf.

To fit the glide-out shelf, hook the front of the shelf onto the runners as shown (Fig. 2.17). The rear of the shelf should rest on the runners, in front of the rear stop (Fig. 2.17).

The glide-out shelf and runners can be easily removed or repositioned.

To remove the glide-out shelf

Raise the rear of the shelf, so that it clears the rear stops. Then unhook from the front locating bracket.

To remove the glide-out runners

Twist to unclip the base of the runners from the shelf supports. Then unhook the runner from the top rung of the shelf support and remove (Fig. 2.18).

To refit the glide-out runners

Hook the rear of the runner over the top rung of a pair of shelf supports. Then hook the front of the runner onto the same rung. Push to clip under the bottom rung (Fig. 2.19).

Ensure that the shelf runners are fitted in the same position on each side (Fig. 2.20).

The front of the shelf runners can be identified by the bracket (Fig. 2.17).

⚠ DO NOT put the glide-out shelf runners in a dishwasher.

The Handyrack (Optional extra)

The Handyrack (Fig. 2.21) fits to the left-hand oven door only. Food cooking on it is easy to attend to, because it is accessible when the door is open.

The maximum weight that can be held by the Handyrack is 5.5 kg (12 lb). It should only be used with the supplied roasting tin, which is designed to fit the Handyrack. Any other vessel could be unstable.

It can be fitted at two different heights. One of the oven shelves must be removed and the other positioned to suit.

When the Handyrack is used in its highest position, other dishes can be cooked on the bottom shelf position or base of the oven.

When the Handyrack is used in its lowest position, other dishes can be cooked on the second shelf position or base of the oven.

To fit the Handyrack, locate one side of it on the door bracket (Fig. 2.22).

Then spring the other side out to clip it onto the other bracket (Fig. 2.23).

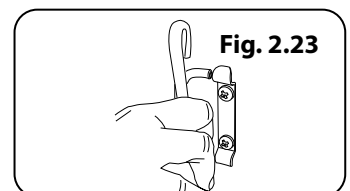
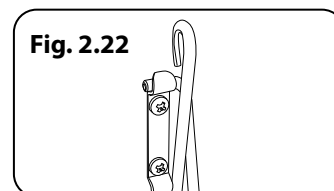
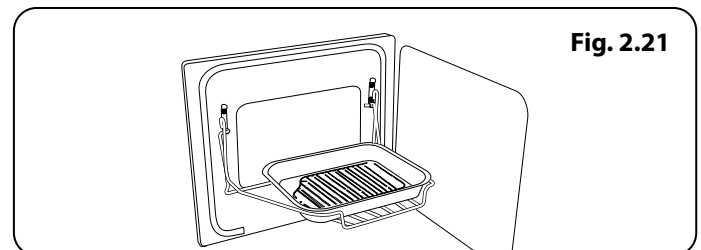
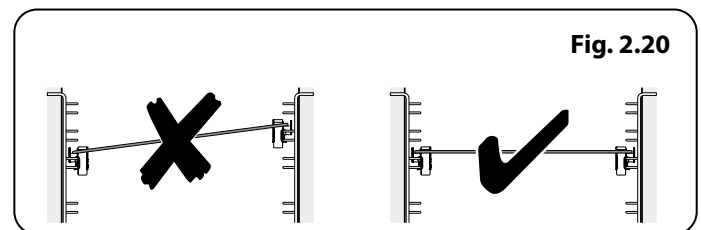
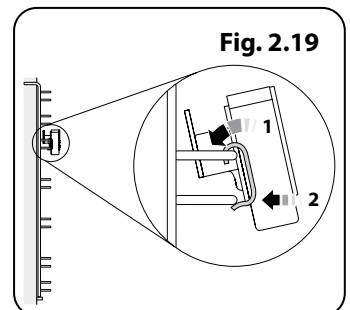
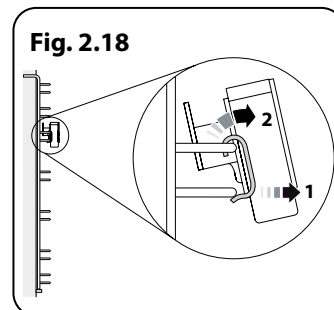
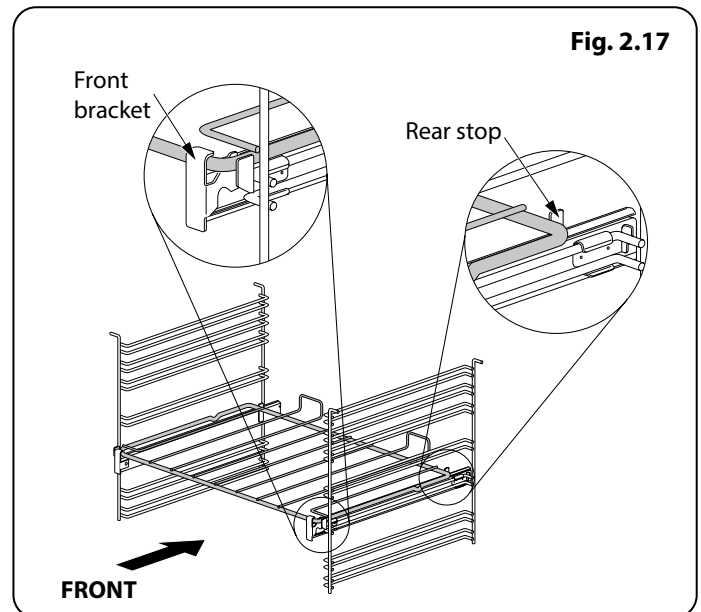

3. Using the Glide-out Grill™

Fig. 3.1

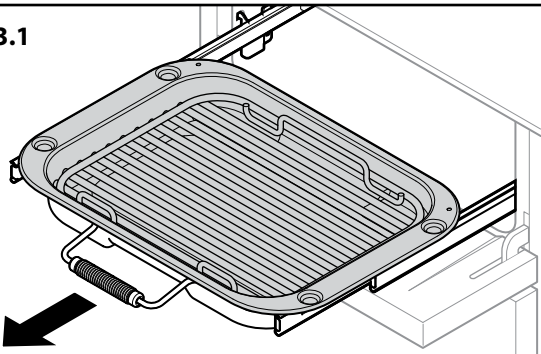
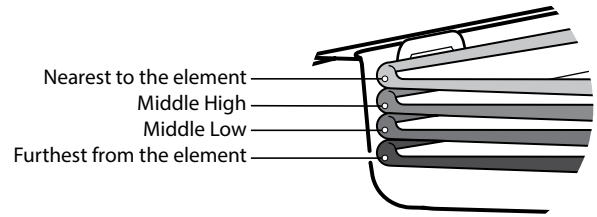
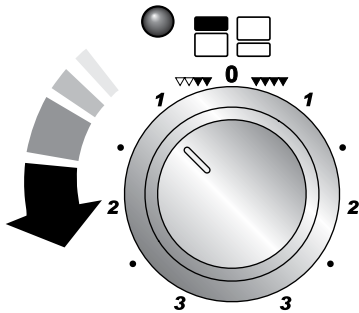

Fig. 3.2



Four grill height positions refer to Fig. 3.5

Fig. 3.3



To switch on the right half element

Fig. 3.4

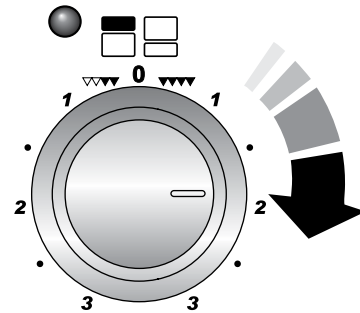

To switch on both elements

Four grill height positions

Fig. 3.5

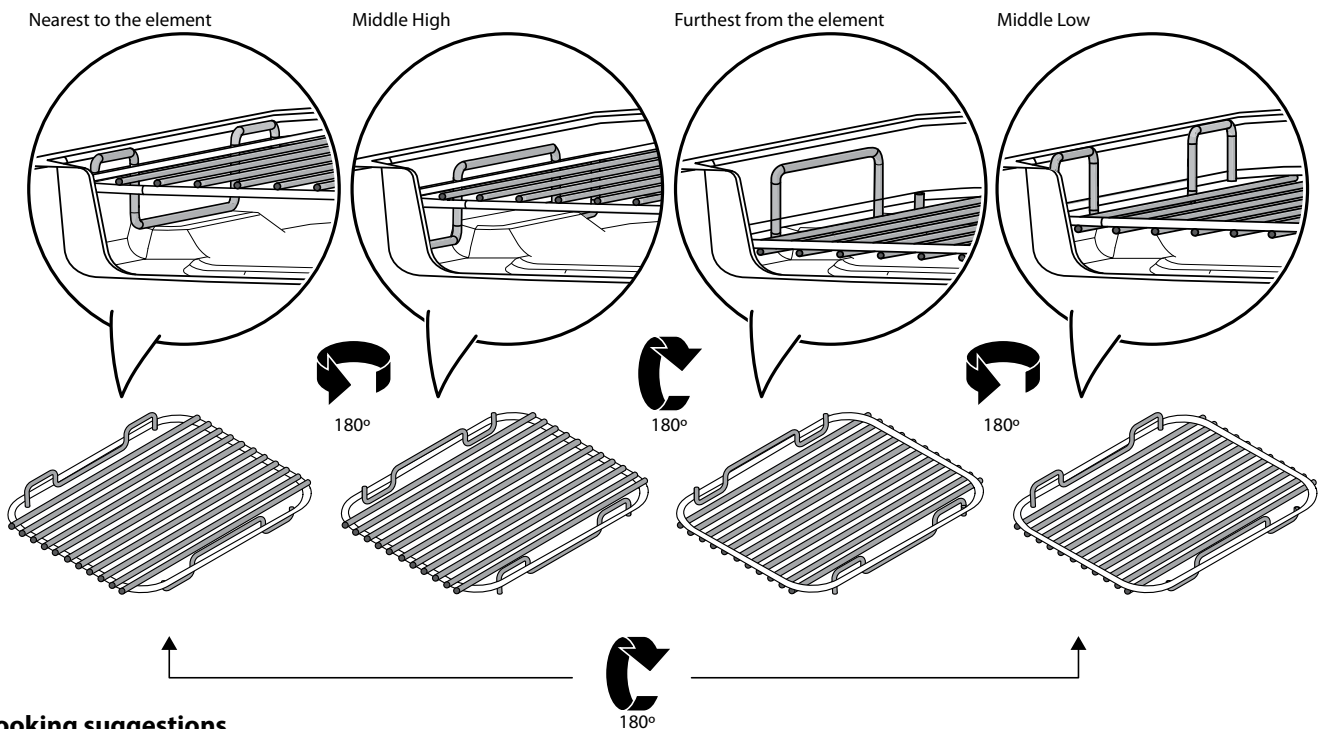

Cooking suggestions

1. Nearest to the element – Toast, streaky bacon.
2. Middle high – cheese on toast, welsh rarebit, courgette slices, back bacon.
3. Middle low – fish fillets, vegetable skewers.
4. Furthest from the element – whole fish, thick pork chops, chicken breasts, chicken or beef skewers.

NOTE: A short term cooking process has to be supervised continuously.

4. The Multifunction Oven

The clock must be set to the time of day before the oven will work. See the section on 'The Clock' for instructions on setting the time of day.

References to 'left-hand' and 'right-hand' ovens apply as viewed from the front of the appliance.

The left-hand oven is a multifunction oven, while the right-hand is a steam cavity.

The Multifunction Oven (left-hand)

As well as the oven fan and fan element, multifunction ovens are fitted with two extra heating elements, one visible in the top of the oven and the second under the oven base. Take care to avoid touching the top element and element deflector when placing or removing items from the ovens.

Table 4.1 gives a summary of the multifunction modes.

The multifunction oven has many varied uses. We suggest you keep a careful eye on your cooking until you are familiar with each function. Remember, not all functions will be suitable for all food types.

Operating the Multifunction Oven

Fig. 4.1 shows the left hand, touch sensitive control panel, for the multifunction oven.

To select a cooking function

Touch and hold the "Standby" button (1). The display will show the fan oven mode and a temperature setting of 180°C. The oven will start cooking in this mode after 5 seconds.

The oven light will turn on for 2 minutes and then go off. The oven light can be turned off at any time by tapping button (4).

To change the cooking function touch and hold the "Mode" button (2) until the cooking symbol begins to flash.

Change the cooking function using the [+] or [-] buttons (5 or 6). The oven will start cooking after 5 seconds.

Note: Cycling through the oven functions will re-set the oven temperature to the default 180°C.

To adjust cooking temperature

Touch and hold the "Temperature" button (3) until the display begins to flash.

Select your desired temperature using the [+] or [-] buttons (5 or 6). The oven will start to cook at the new temperature after 5 seconds.

If a lower cooking temperature is chosen there will be a time period required for the cavity to cool down.

Note: Tap the "Temperature" button during cooking to display the current temperature in the oven cavity.

To turn the Multifunction oven off

The multifunction oven is turned off by tapping the "Standby/On" button (1).









| Symbol | Function | Use |
|---|-----------------|---|
|  | Fan | A full cooking function, even heat throughout, great for baking |
|  | Duo | Gentle form of heating using base heat and fan. Suitable for pastries, cakes and open tarts, for example, quiches |
|  | Conventional | A full cooking function for roasting and baking in the lower half of the oven |
|  | Base heat | To crisp up the bases of quiche, pizza or pastry |
|  | Grill | This function radiates the heat from the grill element |
|  | Fanned grilling | Grilling meat and fish with the door closed |
|  | Fan assisted | A full cooking function good for roasting and baking |
|  | Delicate | To cook delicate items; creme brulee, blind baking, bain marie |
| ECO | ECO mode | Energy saving function for foods requiring 45 minutes or less |
|  | Defrost | To thaw small items in the oven without heat |

Table 4.1

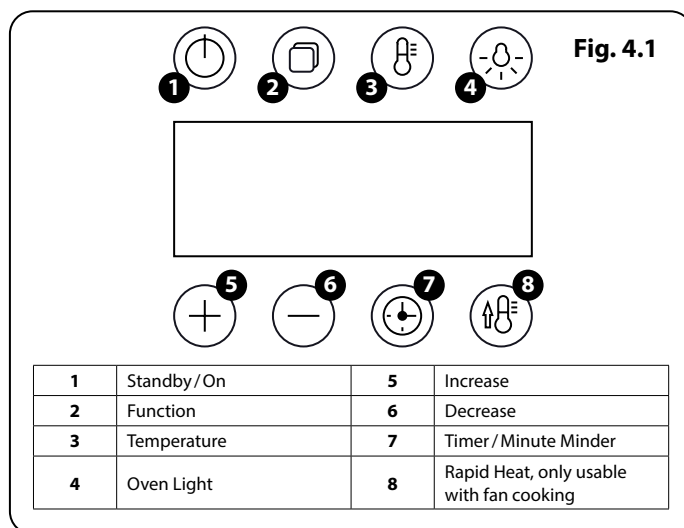
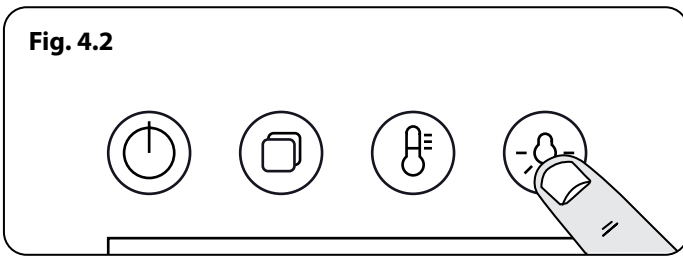

Fig. 4.2



ECO Mode

This setting saves energy, cooking in fanned mode, for foods requiring a cooking time of 45 minutes or less. No preheating .

Note: The oven door must remain closed during ECO mode. Failure to do so will result in the oven continuing to cook after the pre-set 45 minutes.

The following foods are recommended for the ECO setting:

- Ready prepared meals - meals should have the maximum duration of 45 minutes from chilled, and must not be frozen.
- Cookies, brownies and similar non-yeast baked food.

We always recommend that any food is checked to ensure it is fully cooked through. If in doubt please allow extra time.

Rapid Heat

The "Rapid Heat" setting (**8**) enables you to preheat the oven faster than normal. It uses the fan oven element with additional heat from one of the elements in the top of the oven.

When the oven cavity has reached the set temperature an alarm will sound, the rapid heat cycle will end and the selected cook mode will be activated.

Rapid heat mode can only be activated when the Fan function is selected.

Oven Lights

Tap the button to turn the oven light on (**Fig. 4.2**).

If the oven light fails, turn off the power supply before changing the bulb. See the *'Troubleshooting'* section for details on how to change the bulb.

Display Lock

To lock the display touch and hold the [+] and [-] buttons simultaneously. This will prevent the buttons being used. The lock symbol [] will be displayed.

To unlock the display touch and hold the [+] and [-] buttons again. The lock symbol will go out.

Accessories

Glide-out Oven Shelves

The left-hand oven is supplied with 2 glide-out oven shelves.

To fit the glide-out shelf, hook the front of the shelf onto the runners as shown (Fig. 4.3). The rear of the shelf should rest on the runners, in front of the rear stop (Fig. 4.3).

The glide-out shelf and runners can be easily removed or repositioned.

To remove the glide-out shelf

Raise the rear of the shelf, so that it clears the rear stops. Then unhook from the front locating bracket.

To remove the glide-out runners

Twist to unclip the base of the runners from the shelf supports. Then unhook the runner from the top rung of the shelf support and remove (Fig. 4.4).

To refit the glide-out runners

Hook the rear of the runner over the top rung of a pair of shelf supports. Then hook the front of the runner onto the same rung. Push to clip under the bottom rung (Fig. 4.5).

Ensure that the shelf runners are fitted in the same position on each side (Fig. 4.6).

The front of the shelf runners can be identified by the bracket (Fig. 4.3).

⚠ DO NOT put the glide-out shelf runners in a dishwasher.

Steam cavity Shelves

The steam cavity shelves (Fig. 4.7) are retained when pulled forward but can be easily removed and refitted.

Pull the shelf forward until the back of the shelf is stopped by the shelf stop bumps in the oven sides (Fig. 4.8).

Lift up the front of the shelf so the back of the shelf will pass under the shelf stop and then pull the shelf forward (Fig. 4.9).

To refit the shelf, line up the shelf with a groove in the oven ladders and push the shelf back until the ends hit the shelf stop. Lift up the front so the shelf ends clear the shelf stops, and then lower the front so that the shelf is level and push it fully back (Fig. 4.10).

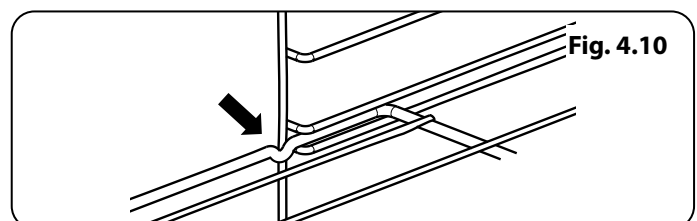
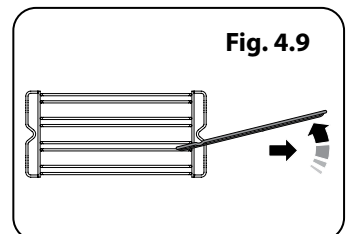
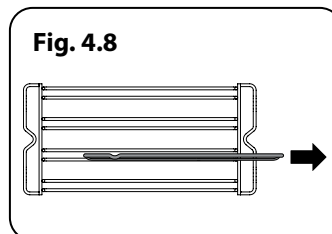
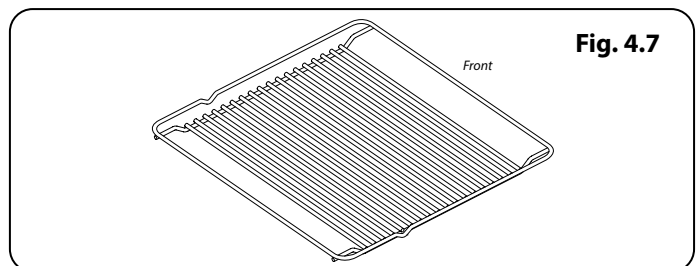
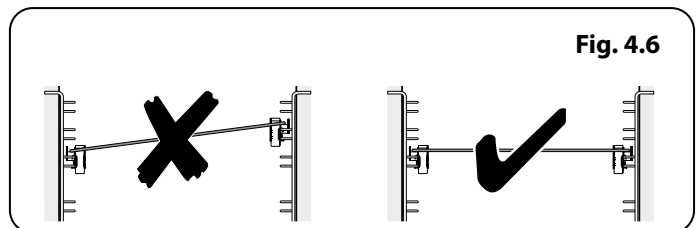
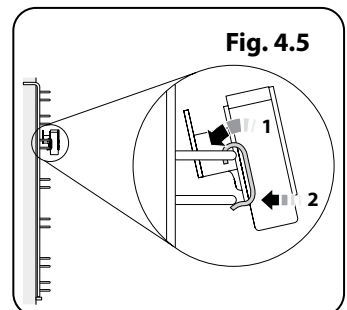
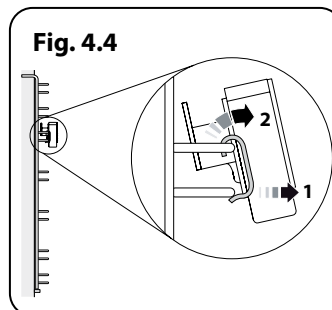
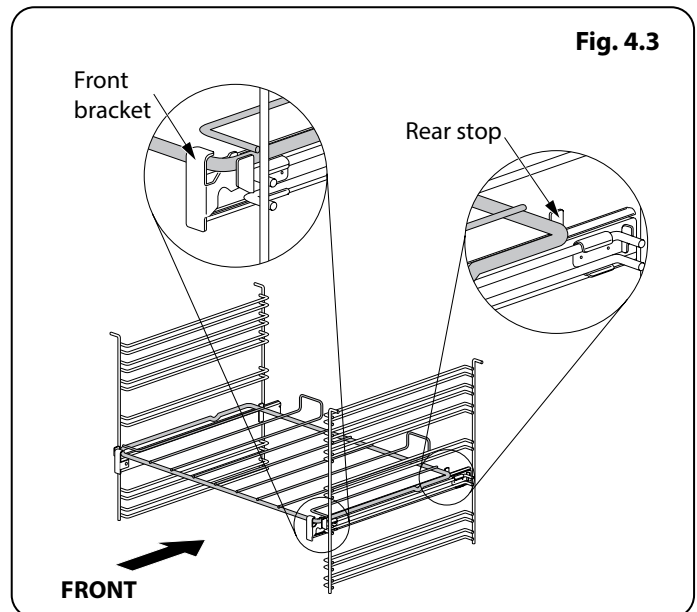

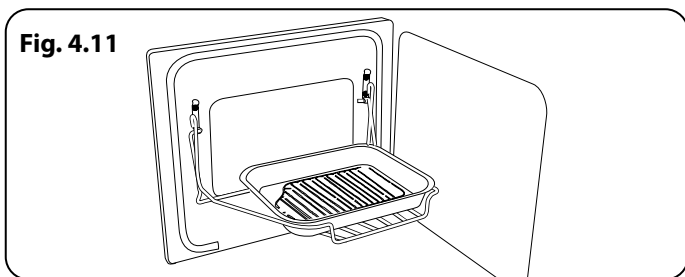

Fig. 4.11

The Handyrack (Optional extra)

The Handyrack (**Fig. 4.11**) fits to the left-hand oven door only. Food cooking on it is easy to attend to, because it is accessible when the door is open.

The maximum weight that can be held by the Handyrack is 5.5 kg (12 lb). It should only be used with the supplied roasting tin, which is designed to fit the Handyrack. Any other vessel could be unstable.

It can be fitted at two different heights. One of the oven shelves must be removed and the other positioned to suit.

When the Handyrack is used in its highest position, other dishes can be cooked on the bottom shelf position or base of the oven.

When the Handyrack is used in its lowest position, other dishes can be cooked on the second shelf position or base of the oven.

To fit the Handyrack, locate one side of it on the door bracket (**Fig. 4.12**).

Then spring the other side out to clip it onto the other bracket (**Fig. 4.13**).

The Clock / Timer

The clock must be set to the time of day before the multi-function oven or steam cavity will work.

Setting the clock

1. Once the cooker is connected and switched on, the hours in the display will flash (**Fig. 4.14**).
2. Whilst the hours are flashing tap either the [+] or [-] buttons to set the hour.
3. Tap the 'timer' button and the minutes will flash. Use the [+] or [-] buttons to set the minutes (**Fig. 4.15**).

To re-set the time, touch and hold the 'timer' button until the hours begin to flash then repeat the procedure described above using the [+] or [-] buttons.

Note: If no button is tapped, the current time will be saved by the clock, after 5 seconds.

Setting the minute minder

The minute minder can be set as a reminder when the main oven is on or off.

The minute minder provides the ability to set a countdown from 00:01h to 23:59h, at the end of which an alarm will sound. The timer shows *hours:minutes*.

1. Tap the timer button once to enter the minute minder (**Fig. 4.16**).
2. The hours will start to flash. Set the hours using the [+] or [-] buttons (**Fig. 4.16**).
3. Tap the timer button again, the minutes will flash. Set the minutes using the [+] or [-] buttons. The countdown will automatically begin after 3 seconds and the [⏰] symbol will show in the display.

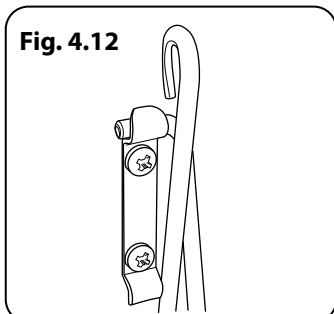

Fig. 4.12

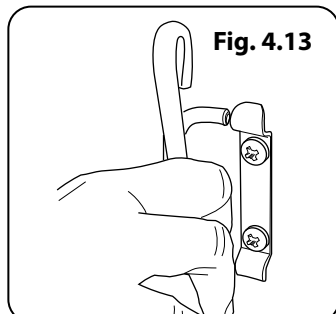

Fig. 4.13

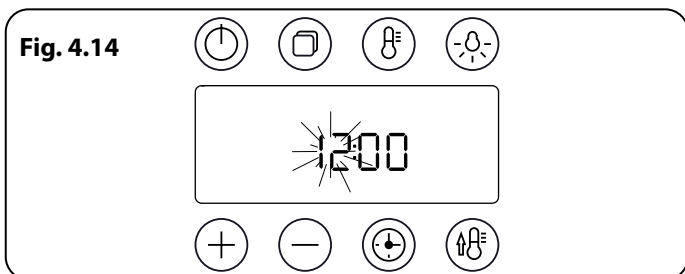

Fig. 4.14

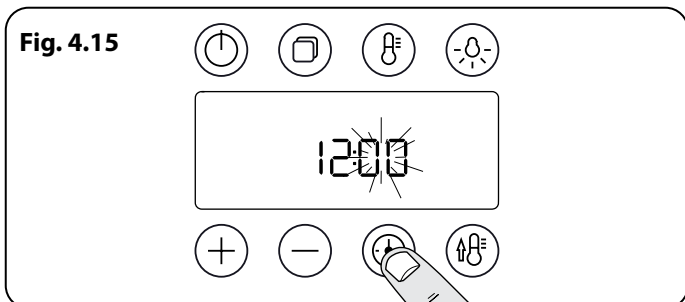

Fig. 4.15

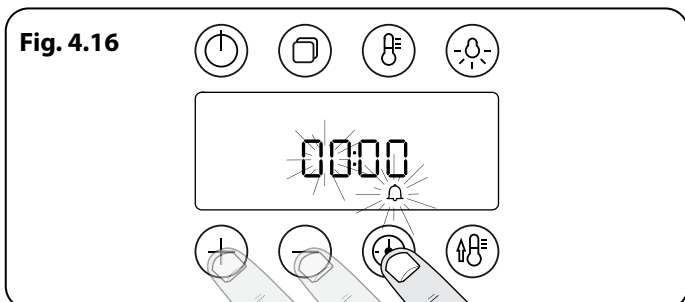

Fig. 4.16

- Once the specified time has elapsed an alarm will sound. It will stop automatically after 10 seconds.
- To cancel the minute minder, and enter a new time, tap the clock button whilst the [⌚] symbol is active.

To stop the multifunction oven after a specific time

- Set the cooking function and temperature (see "Operating the Multifunction Oven" on page 17).
- Touch and hold the 'timer' button until the cook period symbol [⌚] is displayed (Fig. 4.17). Set the hours using the [+] or [-] buttons.
- Tap the timer button again to set the minutes using the [+] or [-] buttons. Cooking will automatically start after 5 seconds and the remaining cook period will be displayed.
- At the end of the cooking period an alarm will sound and the oven will stop cooking. 'End' will show in the display. Remove the cooked food from the oven and close the oven door.
- If the alarm is not stopped it will repeat twice before stopping automatically.

To start and then stop the multifunction oven

Set the multifunction oven to automatically start and stop using a combination of the 'cook period' and 'stop time'.

You cannot set a start time directly – this is set automatically by a combination of the 'cook period' and 'stop time'.

- Set the cooking function and temperature (see "Operating the Multifunction Oven" on page 17).
- Touch and hold the 'timer' button until the cook period symbol [⌚] is displayed. Set the hours using the [+] or [-] buttons. Tap the timer button again to set the minutes using the [+] or [-] buttons (Fig. 4.17).
- Tap the 'timer' button to select the 'stop time' [→]. Set the the time you would like to stop cooking using the [+] or [-] buttons. Tap the 'timer' button again to set the minutes using the [+] or [-] buttons.
- The oven will enter Standby Mode after 3 seconds, the display will show the 'cook period' (Fig. 4.18) and the 'stop time' (Fig. 4.19). Changing the cooking function will clear the selection.
- When the 'stop time' is reached an alarm will sound and the oven will stop cooking. 'End' will show in the display. Remove the cooked food from the oven and close the oven door.
- If the alarm is not stopped it will repeat twice before stopping automatically.

Note: Fig. 4.18 and Fig. 4.19 show conventional heat function for illustration. All other modes are available.

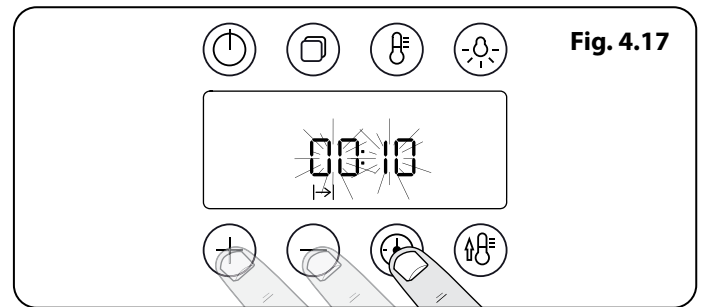

Fig. 4.17

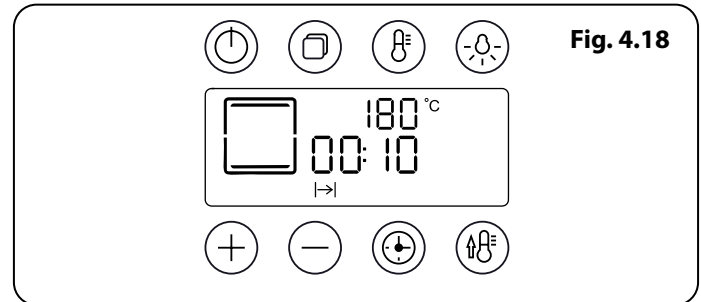

Fig. 4.18

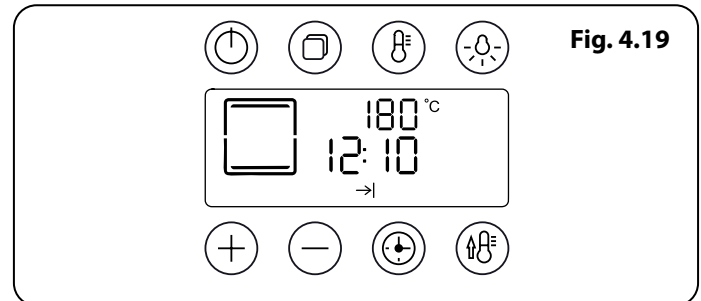

Fig. 4.19

Cooking Tips

Tips on cooking with the timer

If you want to cook more than one dish, choose dishes that require approximately the same cooking time. However, dishes can be 'slowed down' slightly by using small containers and covering them with aluminium foil, or 'speeded up' slightly by cooking smaller quantities or placing them in larger containers.

Very perishable foods such as pork or fish should be avoided if a long delay period is planned, especially in hot weather.

⚠ DO NOT place warm food in the oven to be timed.

⚠ DO NOT use a timed oven that is already warm.

⚠ DO NOT use the timed oven if the adjoining oven is already warm.

Whole poultry must be thoroughly defrosted before being placed in the oven. Check that meat and poultry are fully cooked before serving.

General oven tips

The wire shelves should always be pushed firmly to the back of the oven.

Baking trays with food cooking on them should be placed level with the front edge of the oven's wire shelves. Other containers should be placed centrally. Keep all trays and containers away from the back of the oven, as overbrowning of the food may occur.

For even browning, the maximum recommended size of a baking tray are:

- depth: 340 mm (13 ⅜") by width: 340 mm (13 ⅜") in the main oven

When the oven is on, DO NOT leave the door open for longer than necessary, otherwise the knobs may get very hot.

- Always leave a "finger's width" between dishes on the same shelf. This allows the heat to circulate freely around them.
- To reduce fat splashing when you add vegetables to hot fat around a roast, dry them thoroughly or brush lightly with cooking oil.
- Where dishes may boil and spill over during cooking, place them on a baking tray.
- The 'Cook & Clean' oven liners (see 'Cleaning Your Cooker') work better when fat splashes are avoided. Cover meat when cooking.
- Sufficient heat rises out of the oven while cooking to warm plates in the grill compartment.
- If you want to brown the base of a pastry dish, preheat the baking tray for 15 minutes before placing the dish in the centre of the tray.

Cooking Table

The oven control settings and cooking times given in the table below are intended to be used **as a guide only**. Individual tastes may require the temperature to be altered to provide a preferred result.

Food is cooked at lower temperature in a fan oven than in a conventional oven. When using recipes, reduce the fan oven temperature by 10°C and the cooking time by 5-10 minutes. The temperature in the fan oven does not vary with height in the oven so you can use any shelf.

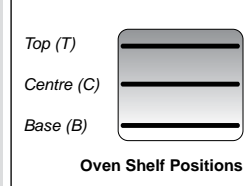

| Food | Conventional Oven °C (Shelf Position) | Fan Oven Temperature | Approximate Cooking Time | |
|--|---------------------------------------|----------------------|---|---|
| Meat | | | | |
| Beef (no bone) | 160 (C) | 150 °C | 30-35 minutes per 500g +30-35 minutes. | Thoroughly thaw frozen joints before cooking. Meat may be roasted at 220°C (210°C for fan oven) and the cooking time adjusted accordingly. For stuffed and rolled meats, add approximately 10 minutes per 500g, or cook at 200°C (190°C) for 20 minutes then 160°C (150°C) for the remainder. |
| | 200 (C) | 190 °C | 20-25 minutes per 500g +20-25 minutes. | |
| Lamb | 160 (C) | 150 °C | 30-35 minutes per 500g +30-35 minutes. | |
| | 200 (C) | 190 °C | 25-30 minutes per 500g +25-30 minutes. | |
| Pork | 160 (C) | 150 °C | 35-40 minutes per 500g +35-40 minutes. | |
| | 200 (C) | 190 °C | 25-30 minutes per 500g +25-30 minutes. | |
| Poultry | | | | |
| Chicken | 160 (C) | 150 °C | 20-25 minutes per 500g +20-25 minutes. | For stuffed poultry, you could cook at 200°C (190°C) for 20 minutes then 160°C (150°C) for remainder. Do not forget to include the weight of the stuffing. |
| | 200 (C) | 190 °C | 15-20 minutes per 500g +15-20 minutes. | |
| Turkey | 160 (C) | 150 °C | 20 minutes per 500g +20 minutes. | |
| | 200 (C) | 190 °C | 15 minutes per 500g +15 minutes. | |
| Duck | 160 (C) | 150 °C | 25-30 minutes per 500g. | For fresh or frozen prepacked poultry, follow instructions on the pack. Thoroughly thaw frozen poultry before cooking. |
| | 200 (C) | 190 °C | 20 minutes per 500g. | |
| Casserole | 140-150 (C) | 130 °C-140 °C | 2-4 hours according to recipe. | |
| Yorkshire Pudding | 220 (C) | 210 °C | Large tins 30-35 minutes; individual 10-20 minutes. | |
| Cake | | | | |
| Very rich fruit - Christmas, wedding, etc. | 140 (C/B) | 130 °C | 45-50 minutes per 500g of mixture. | Using the conventional oven: when two tier cooking leave at least one runner space between shelves. |
| Fruit 180 mm tin | 150 (C/B) | 140 °C | 2-2½ hours. | |
| Fruit 230 mm tin | 150 (C/B) | 140 °C | Up to 3½ hours. | |
| Madeira 180 mm | 160 (C/B) | 150 °C | 80-90 minutes. | Position the baking tray with the front edge along the front of the oven shelf. |
| Queen cakes | 190 (C/B) | 180 °C | 15-25 minutes. | |
| Scones | 220 (C/B) | 210 °C | 10-15 minutes. | Up to three tiers can be cooked in a fan oven at the same time but make sure to leave at least one runner space between each shelf being cooked on. |
| Victoria sandwich | | | | |
| 180 mm tin | 180 (C/B) | 170 °C | 20-30 minutes. | |
| 210 mm tin | 180 (C/B) | 170 °C | 30-40 minutes. | |
| Desserts | | | | |
| Shortcrust tarts | 200 (C/B) | 190 °C | 20-30 minutes on a preheated tray. | Up to three tiers can be cooked in a fan oven at the same time but make sure to leave at least one runner space between each shelf being cooked on. |
| Fruit pies | 200 (C/B) | 190 °C | 35-45 minutes. | |
| Tartlets | 200 (C/B) | 190 °C | 10-20 minutes according to size. | |
| Puff pastry | 210 (C/B) | 200 °C | 20-40 minutes according to size. | |
| Meringues | 100 (C/B) | 90 °C | 2-3 hours. | |
| Baked egg custard | 160 (C/B) | 150 °C | 45-60 minutes. | |
| Baked sponge pudding | 180 (C/B) | 170 °C | 40-45 minutes. | |
| Milk pudding | 140-150 (C/B) | 130 °C-140 °C | 2 to 3 hours. | |
| Bread | 210 (C) | 200 °C | 20-30 minutes. | |
| Fish | | | | |
| | Fanned Grilling | | | |
| Fillet | 190 (C/B) | 190 °C (C/B) | 15-20 minutes | |
| Whole | 190 (C/B) | 190 °C (C/B) | 15-20 minutes per 500g. | |
| Steak | 190 (C/B) | 190 °C (C/B) | Steaks according to thickness. | |

5. The Steam Cavity

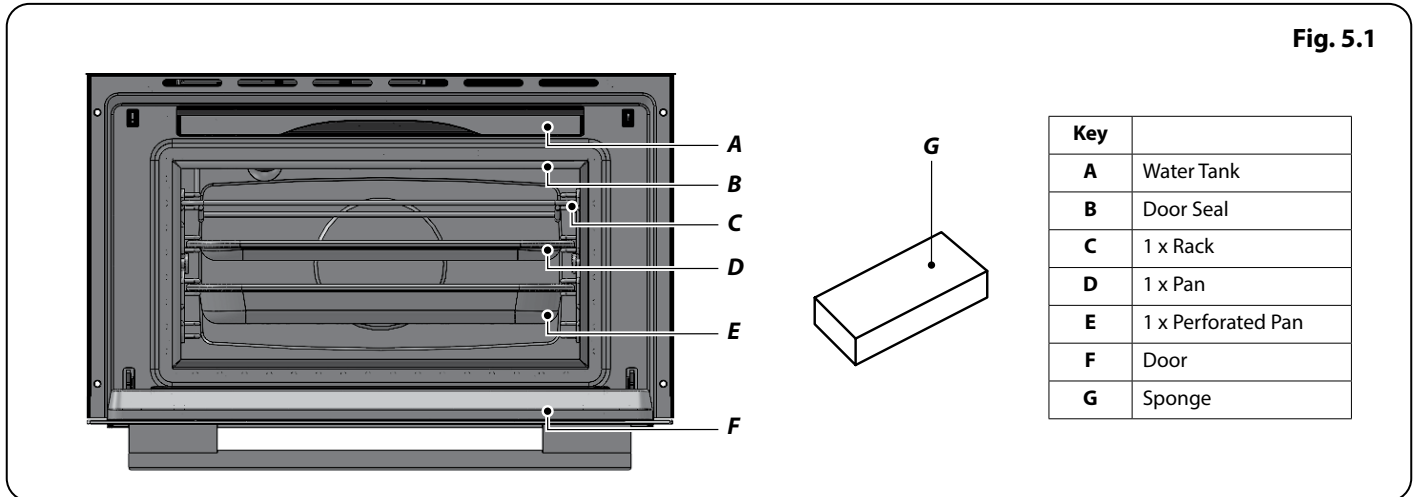

The Steam Cavity (right-hand)

The steam cavity is shown in **Fig. 5.1**.

Fig. 5.2 shows the touch sensitive control panel for the steam cavity.

Water Level

To fill the water tank or check the water level lift and pull the water tank from the oven cavity (**Fig. 5.1**).

Lift the lid and carefully fill from the tap or a small jug up to the maximum marker (**Fig. 5.3**). Wipe clean if the water overflows.

The clock, on the **left hand** oven, must be set to the time of day before the oven will work. See the section on **'The Clock/Timer'** for instructions on setting the time of day.

References to 'left-hand' and 'right-hand' ovens apply as viewed from the front of the appliance.

The left-hand oven is a multifunction oven, while the right-hand oven is a steam cavity.

Note: The time of day is not displayed on the steam cavity control.

Display Lock

To lock the display touch and hold the [+] and [-] buttons simultaneously. This will prevent the buttons being used. The lock symbol  will be displayed.

To unlock the display touch and hold the [+] and [-] buttons again.

Hygiene

Please remember to:

- Change the water in the tank before use. The display will remind you (**Fig. 5.9**).
- Clean the steam cavity after every cook cycle.

 The base of the steam cavity will remain HOT after use. Take extra care when cleaning.

- Observe the descaling interval.

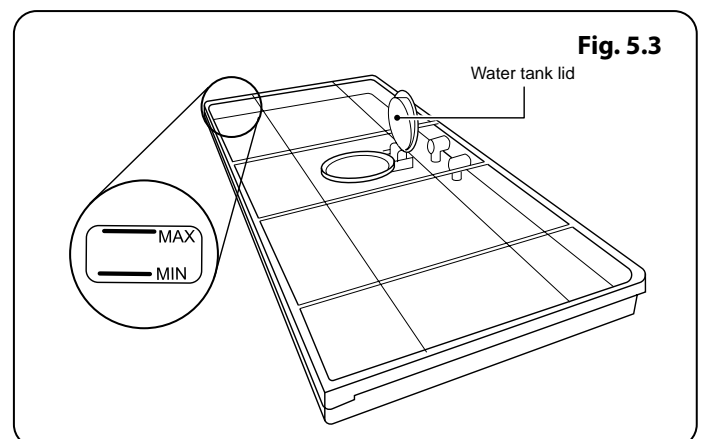
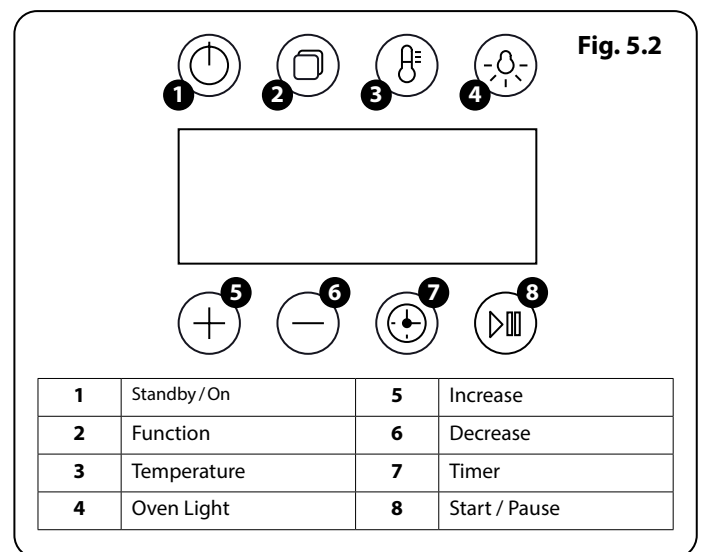

Operating the Steam Cavity

Note: The steam cavity may start a pump out cycle (**Fig. 5.12**) when first turned on. This is normal and it should be allowed to complete. The cycle will take approximately 2 minutes.

1. Touch and hold the standby button to switch the steam cavity on (**Fig. 5.4**). The display will show the maximum temperature; 100 °C, a 15 minute cook time and the steam icon will flash (**Fig. 5.5**).
2. To adjust the temperature, touch and hold the temperature button (**Fig. 5.6**) and use the [+] or [-] buttons to adjust (**Fig. 5.7**).
3. To adjust the cook period, tap the timer button once, to adjust the hours use the [+] or [-] buttons (**Fig. 5.8**). Tap the timer button again to adjust the minutes.
4. Tap the start / pause button. You will be advised to change the water in the tank (**Fig. 5.9**). See 'Water Level' on page 24. If you are already using fresh water touch start or wait to continue.

The appliance will begin to pump water, from the water tank, into the boiler (**Fig. 5.10**).

5. The oven cavity will begin to heat up to your set temperature. You can check the current temperature in the oven cavity by tapping the temperature button (**Fig. 5.6**).

When the oven has reached the pre-set temperature, the cook cycle will begin and the decimal points in the timer will flash.

Once cooking has completed, [END] will be displayed and 10 beeps will be emitted. This will be repeated twice. Also, the cavity light will turn on and the cooker fan will run for 2 minutes.

6. At the end of the cooking cycle the display will show *H2O HOT* (**Fig. 5.11**), this indicates the water in the boiler is hot and will be pumped back into the water tank once it has reached a pre-set temperature. When the water is being pumped out *H2O OUT* (**Fig. 5.12**) will be displayed.

Please allow the cycle to complete.

7. You can immediately re-use your steam cavity by tapping the [+] or [-] buttons.
8. The cooking cycle can be suspended at any time by tapping the pause button.

Note: It is normal for steam to be emitted from the steam cavity. This is not harmful.

Fig. 5.4

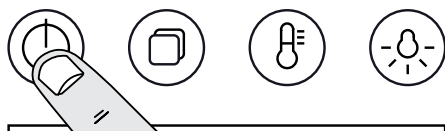

Fig. 5.5

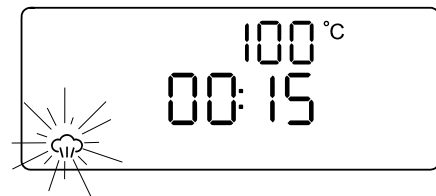

Fig. 5.6

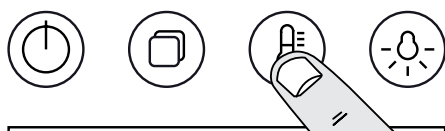

Fig. 5.7



Fig. 5.8

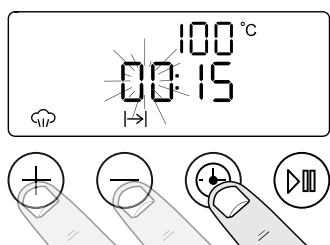

Fig. 5.9

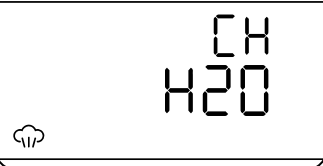

Fig. 5.10

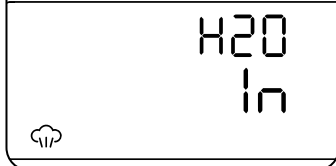

Fig. 5.11

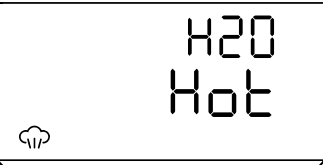
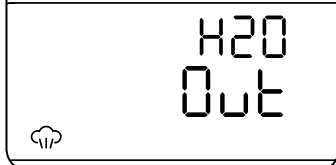

Fig. 5.12



Steam Cavity Functions

The steam cavity has three main functions:

steam 

grill 

descale 

Switch the oven on and tap the [+] or [-] buttons to scroll through these functions.

Using Grill Function in the Steam Oven Cavity

1. Touch and hold the standby button to switch the steam cavity on (**Fig. 5.13**) then use the [+] or [-] buttons to scroll through to the grill function (**Fig. 5.14**).
2. The default temperature is 180°C. To adjust the temperature, touch the temperature button then use the [+] or [-] buttons to adjust (**Fig. 5.15**). An audible beep will sound when the grill is up to temperature. The maximum temperature is 200°C and the minimum temperature is 40°C.
3. To adjust the cook period, tap the timer button once, to adjust the hours use the [+] or [-] buttons (**Fig. 5.16**). Tap the timer button again to adjust the minutes. The cook duration symbol [I→] will flash during this procedure.
4. A beeping sound will be heard once the grill has reached the set temperature.
5. To begin grilling tap the start/pause button (**Fig. 5.17**).

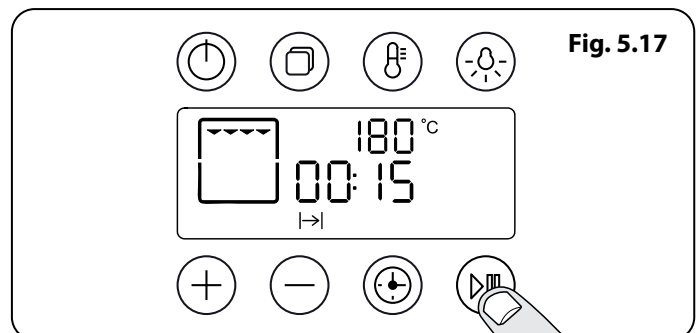
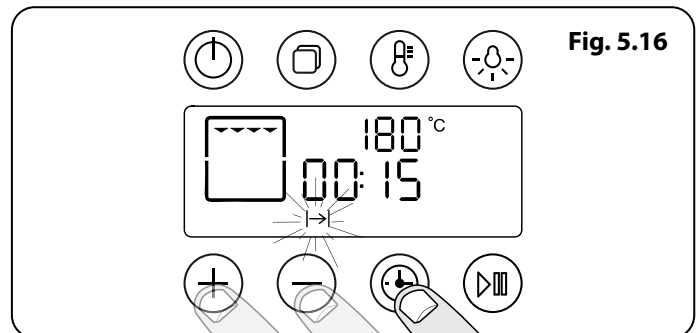
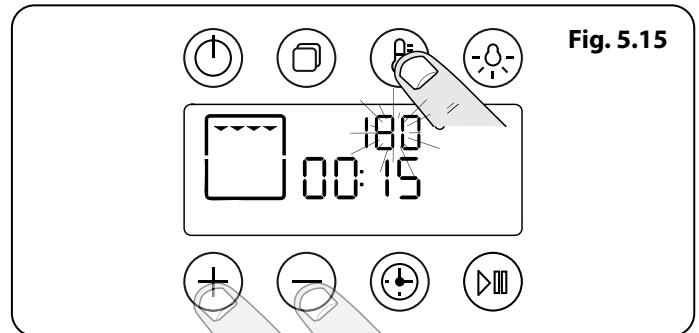
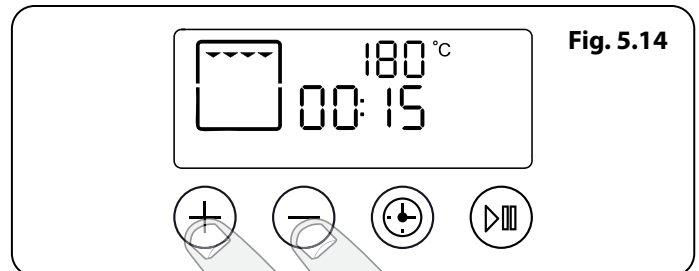
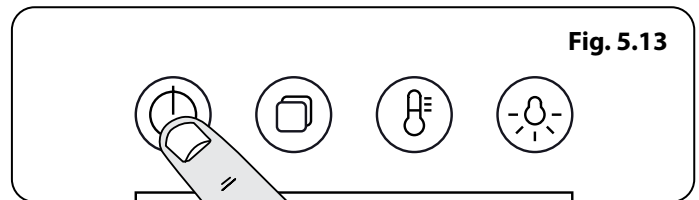

Program Modes

The steam cavity has pre-programmed modes for different food types.

To access these modes touch and hold the standby button to switch the steam cavity on.

Touch and hold the program button (**Fig. 5.13**). [**A1**] will show in the display. Scroll through the programs using the [+] or [-] buttons.

Touch and hold the program button again to access the next set of programs for fish. [**b1**] will be displayed.

Touch and hold the program button a third time to access the programs for meat. [**C1**] will be displayed.

See **Table 5.1** for an overview of the program functions.

| Vegetables | | | | | |
|------------|---|------------------|------------|------------|-------|
| Program | Type of vegetables | Temperature (°C) | Time (min) | Container | Level |
| A1 | Medium broccoli florets | 100 | 8 | Perforated | 2 |
| A2 | Carrot batons | 100 | 8 | Perforated | 2 |
| A3 | New potatoes | 100 | 18 | Perforated | 2 |
| A4 | Green beans | 100 | 6 | Perforated | 2 |
| A5 | Asparagus | 100 | 4 | Perforated | 2 |
| Fish | | | | | |
| Program | Type of fish | Temperature (°C) | Time (min) | Container | Level |
| b1 | 120g salmon fillet | 90 | 4 | Perforated | 2 |
| b2 | Raw tiger prawns | 90 | 5 | Perforated | 2 |
| b3 | Kippers | 100 | 6 | Perforated | 2 |
| b4 | Cod/Haddock Fillets | 100 | 8 | Perforated | 2 |
| b5 | Mussels | 90 | 8 | Perforated | 1/2 |
| Meat | | | | | |
| Program | Type of meat | Temperature (°C) | Time (min) | Container | Level |
| C1 | Meatballs | 100 | 8 | Solid | 2 |
| C2 | Turkey Escalope and chicken breasts | 100 | 10 | Solid | 2 |
| C3 | Bratwurst / hot dogs | 100 | 10 | Perforated | 2 |
| C4 | Large soft boiled egg(s) (at room temperature) | 100 | 6 | Perforated | 2 |
| C5 | Large hard-boiled egg(s) (at room temperature) | 100 | 10 | Perforated | 2 |

Items to be cooked should be spread evenly on the cooking trays.

Table 5.1

The Clock / Timer

The clock above the multi-function oven must be set to the time of day before the multi-function oven or steam cavity will work.

See "Setting the clock" on page 20.

Note: The steam cavity control does not show the time of day. This is automatically set from the multi-function oven control.

The display will remain blank until the steam cavity is turned on.

To stop the steam cavity at a specific time of day

1. Switch the cavity on and set the temperature (see 'Operating the Steam Cavity' on page 25).
2. Tap the timer button to set the 'cook period' hours using the [+] or [-] buttons. Tap the timer button again to set the minutes using the [+] or [-] buttons (**Fig. 5.18**).
3. Tap the Start / Pause button.

To start and then stop the steam cavity

Set the steam cavity to automatically start and stop using a combination of the 'cook period' and 'stop time'.

You cannot set a start time directly – this is set automatically by a combination of the 'cook period' and 'stop time'.

1. Switch the oven on and set the temperature (see 'Operating the Steam Cavity' on page 25).
2. Tap the 'timer' button, the cook period symbol [▶] is displayed. Set the hours using the [+] or [-] buttons. Tap the timer button again to set the minutes using the [+] or [-] buttons.
3. Tap the 'timer' button to select the 'stop time' [→]. Set the time you would like to stop cooking using the [+] or [-] buttons. Tap the 'timer' button again to set the minutes using the [+] or [-] buttons.
4. Tap the Start / Pause button. The display will show the 'cook period' (**Fig. 5.19**) and the 'stop time' (**Fig. 5.20**).
5. When the 'stop time' is reached an alarm will sound and the oven will stop cooking. 'End' will show in the display.

Tap the 'temperature' button during the cooking cycle to display the current oven temperature.

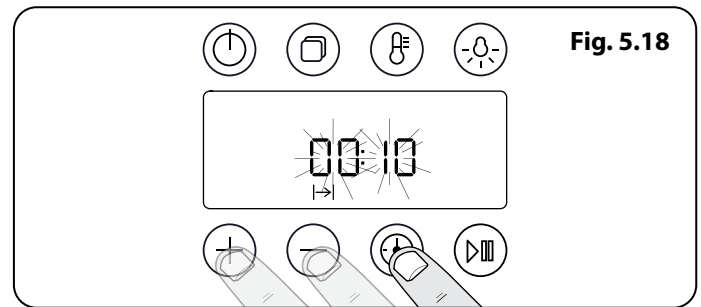

Fig. 5.18

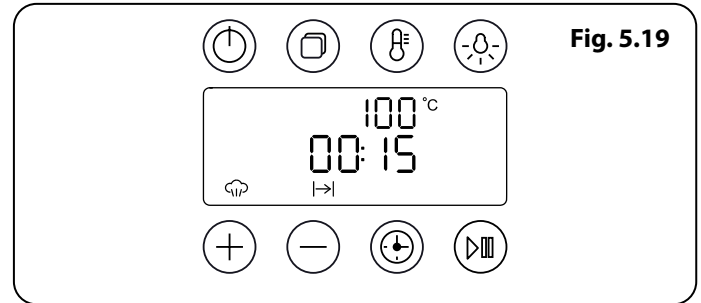

Fig. 5.19

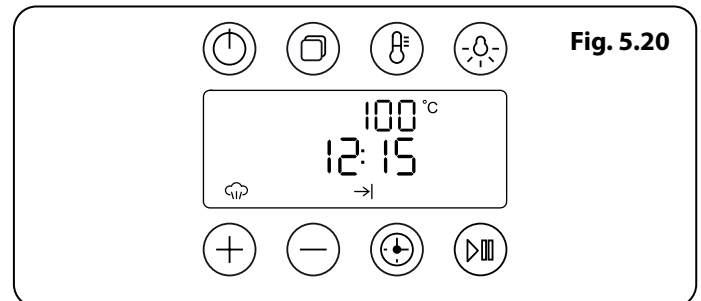

Fig. 5.20

6. Cleaning Your Cooker

Isolate the electricity supply before carrying out any major cleaning. Allow the cooker to cool.

⚠ NEVER use paint solvents, washing soda, caustic cleaners, biological powders, bleach, chlorine based bleach cleaners, coarse abrasives or salt.

⚠ DO NOT mix different cleaning products – they may react together with hazardous results.

All parts of the cooker can be cleaned with hot soapy water. Take care that no surplus water seeps into the appliance.

Remember to switch the electricity supply back on and reset the clock before reusing the cooker.

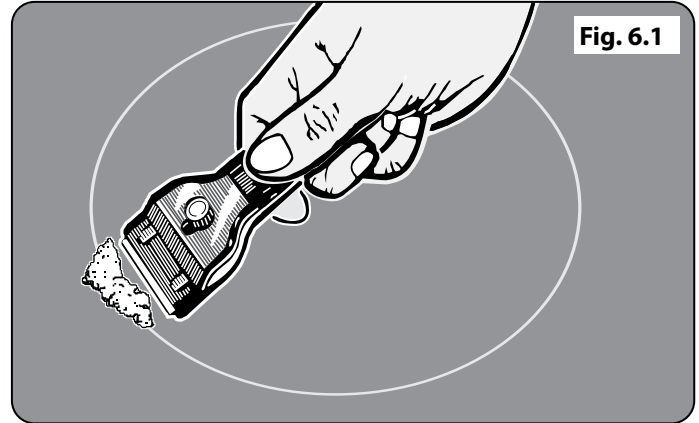

Hob

Daily Care

First of all make sure that all heat indicator lights are off and that the cooking surface is cool. Apply a small dab of ceramic cleaning cream in the centre of each area to be cleaned. Dampen a clean paper towel and work the cream onto the cooking surface. As a final step, wipe the cooking surface with a clean, dry paper towel.

Cleaning Spills

For spills and boil-overs that occur while cooking, turn the unit off and wipe the area surrounding the hot zone with a clean paper towel. If a spill (other than a sugary substance) is on the hot zone, do not clean until the unit has completely cooled down, and then follow the instructions below ('Cleaning Burned-on Spills').

If you accidentally melt anything on the surface, or if you spill foods with a high sugar content (preserves, tomato sauce, fruit juice, etc.), remove the spill IMMEDIATELY with a razor scraper, while the unit is still hot.

⚠ IMPORTANT: Use an oven glove to protect your hand from potential burns.

Scrape the major spill or melted material from the cooking zone and push into a cold area. Then, turn the unit OFF and allow it to cool before cleaning further. After the cooking surface cools down and the heat indicator lights go off, follow the 'Daily Care' procedure outlined above.

Cleaning Burned-on Spills

Make sure that the heat indicator lights are off and that the hob is cool. Remove the excess burned-on substance with a single-edged razor scraper. Hold the scraper at an angle of about 30° to the surface and then scrape off the burned-on matter (Fig. 6.1).

Once you have removed as much as possible with the scraper, follow the 'Daily Care' procedure outlined above.

Fig. 6.2

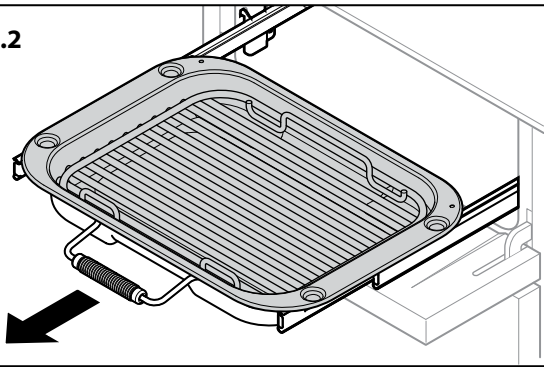

Fig. 6.3

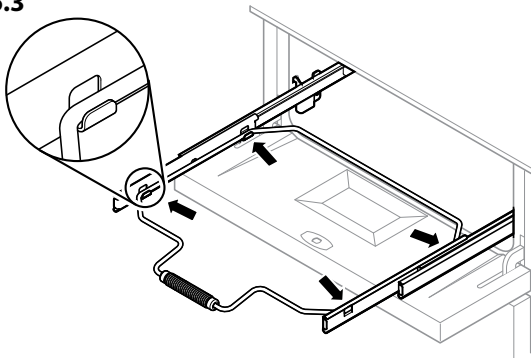

Fig. 6.4

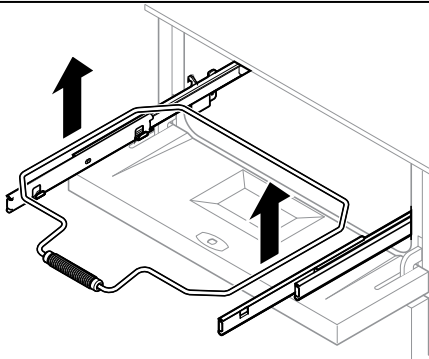
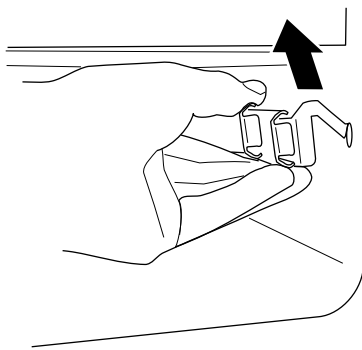

Fig. 6.5



Induction Griddle *(some models only)*

- ⚠ **NEVER** use paint solvents, washing soda, caustic cleaners, biological powders, bleach, chlorine based bleach cleaners, coarse abrasives or salt.
- ⚠ **DO NOT** mix different cleaning products – they may react together with hazardous results.
- ⚠ **DO NOT** put this griddle in a dishwasher.

Safety

- ⚠ Please always use potholders for cast-on handles because they tend to get hot, given their good heat conductivity.

Glide-out Grill™

The grill pan and trivet should be washed in hot soapy water. Alternatively, the grill pan can be washed in a dishwasher.

After grilling meats or any foods that soil, leave to soak for a few minutes immediately after use. Stubborn particles may be removed from the trivet using a nylon brush.

- ⚠ **Before you remove any of the grill parts for cleaning, make sure that they are cool, or use oven gloves.**
- ⚠ **DO NOT** use any abrasive substances.

Removing the Glide-out Grill Pan

The glide-out grill pan can be easily removed for cleaning as follows:

Remove the grill pan support frame by pulling the grill pan forward (**Fig. 6.2**).

Lift the grill pan clear of the support frame. The support frame is held to the side rails by two clips on each side (**Fig. 6.3**).

For each side, support the side rail with one hand and with the other hand lift the frame up and out of the side clips (**Fig. 6.4**).

For safety, push the side rails back into the grill chamber.

If you need to remove the side rails to allow cleaning of the grill chamber, you can unhook them from the grill chamber sides (**Fig. 6.5**) and wipe the sides clean with a soft cloth and mild detergent.

- ⚠ **DO NOT** put the side runners in a dishwasher.

Once you have finished, hook the side rails back onto the sides of the chamber. To refit the frame, pull the side rails forward and, for each side in turn, support the side rail and press the frame down into the side rails.

Control Panel and Doors

Avoid using any abrasive cleaners, including cream cleaners. For best results, use a liquid detergent.

The same cleaner can also be used on the doors. Alternatively, use a soft cloth wrung out in clean hot soapy water. You can use the same method for cleaning the control panel and knobs. After cleaning, polish with a dry cloth.

Glass Fronted Door Panels

The oven door front panels can be taken off so that the glass panels can be cleaned. Move the cooker forward to gain access to the sides (see the 'Moving the Cooker' section under 'Installation').

Open the oven door slightly and remove the front panel fixing screws from the door sides, two each side (**Fig. 6.6**). Carefully lift off the outer door panel. The inside face of the glass panels can now be cleaned – take care not to disturb or wet the door insulation.

Note: If the door is triple glazed then the inner two panels are fixed together and should not be separated. After cleaning, carefully refit the outer door panel and replace the side fixing screws.

⚠ DO NOT use harsh abrasive cleaners or sharp metal scrapers to clean the oven door glass since they can scratch the surface, which may result in shattering of the glass.

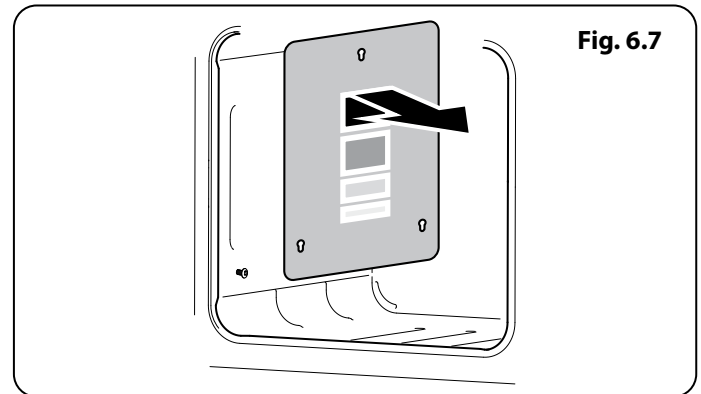
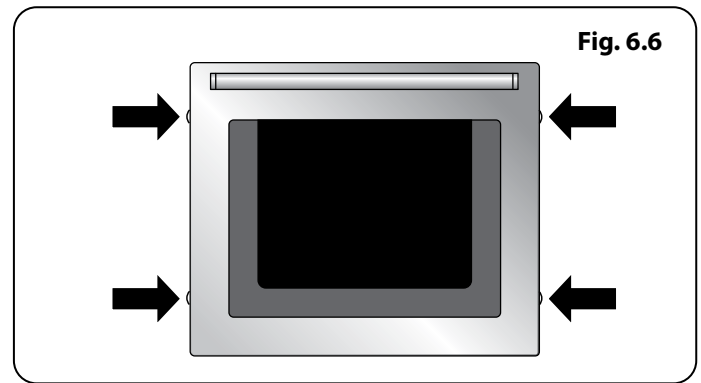

Multifunction Oven

'Cook & Clean' Panels

The main oven has side 'Cook & Clean' panels which have been coated with a special enamel that partly cleans itself. This does not stop all marks on the lining, but helps to reduce the amount of manual cleaning needed.

These panels work better above 200°C. If you do most of your cooking below this temperature, occasionally remove the panels and wipe with a lint free cloth and hot soapy water. The panels should then be dried and replaced and the oven heated at 200°C for about one hour. This will make sure that the panels are working effectively.

Removing the Panels to Clean the Enamel Interior

Some of the lining panels can be removed for cleaning.

If you wish to clean the enamel interior of the oven, you will need to remove the shelves before removing the 'Cook & Clean' panels. To remove the side panels, simply lift the panel and slide forwards. (**Fig. 6.7**).

Once the panels have been removed, the oven enamel interior can be cleaned.

⚠ DO NOT use steel wool, oven cleaning pads, or any other materials that will scratch the surface.

Refit in the reverse order.

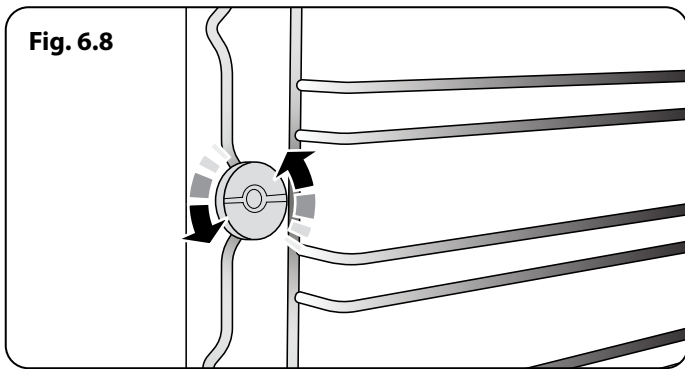

Fig. 6.8

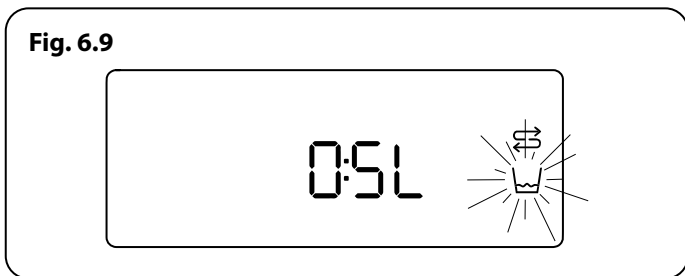

Fig. 6.9

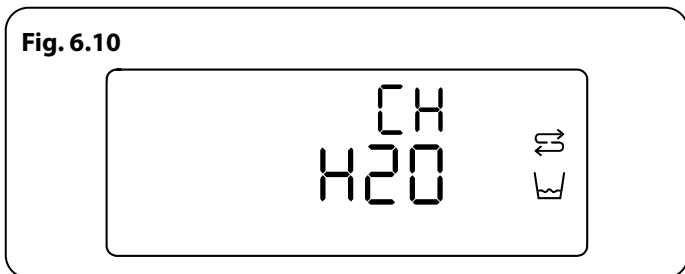
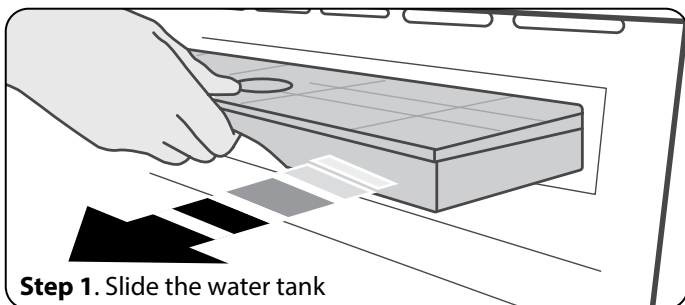
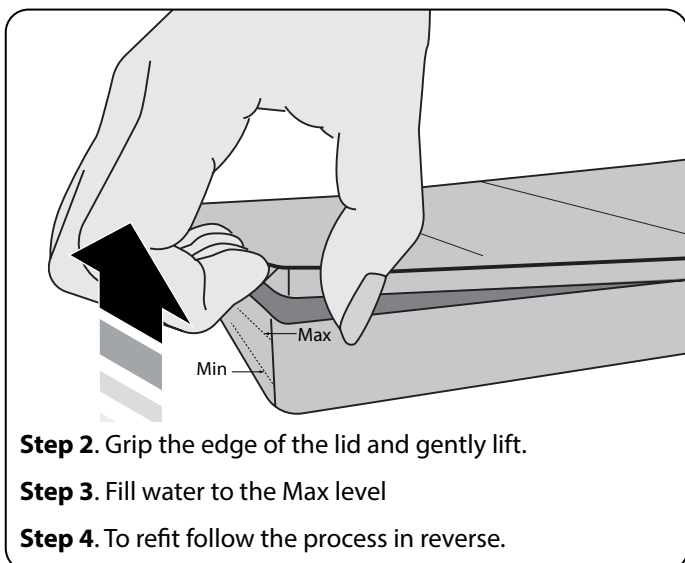

Fig. 6.10

Cleaning the water tank



Step 1. Slide the water tank



Step 2. Grip the edge of the lid and gently lift.

Step 3. Fill water to the Max level

Step 4. To refit follow the process in reverse.

Steam Cavity

⚠ Before cleaning your oven or performing maintenance, please switch off the power supply. In order to prolong the service life of steam cavity, please note the following points:

The enameled or stainless steel parts should be washed with lukewarm water without using any abrasive powders or corrosive substances which could scratch, stain and damage the oven. After cleaning, it is advisable to rinse thoroughly and dry.

The inside of the oven should preferably be cleaned immediately after use, when it is still warm, with hot water and soap. After cleaning, it is advisable to rinse thoroughly and dry.

⚠ The base of the steam cavity will remain HOT after use. Take extra care when cleaning.

To remove the ladders unscrew the retaining screws (**Fig. 6.8**)

Avoid using abrasive detergents (for example cleaning powders, etc) and abrasive sponges for dishes or acids (such as lime scale remover, etc) as these could damage the enamel. If the grease spots and dirt are particularly tough to remove, use a special product for oven cleaning, following the instructions provided on the packet.

Never use a steam cleaner for cleaning inside the oven.

Use a descale product which is suitable for descaling a coffee machine. Do not use a foam cleaner.

Avoid using grinding sand mold cleaner, such as wash mat, steel wire ball, etc, as this may damage the surface.

⚠ Important: please do not clean the water tank in the dishwasher.

Descal (manual)

Note: Once the descale cycle is started it cannot be stopped and has to complete (approx. 30 minutes).

Touch and hold the 'Standby' button to switch the display on, use the [+] or [-] buttons to select the descale function [☞].

Tap the 'Start / Pause' button to begin the descale cycle.

Fill the water tank with 0.5 litres of descaling solution (**Fig. 6.9**). Once the water tank is replaced the cycle will begin

The cycle will take 30 minutes to complete, at the end of which, you will be asked to change the water (**Fig. 6.10**) twice, whilst it is pumped through the boiler to remove the descaler solution.

Once completed the unit will beep and the display will show [End].

Descal (automatic)

After 48 hours of boiler use your steam oven will request a descale. Follow the instructions detailed above under "Descal (manual)".

Cleaning Table

Cleaners listed (**Table 6.1**) are available from supermarkets or electrical retailers as stated.

For enamelled surfaces use a cleaner that is approved for use on vitreous enamel.

Regular cleaning is recommended. For easier cleaning, wipe up any spillages immediately.

| Hotplate | | |
|---|---|--|
| Part | Finish | Recommended Cleaning Method |
| Hob top (including burner heads and caps) | Enamel, stainless steel, aluminium | Hot soapy water, soft cloth. Any stubborn stains remove gently with a nylon scourer. |
| Ceramic/Induction hob | Toughened glass | Hot soapy water; cream cleaner/scourer if necessary. |
| Griddle plate (some models only) | Non-stick surface | Allow to cool. Wash in hot soapy water. Do not use abrasive cleaners/scourers. |
| Warming zone (some models only) | Toughened glass | Hot soapy water, cream cleaner/scourer if necessary. |
| Outside of Cooker | | |
| Part | Finish | Recommended Cleaning Method |
| Door, door surround and storage drawer exterior | Enamel or paint | Hot soapy water, soft cloth. Any stubborn stains, remove gently with a liquid detergent. |
| | Stainless steel | E-cloth (electrical retailers) or microfibre all-purpose cloth (supermarket). |
| Sides and plinth | Painted surface | Hot soapy water, soft cloth. |
| Splashback/rear grille | Enamel or stainless steel | Hot soapy water, soft cloth. Cream cleaner, with care, if necessary. |
| Control panel | Paint, enamel or stainless steel | Warm soapy water. Do not use abrasive cleaners on lettering. |
| Control knobs/handles & trims | Plastic/chrome, copper or lacquered brass | Warm soapy water, soft cloth. |
| | Brass | Brass polish. |
| Oven door glass/glass lid (some models only) | Toughened glass | Hot soapy water, cream cleaner/scourer if necessary. |
| Oven and Grill | | |
| Part | Finish | Recommended Cleaning Method |
| Sides, floor & roof of oven NOT COOK & CLEAN OVEN PANELS (see below) | Enamel | Any proprietary oven cleaner that is suitable for enamel. CAUTION: CORROSIVE/CAUSTIC OVEN CLEANERS: FOLLOW MANUFACTURER'S INSTRUCTIONS. Do not allow contact with the oven elements. |
| Cook & Clean oven panels (some models only) | Special enamel that partly cleans itself | This surface cleans itself at 200 °C and above, or the panels can be removed and washed with hot soapy water and a nylon brush. |
| Oven shelves, Handyrack, Grill trivet, Handygrill rack (some models only) | Chrome | An oven interior cleaner that is suitable for chrome. Soap filled pad. Dishwasher. |
| Grill pan/meat tin (some models only) | Enamel | Hot soapy water. Soap filled pad. Dishwasher. |

Table 6.1

7. Troubleshooting

⚠ Interference with and repairs to the hob MUST NOT be carried out by unqualified persons. Do not try to repair the hob as this may result in injury and damage to the hob. Please arrange for repair by a suitably competent person.

Note: The induction hob is able to self-diagnose a number of problems and can show this information to the user via the hob control display. Error codes may be displayed if your hob has developed a fault.

If your appliance reports an error or is not working, you may be able to correct the fault by consulting the following.

Error code E2 is displayed

The electronic unit is too hot. Please check the installation of the cooker, making sure that there is sufficient ventilation. In extreme cases, if a cooking utensil has been allowed to boil dry this error code may also be displayed. If in doubt please contact your installer or a qualified repair engineer.

No display operation

Over voltage or loss of supply voltage to the cooker. If in doubt please contact your installer or a qualified repair engineer.

Error code U400 is displayed

The cooker has been incorrectly connected. The control will switch off after approximately 1 second and the error code will be permanently displayed.

Consult your installer or a qualified repair engineer.

Error code Er followed by a number is displayed

The appliance has developed an internal technical fault that cannot be rectified by the user.

Consult your installer or a qualified repair engineer.

The fuse blows or the RCD trips regularly

Please contact your installer or a qualified repair engineer.

The cooker will not switch on

Has the wiring system in the house blown a fuse or tripped an RCD?

Has the cooker been correctly connected to the mains supply?

The induction hob is noisy

When using the induction hob there may be some 'noise' emitted from the pan. This is normal and may be most noticeable when cooking on high power settings or if 5 pans are used simultaneously. The type of pan may also contribute to induction 'noise'.

The cooling fan

The induction hob incorporates a cooling fan. This cooling fan is active when either the grill or the oven(s) are on. Under certain conditions, the cooling fan may remain active when the grill or oven(s) are switched off. This is normal and the fan will switch off automatically.

The fascia gets hot when I use the oven

If the fascia becomes excessively hot when the cooker is in use then the cooling fan may have failed. Should this occur please contact your installer, a qualified repair engineer or Customer Service to arrange for its repair.

A crack has appeared in the hob surface

Disconnect the cooker immediately from the power supply and arrange for its repair. Do not use the cooker until after the repair.

My hob is scratched

Always use the cleaning methods recommended in this guide, and make sure that the pan bottoms are smooth and clean.

Marks from mineral deposits from water or food can be removed with a cleaning cream. However, tiny scratches are not removable but will become less visible in time as a result of cleaning.

The oven fan is noisy

The note of the oven fan may change as the oven heats up – this is perfectly normal.

The knobs get hot when I use the oven or grill. Can I avoid this?

Yes, this is caused by heat rising from the oven or the grill, and heating them up. Do not leave the oven door open. Make sure that the grill pan is pushed right back to the 'back stop' when grilling.

ALWAYS grill with the grill compartment door open.

DO NOT leave the oven door open.

If there is an installation problem and I don't get my original installer to come back to fix it, who pays?

You do. Service organisations will charge for their call-outs if they are correcting work carried out by your original installer. Therefore, it's in your own interest to keep track of this installer so that you can contact them as required.

Food is cooking too slowly, too quickly, or burning

Cooking times may differ from your previous oven. Check that you are using the recommended temperatures and shelf positions – see the oven cooking guide. Then adjust the settings according to your own individual tastes.

The oven is not cooking evenly

Do not use a baking tray with dimensions larger than those specified in the section on 'General Oven Tips'.

If you are cooking a large item, be prepared to turn it round during cooking.

If two shelves are used, check that space has been left for the heat to circulate. When a baking tray is put into the oven, make sure that it is placed centrally on the shelf.

Check that the door seal is not damaged and that the door catch is adjusted so that the door is held firmly against the seal.

A dish of water when placed on the shelf should be the same depth all over. (For example, if it is deeper at the back, then the back of the cooker should be raised up or the front lowered.) If the cooker is not level, arrange for your supplier to level it for you.

Power failure

In the event of a failure in the electrical supply, remember to reset the clock so that the timed oven continues to operate.

The timed oven is not coming on when turned on manually

Is the power on? Is the clock illuminated? If not, there may be something wrong with the power supply. Is the cooker supply on at the isolator switch?

Has the time of day been set?

The timed oven is not coming on when automatic cooking

Has the oven knob been left in the OFF position by mistake?

Oven temperature getting hotter as the cooker gets older

If turning the temperature down using the oven control knob has not worked, or has only worked for a short time, then you may need a new thermostat. This should be fitted by a service person.

Multifunction oven light is not working

The bulb has probably blown. You can buy a replacement bulb (which is not covered under the guarantee) from most electrical stores. Ask for a 40W – 230V halogen lamp (G9) (**Fig. 7.1**).

Before removing the existing bulb, turn off the power supply and make sure that the oven is cool. Open the oven door and remove the oven shelves.

Locate the bulb cover and unscrew it by turning it counter-clockwise – it may be very stiff (**Fig. 7.2**).

Pull the existing bulb to remove it. When handling the replacement bulb, avoid touching the glass with your fingers, as oils from your hands can cause premature failure. Push, click in the replacement bulb.

Replace the bulb cover by turning it a quarter turn, clockwise. Turn on the circuit breaker and check that the bulb now lights.

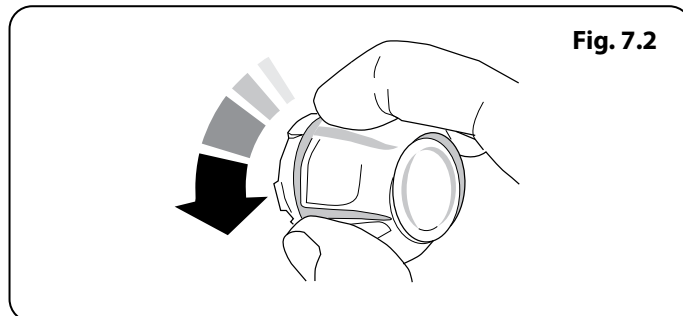
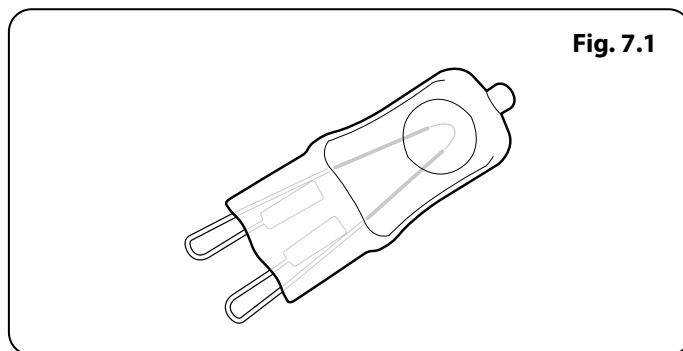
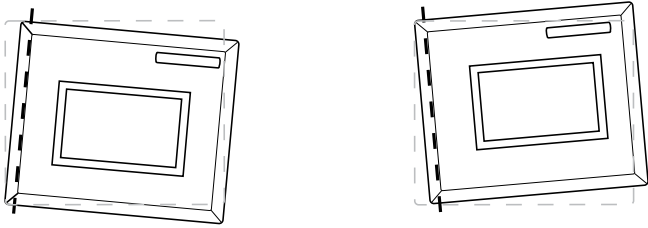
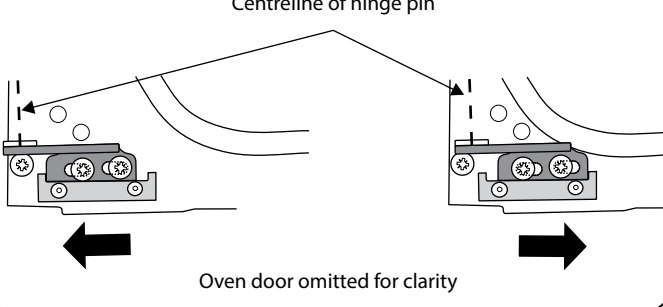

Fig. 7.3



Effect of hinge adjustment - exaggerated for clarity

Fig. 7.4



Oven door omitted for clarity

Fig. 7.5

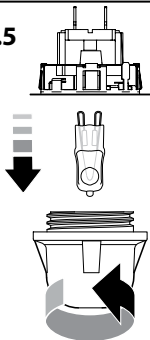
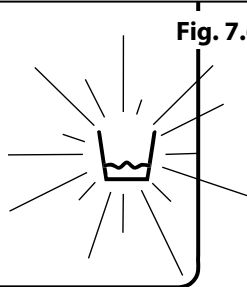

Fig. 7.6



The left-hand oven door is misaligned

The bottom hinge of the left-hand oven door can be adjusted to alter its angle (**Fig. 7.3**).

Loosen the bottom hinge fixing screws and use the notch and a flat bladed screwdriver to move the position of the hinge to set the hinge position (**Fig. 7.4**).

Retighten the hinge screws.

Steam cavity light is not working

The bulb has probably burnt out. You can buy a replacement bulb (which is not covered under the warranty) from a good electrical shop. Ask for a **25W - 230V** halogen lamp (G9) (**Fig. 7.1**).

WARNING: Before removing the existing bulb, turn off the power supply and make sure that the oven and bulb have cooled. Open the oven door and remove the oven shelves.

Remove the bulb cover by turning it, counter-clockwise. It may be very stiff (**Fig. 7.5**).

Pull the existing bulb to remove it. When handling the replacement bulb, avoid touching the glass with your fingers, as oils from your hands can cause premature failure. Push, click in the replacement bulb.

Replace the bulb cover by turning it clockwise. Turn on the circuit breaker and check that the bulb now lights.

Moisture visible on the steam cavity door

This is normal. Wipe away excess moisture once cooking is complete.

The Steam oven beeps and makes a noise but there is the flashing of the start/pause button and another flashing symbol (Fig. 7.6).

Problem: Low water level in the water tank or water tank is not in place. The steam cavity will not operate.

To fix this, place the water tank in the correct position ensuring that the water tank is fully engaged and an audible click is heard.

INSTALLATION

Check the appliance is electrically safe and gas sound when you have finished.

8. Installation

Dear Installer

Before you start your installation, please complete the details below, so that, if your customer has a problem relating to your installation, they will be able to contact you easily.

| |
|-------------------------------------|
| Installer's Name |
| |
| Installer's Company |
| |
| Installer's Telephone Number |
| |
| Appliance Serial Number |
| |

Safety Requirements and Regulations

- ⚠** This cooker must be installed in accordance with the relevant instructions in this booklet, with the relevant national and local regulations, and with the local electricity supply companies' requirements.
- ⚠** The appliance must be installed in accordance with the regulations in force and only in a well ventilated space.
- ⚠** Read the instructions before installing or using this appliance.

Provision of Ventilation

This appliance is not connected to a combustion products evacuation device. Particular attention shall be given to the relevant requirements regarding ventilation.

All rooms require a window that can be opened, or equivalent, while some rooms require a permanent vent in addition to the window.

Location of Cooker

The cooker may be installed in a kitchen/kitchen diner but **NOT** in a room containing a bath or shower.

You will need the following equipment to complete the cooker installation satisfactorily:

Multimeter (for electrical checks).

You will also need the following tools:

1. Steel tape measure
2. Cross-head screwdriver
3. Flat-bladed screwdriver
4. Spirit level
5. Pencil
6. Adjustable spanner
7. 3 mm and 4 mm Allen keys
8. 13 mm spanner or socket wrench

Checking the parts:

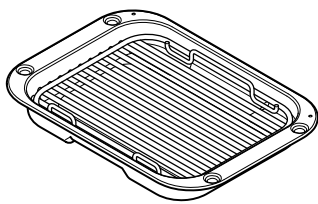
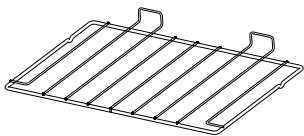
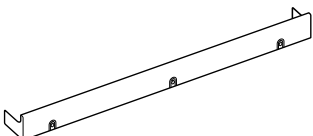
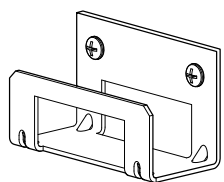
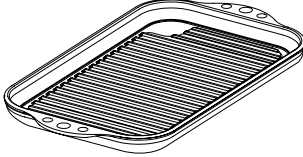
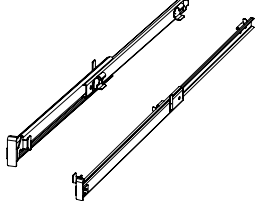
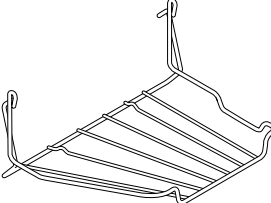
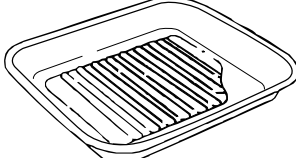
| | |
|--|---|
| Grill pan & trivet | Flat shelves |
|  |  |
| Plinth | Stability location bracket |
|  |  |
| Induction griddle | 2 x set of Telescopic runners |
|  |  |
| Handyrack (optional) | Roasting tin (Optional) |
|  |  |

INSTALLATION

Check the appliance is electrically safe and gas sound when you have finished.

Positioning the Cooker

Fig. 8.1 and **Fig. 8.2** shows the minimum recommended distance from the cooker to nearby surfaces.

The cooker should not be placed on a base.

Fig. 8.1 and **Fig. 8.2** Cookers installed into recess: The cooker must have side clearance **ABOVE** hob level of 75mm up to a height of 410mm. This can be reduced to 25mm if the surface of the side wall is non-combustible.

A minimum space of 650 mm is required between the top of the hob and a horizontal combustible surface.

*Any cookerhood should be installed in accordance with the hood manufacturer's instructions.

**Any splashback must be fitted in accordance with the manufacturers instructions. Allowance should be made for the additional height of the flue trim, which is fitted to the cooker hob.

Surfaces of furniture and walls at the sides and rear of the appliance should be heat, splash and steam resistant. Certain types of vinyl or laminate kitchen furniture are particularly prone to heat damage and discolouration. We cannot accept responsibility for damage caused by normal use of the cooker to any material that de-laminates or discolours at temperatures less than 65°C above room temperature.

DO NOT box the cooker in – it must be possible to move the cooker in and out for cleaning and servicing.

To allow the oven doors to open, a clearance of 130 mm is required if the cooker is near a corner of the kitchen (**Fig. 8.3**). The actual opening of the doors is slightly less, but this allows for some protection of your hand as you open the door.

Moving the Cooker

We recommend that two people manoeuvre the cooker. Make sure that the floor covering is firmly fixed, or removed, to prevent it being disturbed when moving the cooker around.

To help you, there are two levelling rollers at the back, and two screw-down levelling feet at the front.

Remove the polystyrene base pack. From the front, tilt the cooker backwards and remove the front half of the polystyrene base (**Fig. 8.4**).

Repeat from the back and remove the rear half of the polystyrene base.

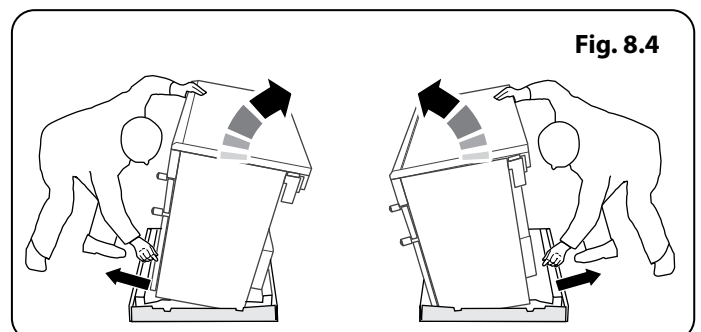
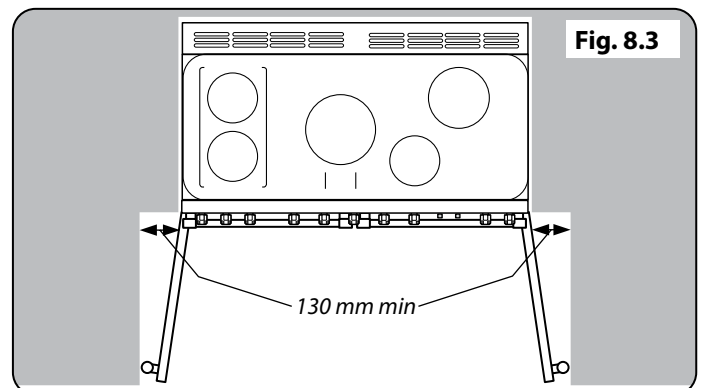
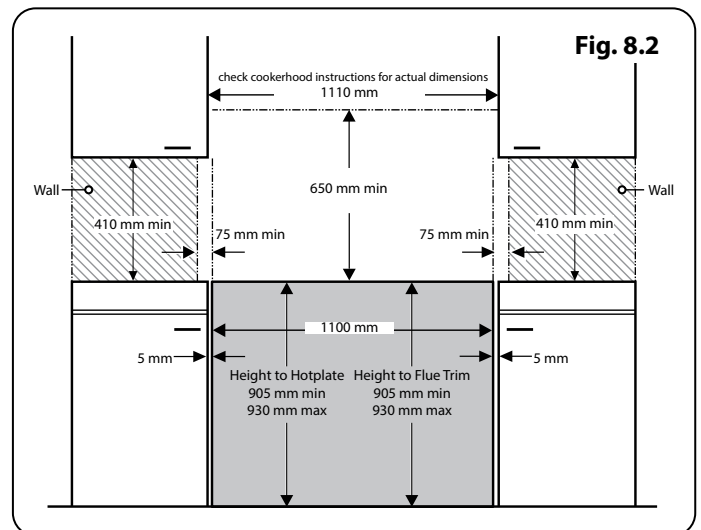
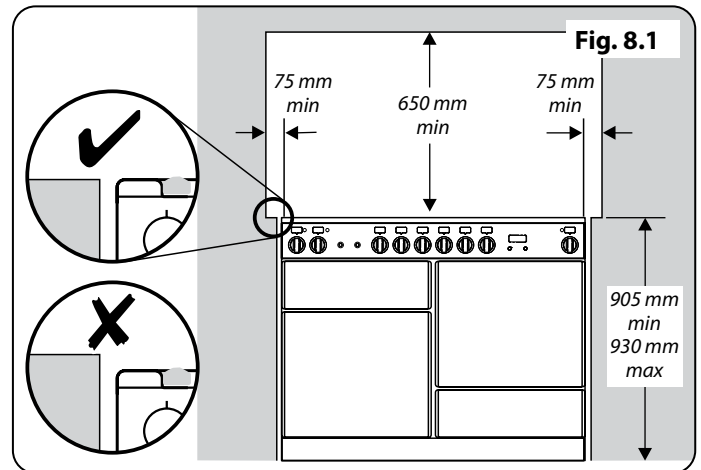

INSTALLATION

Check the appliance is electrically safe and gas sound when you have finished.

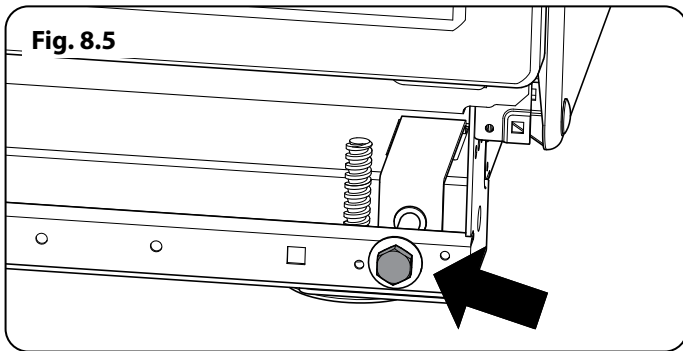

Lowering the Two Rear Rollers

To adjust the height of the rear of the cooker, first fit a 13 mm spanner or socket wrench onto the hexagonal adjusting nut (**Fig. 8.5**). Rotate the nut – clockwise to raise – counter-clockwise to lower.

Make 10 complete (360°) turns clockwise.

Make sure you lower BOTH REAR ROLLERS.

Completing the Move

Unfold the rear edge of the cardboard base tray. Open the oven doors so that you can get a good grip on the bottom of the fascia panel as you move the oven (**Fig. 8.6**).

Carefully push the cooker backwards off the base tray. Remove the base tray.

Position the cooker close to its final position, leaving just enough space to get behind it **Fig. 8.7**).

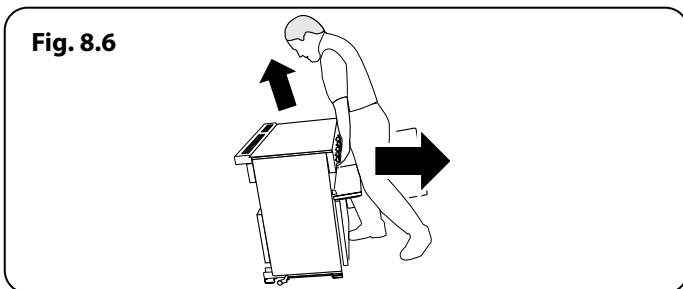

Fitting the Stability Bracket

We recommend using a stability bracket; first attach the bracket location device to the rear of the cooker (**Fig. 8.8**). Then adjust the bracket to engage through the slot of the device (**Fig. 8.9** and **Fig. 8.10**).

Repositioning the Cooker Following Connection

If you need to move the cooker once it has been connected then you need to unplug it and, having gripped under the fascia panel and lifted the front of the cooker slightly (**Fig. 8.6**); you need to check behind the cooker to make sure that the gas hose is not caught.

As you progress, make sure that both the electricity cable and gas hose always have sufficient slack to allow the cooker to move.

With a stability chain fitted, release it as you ease the cooker out. Do not forget to refit it when you replace the cooker.

When you replace the cooker, again check behind to make sure that the electricity cable and gas hose are not caught or trapped.

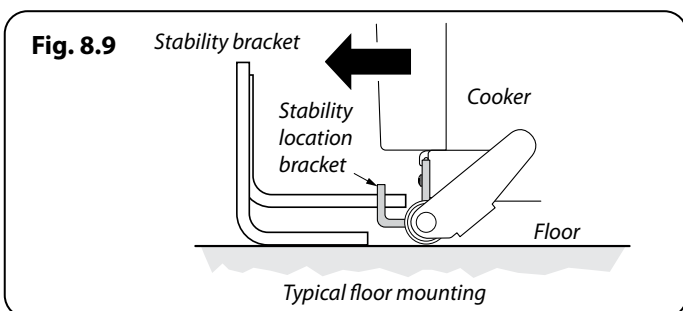
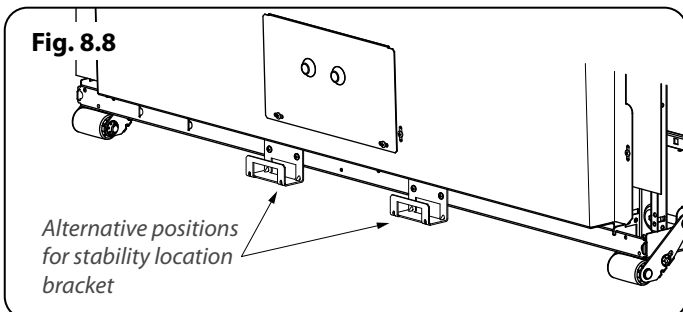
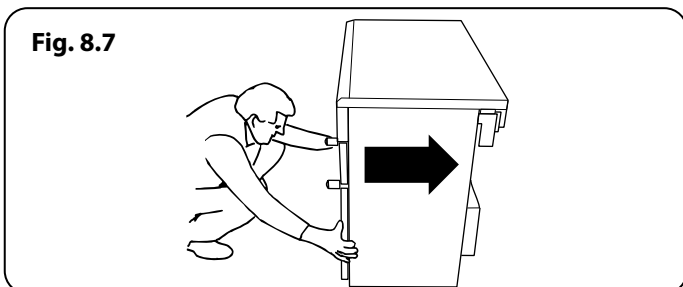

Levelling

You are recommended to use a spirit level on a shelf in one of the ovens to check for level.

Place the cooker in its intended position taking care not to twist it within the gap between the kitchen units as damage may occur to the cooker or the units.

The front feet and rear rollers can be adjusted to level the cooker.

To adjust the height of the rear of the cooker use a 13 mm spanner or socket wrench to turn the adjusting nuts at the front bottom corners of the cooker.

To set the front, turn the feet bases to raise or lower.

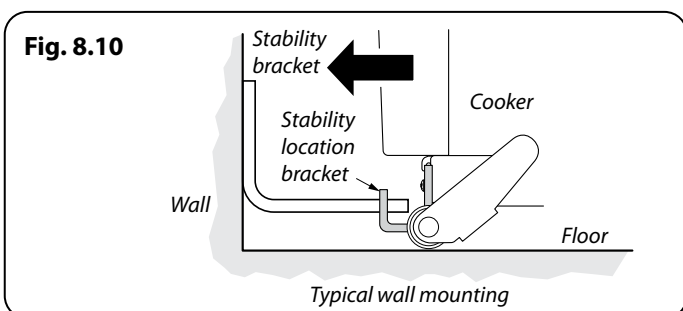

INSTALLATION

Check the appliance is electrically safe and gas sound when you have finished.

Electrical Connection

This appliance must be installed by a qualified electrician to comply with with current AS/NZS 3000 Wiring Rules and regulations in force.

Make sure that the mains characteristics (voltage, nominal, power, etc.) match the ratings indicated on the data plate affixed to the cooker.

The cooker is preset for a single-phase earthed electrical connection. It is essential to install a multi-pole circuit breaker that completely disconnects the appliance from the mains, with a minimum contact break distance of 3 mm.

⚠ WARNING: THE APPLIANCE MUST BE EARTHED.

The appliance must be connected to an efficient earthing circuit. If the electricity network is not equipped with an earth connection, then it must be installed separately in compliance with local regulations.

Earthing is a safety measure required by law, and must be performed with particular care by a qualified technician, who must also check that the electricity supply characteristics are correct.

The total electrical load of the appliance is approximately 15.0 kW. The cable size used should be suitable for this load and comply with all local requirements (i.e. PVC Insulated cable IEC 60227 – code 53 for ordinary cables).

Access to the mains terminal is gained by removing the electrical terminal cover box on the back panel. Connect the mains cable to the correct terminals for your electrical supply type (**Fig. 8.11** and **Fig. 8.12**). Check that the links are correctly fitted and that the terminal screws are tight. Secure the mains cable using the cable clamp.

An isolation switch shall be provided and mounted near the cooker, in a readily accessible position, in compliance with AS/NZS 3000 and/or AS/NZS 5601 as applicable for the appliance configuration.

- Type of cord in accordance with IEC 60227 with a minimum rating of 90°C
- Cord Size - (Power cables may be sized to take into account the coincidence factor (AS/NZS 60335.2.6:2014) – Recommended for this application is 3 x 10 mm² three-core cable.
- Rating of the plug – 32 Amp (In accordance with AS/NZS 3112.) (Based on the Arithmetic mean value when measured under full load stabilized conditions, Clause 10 IEC 60335-1)

Current Operated Earth Leakage Breakers

The combined use of your induction cooker and other domestic appliances may cause nuisance tripping, so we recommend that the cooker is protected on an individual RCD (Residual Current Device) or RCBO (Residual Current Breaker with Overload).

IF IN DOUBT, PLEASE CONSULT A SUITABLY QUALIFIED ELECTRICIAN.

Fig. 8.11

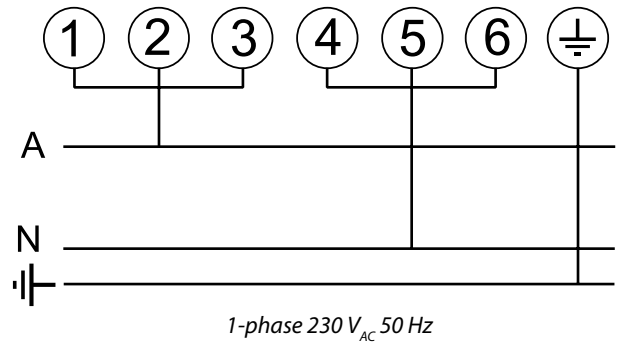
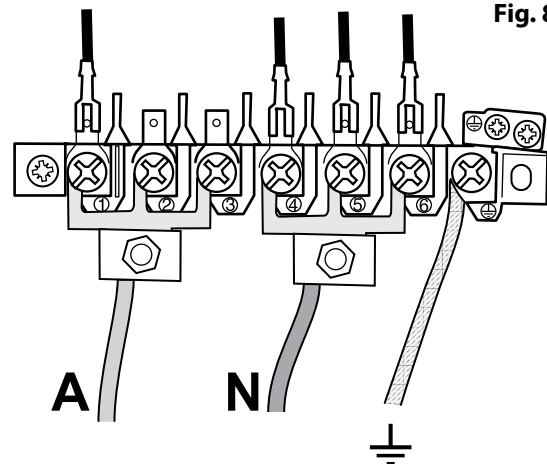

Fig. 8.12



INSTALLATION

Check the appliance is electrically safe and gas sound when you have finished.

Fig. 8.13

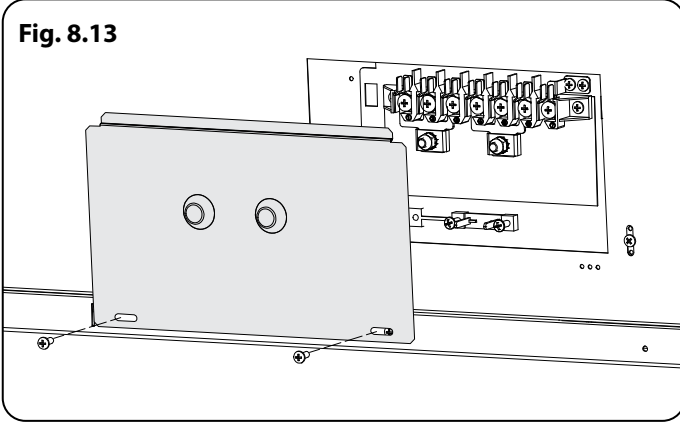

Fig. 8.14

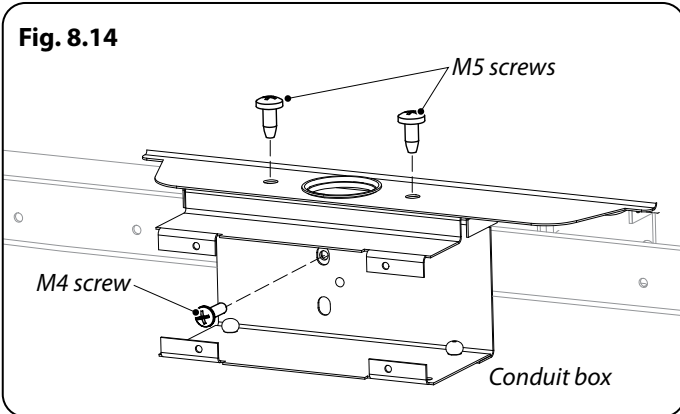

Fig. 8.15

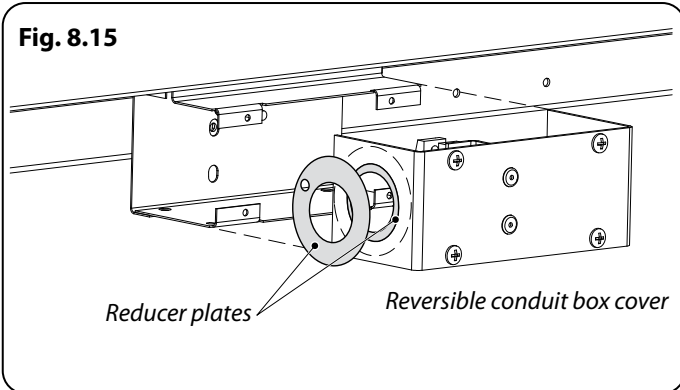
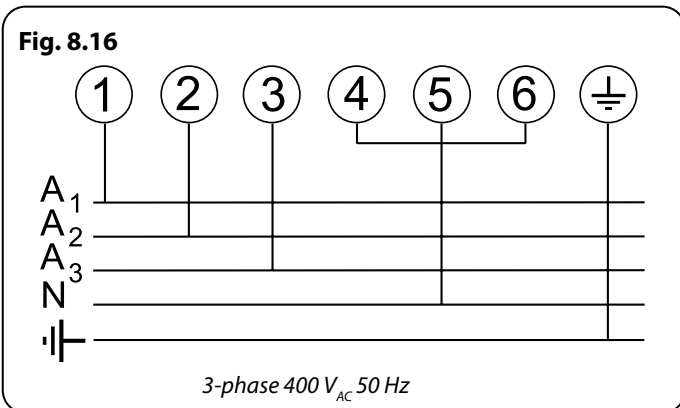

Fig. 8.16



Connection in New Zealand

Type of cord in accordance with **IEC 60227** with a minimum rating of 90°C.

Cord size recommended for this application is 3 x 10 mm², three-core cable (Power cables may be sized to take into account the coincidence factor **AS/NZS 60335.2.6:2014**).

Rating of the plug is 32 Amp, in accordance with **AS/NZS 3112**. Based on the arithmetic mean value when measured under full load stabilized conditions, **Clause 10 IEC 60335-1**.

If this cooking range is to be connected to a new or upgrade electrical installation, then it must be connected to the supply by a supply cord fitted with:

- An appropriately rated plug that is compatible with the socket – outlet fitted to the final sub –circuit in the fixed wiring that supplies this cooking range

OR

- An appropriately rated installation male connector that is compatible with the installation female connector fitted to the final sub circuit in the fixed wiring that supplies this cooking range.

Note: The marking for the rated current of the fuse protecting a socket should be placed on or near the socket outlet.

Fixed Wiring

⚠ DISCONNECT FROM THE MAINS SUPPLY.

For connection to fixed wiring, i.e. flexible conduit, remove the electrical terminal cover on the back panel (**Fig. 8.13**).

Fit the conduit box to the cooker using the two M5 screw fittings located at the top of the box. Remove the M4 screw from the base, and fix to the cooker, via the fitting through the back of the conduit box (**Fig. 8.14**).

The conduit box cover is reversible. Fit the reducer plate if required (**Fig. 8.15**). Feed the cable through the conduit box and secure in place with the cable clamp.

Connect the mains cable to the correct terminals for your electrical supply type (**Fig. 8.16**). Check that the links are correctly fitted and that the terminal screws are tight.

Fit the cover to the conduit box.

INSTALLATION

Check the appliance is electrically safe and gas sound when you have finished.

Final Checks

Hob Check

Check each cooking zone in turn. Be sure to use pans of the correct size and material.

Grill Check

Turn on the grill control and check that the grill heats up.

Oven Check

Set the clock as described earlier, and then turn on the ovens. Check the oven fans start to turn and that the ovens heat up.

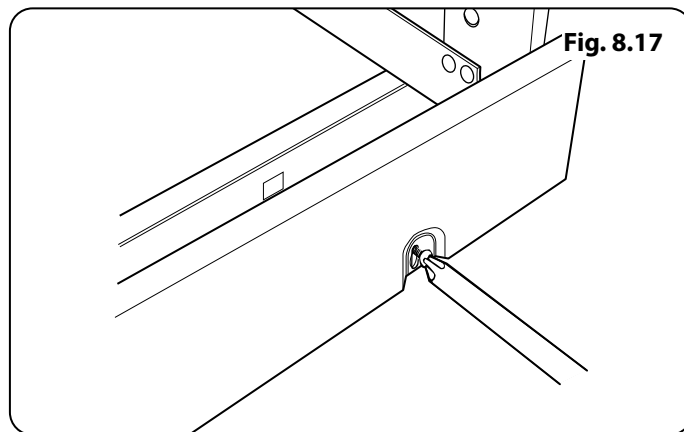

Final Fitting

Fitting the Plinth

Loosen the 3 screws along the front bottom edge of the cooker. Twist and fit each end keyhole over their respective screws. Tighten the fixing screws (**Fig. 8.17**).

Customer Care

Installer: Please complete your details in this guide, inform the user how to operate the cooker and hand over the instructions.

9. Servicing

⚠ **Disconnect from the electricity supply before servicing, particularly before removing any of the following: control panel, side panels, ceramic hob or any electrical components or covers.**

⚠ **Before electrical reconnection, check that the appliance is electrically safe.**

1 Panels

1.1 To Remove the Control Panel

⚠ **DISCONNECT FROM THE ELECTRICITY SUPPLY.**

Pull off all the control knobs and remove the fixing screws underneath the control panel.

The control panel will drop down slightly. It is held at the top by two holes in the top edge, one at each end, that locate on the tags on the inner panel. Lift the control panel clear of the tags and pull forwards, taking care not to damage or strain the wiring.

1.2 To Remove the Side Panels

⚠ **DISCONNECT FROM THE ELECTRICITY SUPPLY.**

Remove the control panel (see 1.1). Pull the cooker forward. Remove the 4 retaining screws for each panel (1 at the front base, 1 on the top and 2 at the rear).

Reassemble in the reverse order.

2 Hotplate

⚠ **DISCONNECT FROM THE ELECTRICITY SUPPLY.**

2.1 To Lift up the Induction Hob

Remove the rubber plugs and retaining screws (1 each side) at the top front of the side panels.

Lift up the induction hob at the front and prop into position with a non-metallic prop.

CAUTION: The induction hob material is much more sensitive to scratches on the underside than the top.

Take care not to touch or scratch the underside of the ceramic as this will weaken the material and cause the top to shatter.

3 Controls

3.1. To Replace the Light Switch

⚠ **DISCONNECT FROM THE ELECTRICITY SUPPLY.**

Remove the control panel (see 1.1).

Note: The old switch may be destroyed during removal. Remove the old switch from its bezel by gripping the switch body behind the control panel and twisting sharply. Remove the switch bezel by folding back the locking wings and pushing forward. To fit the new bezel to the control panel: first line up the raised key on its body with the cut-out in the control panel and push it in from the front.

Assemble the new switch to the bezel by lining up the key sections and pushing home. Fit the new button by pushing in from the front.

Replace the control panel in the reverse order and test for correct operation.

4 Grill

4.1 To Replace the Grill Controller

⚠ **DISCONNECT FROM THE ELECTRICITY SUPPLY.**

Remove the control panel and hotplate (see 1.1 & 2.1). Disconnect the wiring from controller. Remove the 2 screws holding the controller to the mounting panel.

Fit the new controller and reassemble in the reverse order. Check for correct operation.

4.2 To Replace the Grill Element

⚠ **DISCONNECT FROM THE ELECTRICITY SUPPLY.**

Remove the grill pan from the grill chamber. From inside the grill compartment, undo the 2 screws and washers and remove the enamelled front shield from the grill roof. Remove 2 screws and washers securing the grill element front support. Remove the screws from the grill elements.

Carefully lift the elements out and disconnect the leads from the element terminals, noting their position.

If it is not possible to disconnect the leads in this way, pull cooker forwards to gain access to the rear.

Remove the screws securing the electric cover to the back sheet, and then remove cover and disconnect the terminals from the rear.

Fit the new elements and reassemble in reverse order. Check the operation of the grill.

5 Ovens

5.1 To Replace the Left-hand Oven Thermostat

⚠ **DISCONNECT FROM THE ELECTRICITY SUPPLY.**

Remove the control panel and hotplate (see 1.1 & 2.1). Open the oven door and remove the oven furniture.

Pull the cooker forward to gain access to the cover box at the rear of the cooker. Remove the 4 screws securing the cover and lift clear.

Feed the thermostat capillary out of the oven. Disconnect the wiring from the thermostat. Remove 2 screws holding thermostat to mounting panel. Fit new thermostat and reassemble in the reverse order. Make sure that the phial is clipped to the oven back with the phial centrally positioned between the clips.

Check the operation of the thermostat.

WARNING – SERVICING TO BE CARRIED OUT ONLY BY AN AUTHORISED PERSON
Disconnect from electricity before servicing. Check appliance is safe when you have finished.

5.2 To Remove the Left-hand Oven Inner Back

Open the left-hand oven door. Remove the screws and washers securing the inner back to the back of the oven (**Fig. 9.1**).

Carefully lift away the inner back.

Reassemble in reverse order, making sure that you fully tighten the 4 screws and washers.

5.3 To Change the Fan in the Left-hand Oven

⚠ DISCONNECT FROM THE ELECTRICITY SUPPLY.

Pull the cooker forward to gain access to the rear. Remove the screws securing the electric cover to the back sheet and remove the cover. Disconnect the 3 terminals connected to the fan, noting their position.

Remove the oven inner back (see 5.2). Hold the fan blade and remove the centre nut (left-hand thread), 2 brass washers, fan blade and circlip. Unscrew the fan retaining nuts and washers (3 off each) and lift the fan away from the rear of the cooker.

Fit the new fan and reassemble in reverse order.

Check the operation of the oven.

5.4 To Remove an Oven Element Thermal Cut-out

⚠ DISCONNECT FROM THE ELECTRICITY SUPPLY.

Pull the cooker forwards to gain access to the cover box. Undo the cover screws and lift clear.

The cut-out is located on the earth plate beside the oven element connections. Disconnect the cut-out wiring. Undo the fixings that secure the cut-out to the earth plate and remove.

Fit the replacement control and re-assemble in reverse order.

5.5 To Remove the Left-hand Oven Element

⚠ DISCONNECT FROM THE ELECTRICITY SUPPLY.

Remove the oven inner back (**see 5.2**).

Remove the 2 screws from the top of the element and the 1 from the bottom of the element (**Fig. 9.2**). Carefully lift the element out, disconnecting the terminals connected to the element (noting their positions).

If it is not possible to disconnect the leads in this way, pull the cooker forward to gain access to the rear, remove the screws securing the electric cover to the back sheet, remove the cover and disconnect the terminals from the rear.

Fit the new element and reassemble in reverse order. Check the operation of the oven.

5.6 To Remove the Left-hand Oven Bottom and Top Elements

⚠ DISCONNECT FROM THE ELECTRICITY SUPPLY.

Bottom Element

Pull the cooker forward to access the cover boxes at the rear of the unit. Remove the fixings that secure the cover and lift it clear.

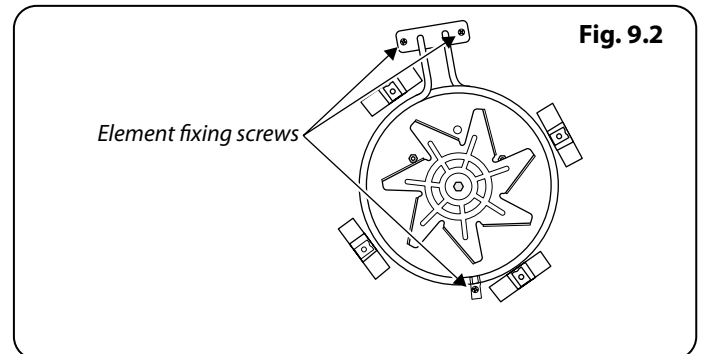
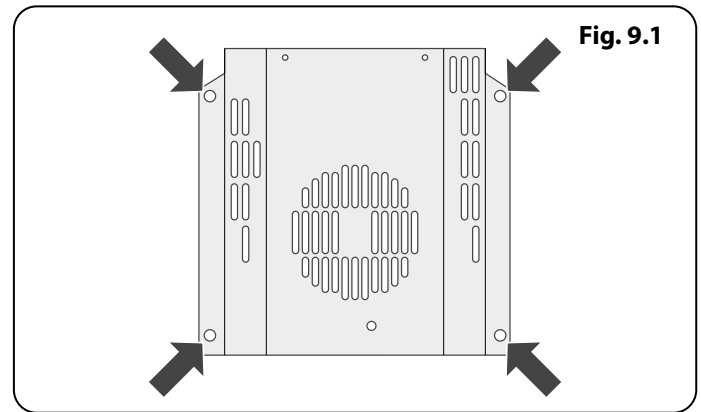

WARNING – SERVICING TO BE CARRIED OUT ONLY BY AN AUTHORISED PERSON
Disconnect from electricity before servicing. Check appliance is safe when you have finished.

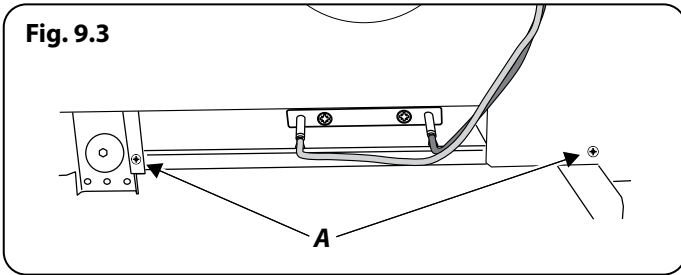

Remove the 2 screws 'A' and allow the plate to drop down (Fig. 9.3). Remove the 2 screws 'B'; lower the upper plate and remove through the slot in the cooker back (Fig. 9.4).

Undo the terminal connections, noting their positions.

Remove the element fixings and withdraw the element. Replace the element and re-assemble parts in reverse order.

Top Element

Open the left-hand oven door and undo the fixings that secure the heat shield. Remove the top element bracket fixings and withdraw element. Replace the element and re-assemble parts in reverse order.

Check the oven operation.

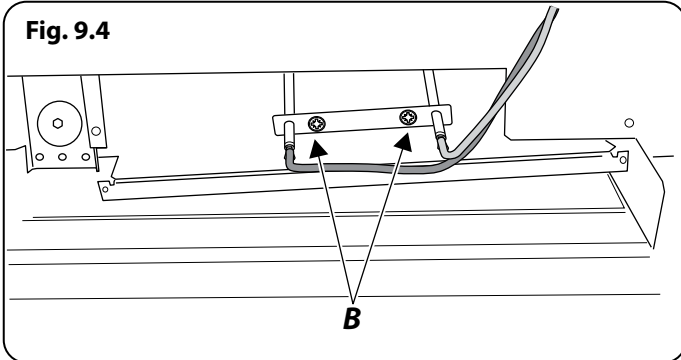

6 Doors

6.1 To Remove the Grill Door

Remove the left-hand side panel (see 1.2). Remove the plinth (4 screws) and the central vertical cover (5 screws). Remove the 2 countersunk screws (1 each side) securing the grill hinge arms to the front of the grill chamber.

Note: The arms are spring tensioned. Carefully remove the grill door. Retain the gaskets.

Reassemble in reverse order, making sure that the gasket is fitted between the hinge arm and the front of the grill chamber.

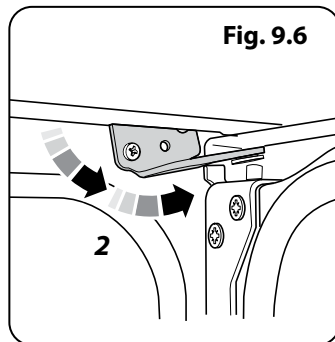
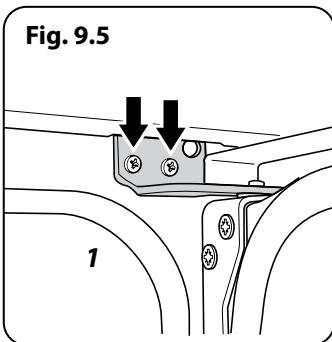

6.2 To Replace the Left-hand Oven Door

Open the oven door. Support the door and loosen the 2 screws securing the upper hinge and gasket to the cooker front (Fig. 9.5).

⚠ The door is heavy, so take care.

Support the door and remove the screw nearest the hinge pin (Fig. 9.6). Swing the hinge up and away from the door hinge pin. Lift the door away from the lower hinge and remove. Reassemble in reverse order.

6.3 To Adjust the Left-hand Oven Door Angle

The bottom hinge of the left-hand oven door can be adjusted to alter the angle of the door (Fig. 9.7). Loosen the bottom hinge fixing screws and use the notch and a flat bladed screwdriver to move the position of the hinge to set the hinge position (Fig. 9.8).

Retighten the hinge screws.

6.4 To Replace an Oven Door Outer Panel

Move the cooker forwards to gain access to the sides.

Open the oven door slightly and remove the 4 front panel fixing screws from the door sides (2 each side), (Fig. 9.9). Carefully lift off the outer door panel.

Remove the door handle from the panel by unscrewing the 2 retaining nuts. Fit the door handle to the new panel. Fit the panel to the door. Reassemble in the reverse order.

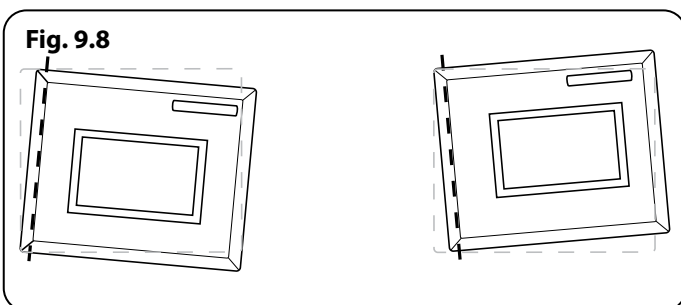
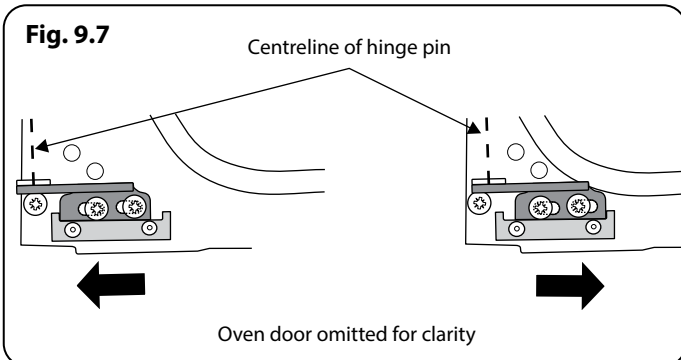

WARNING – SERVICING TO BE CARRIED OUT ONLY BY AN AUTHORISED PERSON
Disconnect from electricity before servicing. Check appliance is safe when you have finished.

6.5 To Change the Oven Door Latch

Remove the outer door panel (see 6.4). Remove screws 'B', which hold the latch assembly to the inner door panel (**Fig. 9.10**). Fit the new catch and reassemble in reverse order. Check the door operation.

6.6 To Adjust an Oven Door Catch Keep

Open the oven door, slacken off the locknut at the base of the keep, and screw in or out as required until the required fit is obtained. Retighten the locking nut (**Fig. 9.11**).

6.7 To Change an Oven Door Seal

Open the oven door. The seal is held in place by small hooks on the rear face. At the corner, pull the seal diagonally away from the door centre until that hook is released (**Fig. 9.12**). Proceed to the next hook and release it in a similar way, and so on. Use force if the hooks are stiff, as the old seal will be discarded.

When fitting the new seal, position the seal join at the bottom. Hook the new seal in one of the corner holes of the door, and proceed round the door, snapping in each hook in turn.

6.8 Oven Door Glass

The glass on the oven doors is not replaceable.

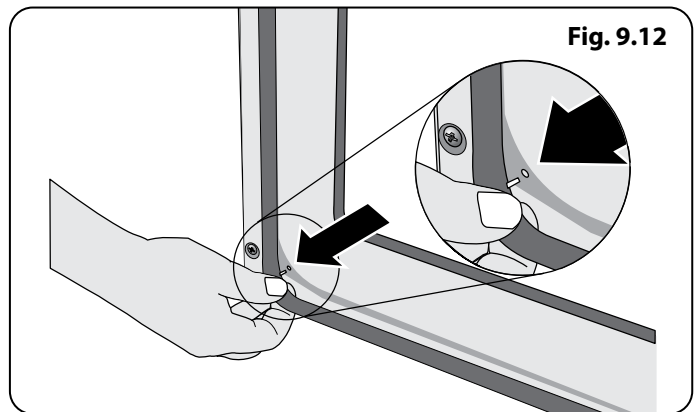
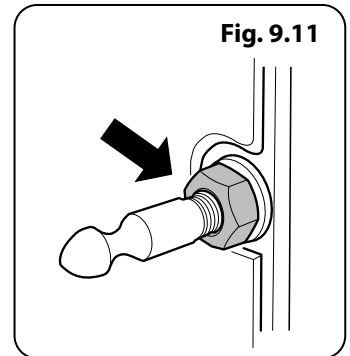
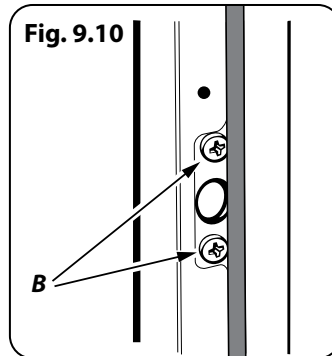
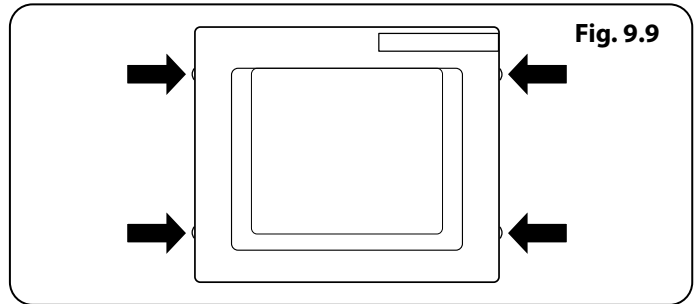

10. Circuit Diagram

Hob

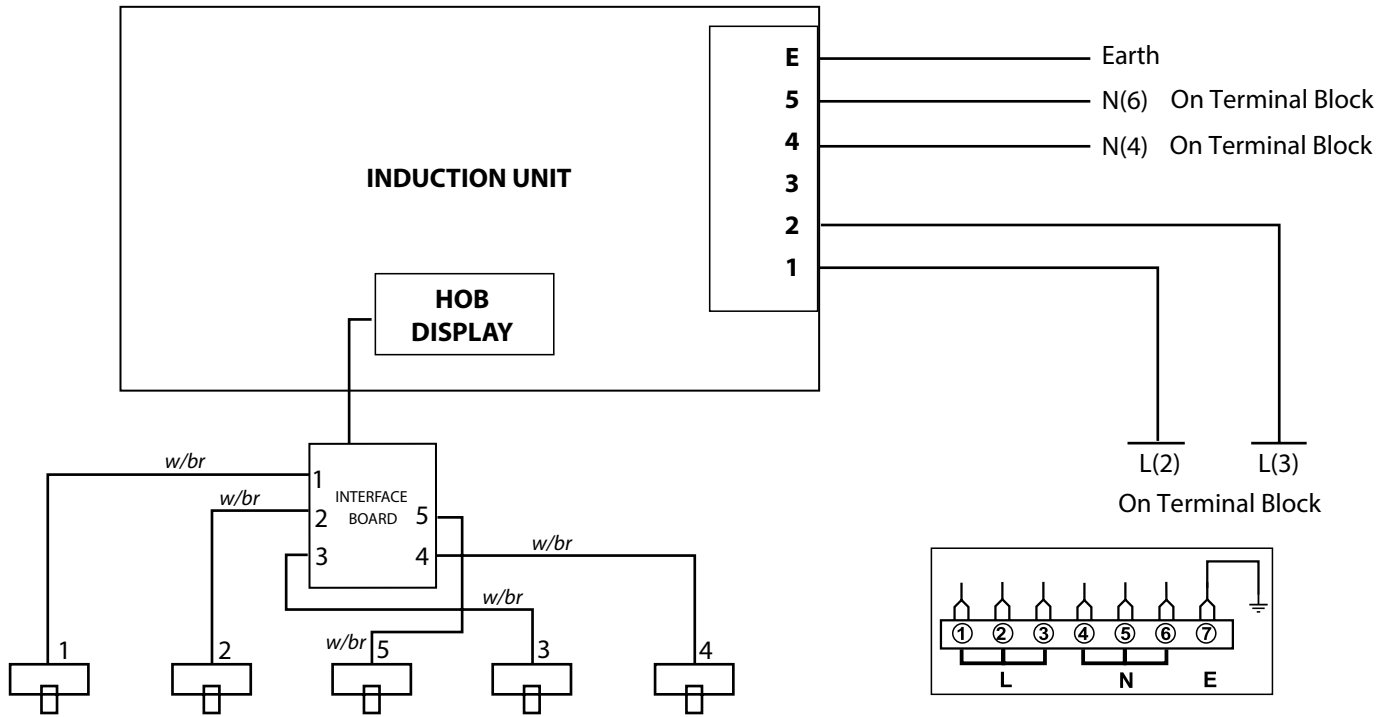

Key

The connections shown in the circuit diagram are for single-phase. The ratings are for 230V 50Hz.

| Code | Description |
|------|--------------------------|
| 1 | Left-hand front element |
| 2 | Left-hand rear element |
| 3 | Right-hand rear element |
| 4 | Right-hand front element |
| 5 | Centre element |

| Code | Colour |
|-------------|--------------|
| b | Blue |
| br | Brown |
| g/y | Green/yellow |
| w/br | White/brown |

Oven

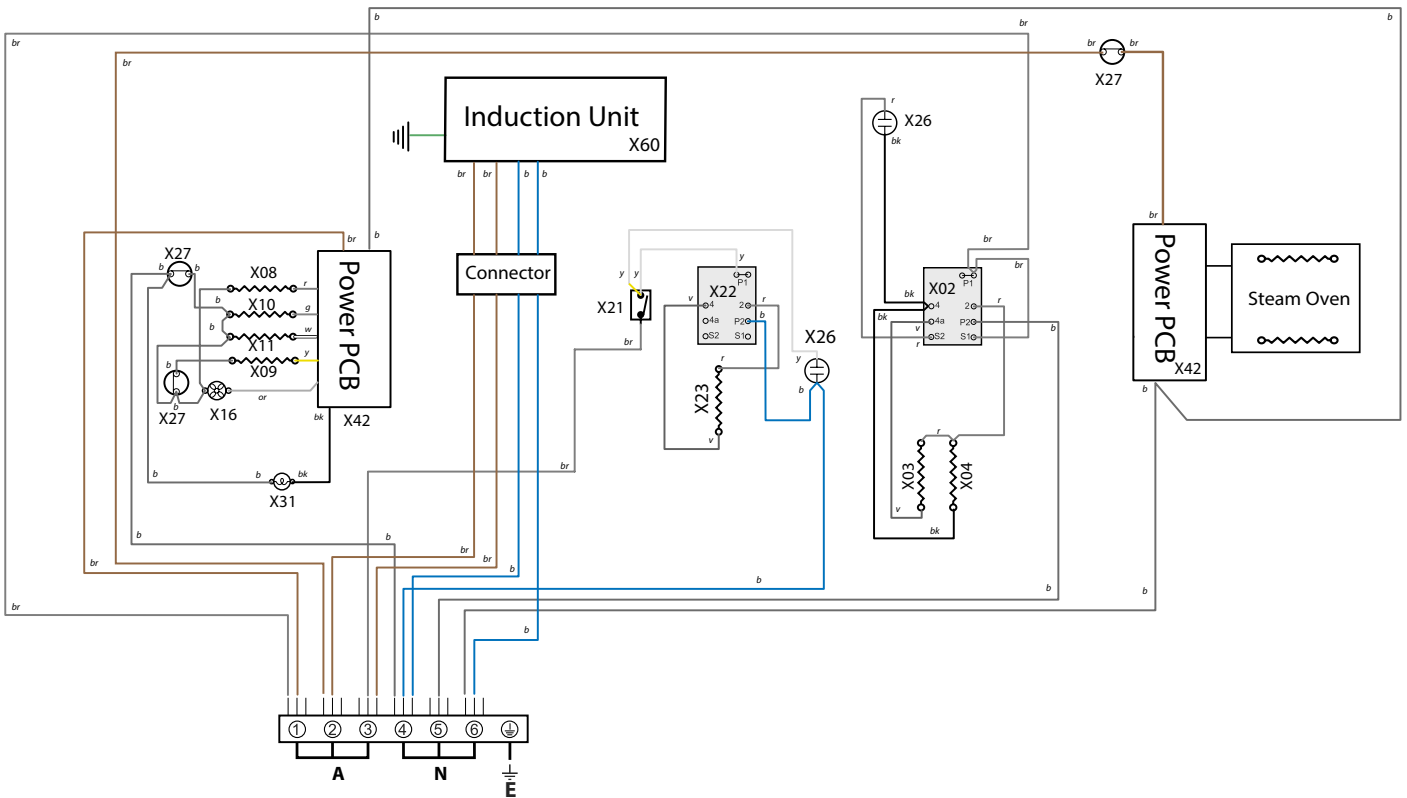

Key

The connections shown in the circuit diagram are for single-phase. The ratings are for 230V 50Hz.

| Code | Description |
|------------|----------------------------------|
| X02 | Grill Energy Regulator |
| X03 | Left Hand Grill Element |
| X04 | Right Hand Grill Element |
| X08 | Left Hand Oven Base Element |
| X09 | Left Hand Oven Fan Element |
| X10 | Left Hand Oven Top Outer Element |
| X11 | Left Hand Oven Top Inner Element |
| X16 | Oven Fan |
| X21 | Proving Drawer Switch |
| X22 | Proving Drawer Energy Regulator |

| Code | Description |
|------------|-------------------------------|
| X23 | Proving Drawer Element |
| X26 | Neon |
| X27 | Thermal Cut-Out |
| X31 | Oven Light |
| X42 | Power PCB (Steam and MF Oven) |
| X60 | Induction Unit |

| Code | Colour |
|------------|--------------|
| b | Blue |
| br | Brown |
| bk | Black |
| or | Orange |
| r | Red |
| v | Violet |
| w | White |
| y | Yellow |
| g/y | Green/Yellow |
| gr | Grey |

Power PCB

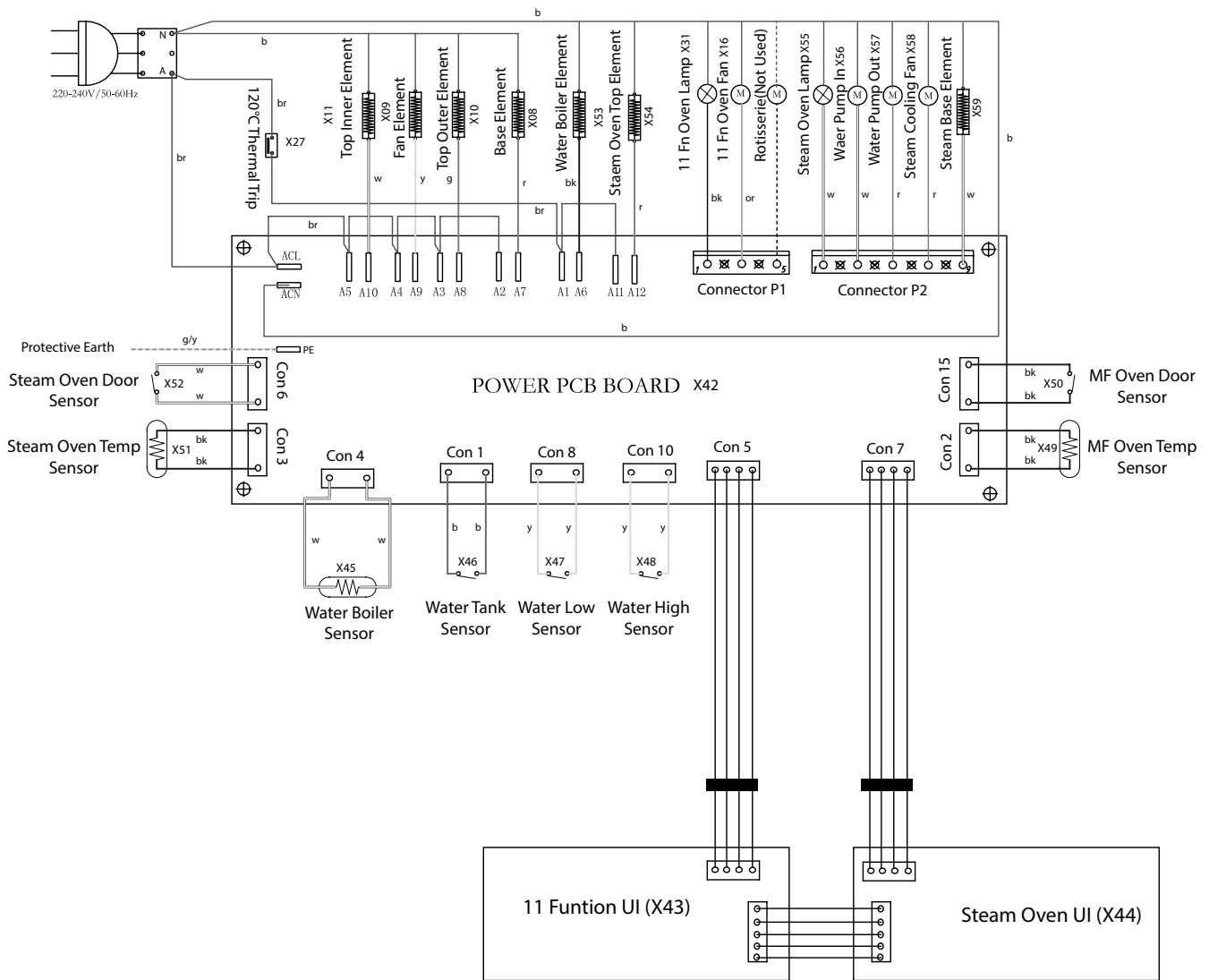

Key

The connections shown in the circuit diagram are for single-phase. The ratings are for 230V 50Hz.

| Code | Description |
|------------|----------------------------------|
| X43 | User Interface (UI) MF Oven |
| X44 | User Interface (UI) Steam Cavity |
| X45 | Water Boiler Sensor |
| X46 | Water Tank Switch |
| X47 | Water Sense (Low) |
| X48 | Water Sense (High) |
| X49 | MF Oven Temperature Sensor |
| X50 | MF Oven Door Sensor |
| X51 | Steam Cavity Temperature Sensor |
| X52 | Steam Cavity Door Sensor |

| Code | Description |
|------------|---------------------------|
| X53 | Water Boiler Element |
| X54 | Steam Cavity Top Element |
| X55 | Steam Cavity Light |
| X56 | Water Pump In |
| X57 | Water Pump Out |
| X58 | Steam Cavity Cooling Fan |
| X59 | Steam Cavity Base Element |

| Code | Colour |
|------------|--------------|
| b | Blue |
| br | Brown |
| bk | Black |
| or | Orange |
| r | Red |
| v | Violet |
| w | White |
| y | Yellow |
| g/y | Green/Yellow |
| gr | Grey |

11. Technical Data

INSTALLER: Please leave these instructions with the user.

DATA BADGE LOCATION: Cooker back, serial number repeater badge below the oven door opening.

COUNTRY OF DESTINATION: AUSTRALIA.

Connections

| | |
|----------|-----------------------|
| Electric | 230 / 400V ~ 50 Hz 3N |
|----------|-----------------------|

Dimensions

| | | |
|-----------------------------------|--|----------------|
| Model | NEXUS 110 Induction / Steam | |
| Overall height | minimum 905 mm | maximum 930 mm |
| Overall width | 1100 mm | |
| Overall depth | 608 mm excluding handles, 653 mm including handles | |
| Minimum height above the hotplate | 650 mm | |

Hotplate Ratings

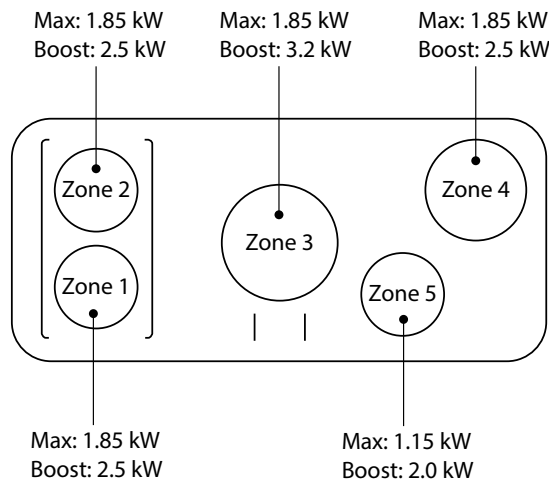

Oven Efficiency

| Ovens | Left-hand Oven Multi-function | Right-hand Oven Steam Cavity |
|--|----------------------------------|---------------------------------|
| Maximum power output @ 230V 50Hz | 3.7 kW | 1.55 kW |
| Energy efficiency class on a scale of A (more efficient) to G (less efficient) | A | - |
| Energy consumption based on standard load | 0.95 kWh | - |
| Usable volume (litres) | 79 | 35 |
| Size | Large | - |
| Time to cook standard load | 41 minutes | - |
| Surface area of the grid | 1400 cm ² | - |

| | |
|-------|--------|
| Grill | 2.3 kW |
|-------|--------|

Maximum total electrical load at 230 V (approximate total including oven lights, oven fan, etc.): 13.55 kW.

Hotplate energy saving tips

- Use cookware with a flat base.
- Use the correct size cookware.
- Use cookware with a lid.
- Minimise the amount of liquid or fat.
- When liquid starts boiling, reduce the setting.
- Once the desired griddle temperature has been reached, reduce the setting.

Oven energy saving tips

- Cook meals together, if possible.
- Keep the pre-heating time short.
- Do not lengthen cooking time.
- Do not open the oven door during the cooking period.
- Do not forget to turn the appliance off at the end of cooking.

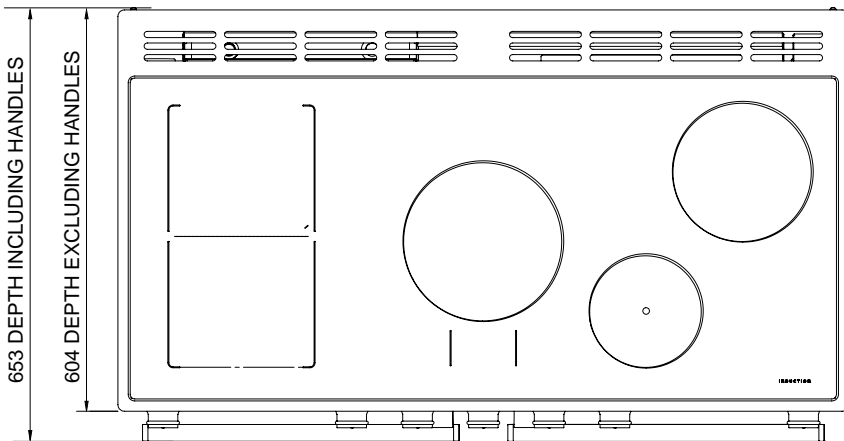
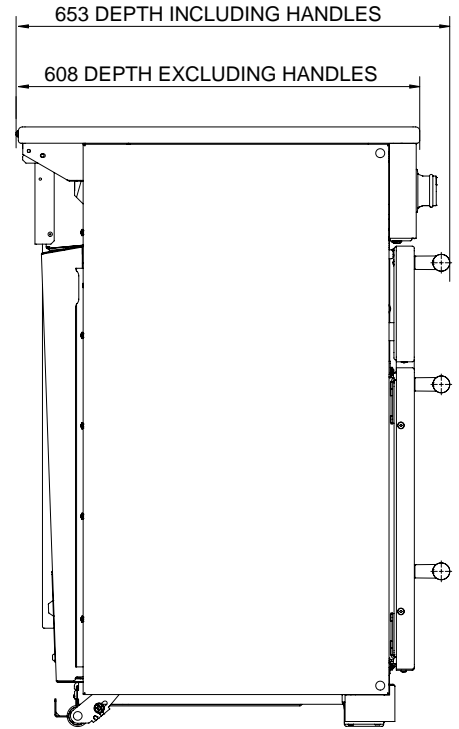
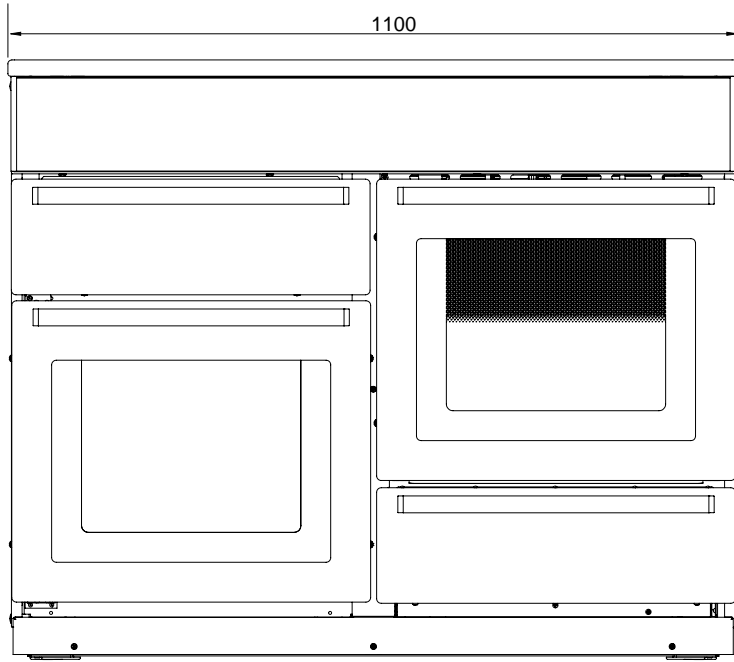

Clarence Street, Royal Leamington Spa,
Warwickshire, CV31 2AD, England.
www.falconworld.com