

EGN 9271 & EKB 9671

Quality, Design and Innovation



MONOLITH

LIEBHERR

With its impressive size, clean lines, and innovative interior features, the Monolith was designed to inspire awe and integrate seamlessly into your kitchen – today, tomorrow, and for years to come. Of the entire Monolith series, the EGN 9171 Freezer and EKB 9471 Refrigerator have been awarded the iF Design Award 2019. Indeed, Monolith takes advanced food preservation to a whole new level.

Monolith BioFresh-Plus drawer adds another dimension of climate control to the BioFresh system by allowing you to set temperatures inside the third drawer to as low as -2°C. That's the perfect temperature for preserving the freshness and flavours of seafood. The adjustable InfinityLight LED system casts beautiful and even side lighting, giving a soft, brightening effect upon opening the doors. Our intuitive electronic touch-control panel, InfinitySwipe, features a full-colour 3.5-inch touch & swipe screen that's bright, clean and wonderfully user-friendly. Stainless steel handles and fronts are available as optional accessories.

Possible Side-by-Side combinations

- EGN 9271 & EKB 9671
- EGN 9271 & EKB 9471
- EGN 9171 & EKB 9671



Monolith 152.4 cm	
Energy consumption (kWh/y) Star rating	
Sound rating dB(A) *	
Usable refrigerator capacity litre	
Usable BioFresh & BioFresh-Plus comp. litre	
Usable freezer capacity litre	
Number of shelves	
Number of door racks	
Number of FrostSafe drawers	
Number of BioFresh / BioFresh-Plus drawers	
Electronic control	
Door / side walls	
Refrigerator temperature range °C **	
Freezer temperature range °C	
Temperature alarm	
Defrost type	
Interior light	
Door alarm	
Internal water dispenser	
Water filter	
IceMaker	
Ice cube output kg/24h	
SoftSystem	
Door hinges	
Product dimensions (H/W/D) cm	
Cut out dimensions (H/W/D) cm	
Gross / Net weight kg	
Voltage (V) / Rated current (A)	
Warranty	

EGN 9271						EKB 9671					
No Frost	Infinity Swipe	Infinity Light	Ice Maker	Soft System	Soft Telescopic	Bio Fresh-Plus	Infinity Swipe	Infinity Light	Infinity Spring	Soft System	Soft Telescopic
399 3.0						263 3.5					
39						39					
-						534					
-						235					
322						-					
4						4					
3						3					
3						-					
-						2 / 1					
InfinitySwipe						InfinitySwipe					
Steel						Steel					
-						+2°C to +7°C					
-14°C to -27°C						-					
Visual and audible						Visual and audible					
Automatic						Automatic					
InfinityLight						InfinityLight					
Audible						Audible					
-						InfinitySpring					
Yes						Yes					
Fixed water connection 20 mm (3/4")						-					
1.6						-					
Yes						Yes					
Left, reversible ***						Right, reversible ***					
212.6 / 60.2 / 61						212.6 / 90.9 / 61					
213.4 / 61 / min. 63.5						213.4 / 91.4 / min. 63.5					
170 / 157						214 / 199					
220-240 / 2.0						220-240 / 1.5					
5 Years						5 Years					

* Noise output - according to EN 60704-3.
 ** BioFresh bins, 0°C. BioFresh-Plus bins, -2°C or 0°C.
 *** Please contact your Liebherr Authorised Dealer for door reversal.



Soft System

SoftSystem: Monolith's doors close automatically and gently thanks to our SoftSystem technology, which eliminates slamming even when shelves are fully loaded. Depending on the size of the Monolith unit, door hinges can hold up to 40 kg.

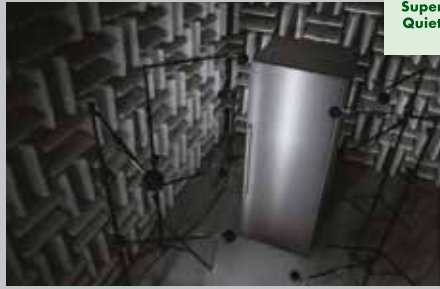

Super Quiet

SuperQuiet: Noise levels are kept to a minimum thanks to virtually silent, speed-controlled, and sound absorbing compressors. Alongside a low noise cooling circuit, these features ensure exact performance, energy efficiency, and SuperQuiet operation.



Bio Fresh-Plus

BioFresh-Plus: BioFresh technology offers you the perfect climate for superior, long-lasting food freshness. In addition to two BioFresh drawers, the third drawer in the Monolith fridge can be set to BioFresh-Plus by lowering temperatures down to -2°C, ideal for storing fresh fish and seafood.



Infinity Spring

InfinitySpring: The seamlessly integrated, flush-mounted InfinitySpring internal water dispenser is there when you need it, and also virtually invisible when you don't. This dispenser can accommodate water pitchers of any size. In addition our filtration system eliminates harmful contaminants, resulting in crisp, clear, fresh tasting water.



Infinity Light

InfinityLight: Seamlessly integrated LED side-wall lighting in the Monolith casts a beautiful and even glow that can be adjusted to your liking. It gives a soft, brightening effect upon opening the appliance doors and comes with a pleasing night dimming feature. InfinityLight adds drama and flair while emitting less heat to preserve food quality.



Infinity Swipe

InfinitySwipe: The Monolith's intuitive electronic touch-control panel features a full-colour 3.5-inch touch and swipe screen that's bright, clean, and wonderfully user-friendly. You'll barely have to lift a finger to control every function.

Optional Accessories

Stainless steel fronts

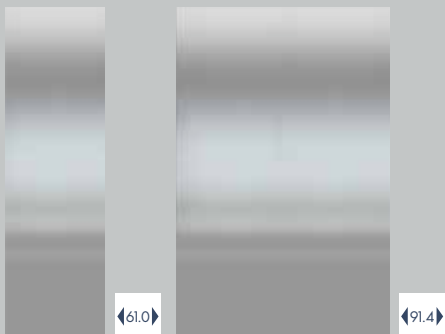

61.0

91.4

Stainless steel front 61.0 cm
(Part no. 39901883)

Stainless steel front 91.4 cm
(Part no. 39901458)

Handle variants



Brushed aluminium square handle
(Part no. 39901461)

Round stainless steel handle
(Part no. 39901489)

Brushed aluminium soft-edge handle
(Part no. 39901492)

Stainless steel toe kicks



Stainless steel toe kick
Base - trim / 61.0 cm (Part no. 39901496)

Stainless steel toe kick
Base - trim / 91.4 cm (Part no. 39902349)

Stainless steel toe kick
Base - trim / 152.4cm (Part no. 39902366)

Side-by-Side kit

Monolith's Side-by-Side kit (Part no. 39901428) includes a side wall heater to prevent condensation, metal brackets with screws, and a finishing strip to fill the gap between the appliances.

Product Dimensions

61.0 cm appliance

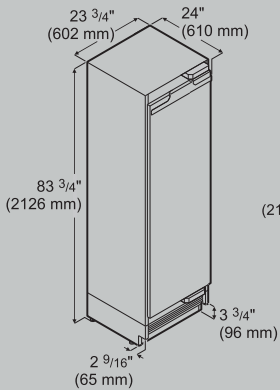

91.4 cm appliance

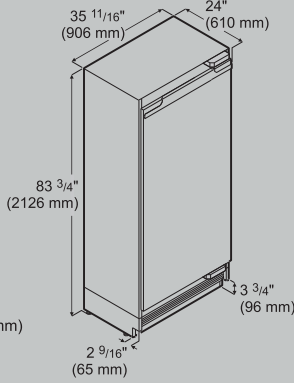

IMPORTANT!
Stated minimum height dimensions include height of the adjustable feet when fully inserted.

Height can be increased by a maximum of 19 mm by turning the adjustable feet. When the appliance is fitted in the recess, the appliance must be raised by turning the adjustable feet so that the appliance top has contact with the anti-tipping bracket. This results in a 4" (102 mm) toe kick height.

60.0 cm appliance

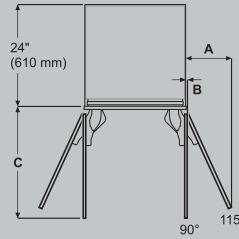

Internal door panel
 A = 10 3/4" (273 mm)
 B = 1/2" (12.5 mm)
 C = 25 7/8" (658 mm)

External door panel
 A = 11" (279 mm)
 B = 1/2" (12.5 mm)
 C = 26 3/8" (670 mm)

91.4 cm appliance

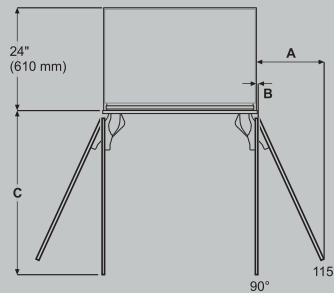

Internal door panel
 A = 15 3/4" (400 mm)
 B = 1/2" (12.5 mm)
 C = 37 7/8" (962 mm)

External door panel
 A = 16" (406 mm)
 B = 1/2" (12.5 mm)
 C = 38 3/8" (975 mm)

Dimension A = without mounted door handle

Cut Out Dimensions

Continuous toe kick

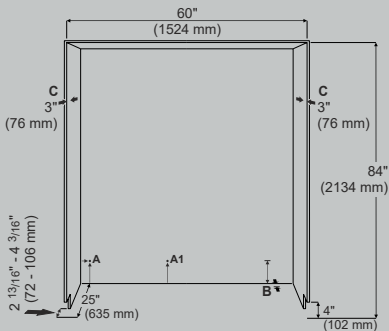

Individual toe kick

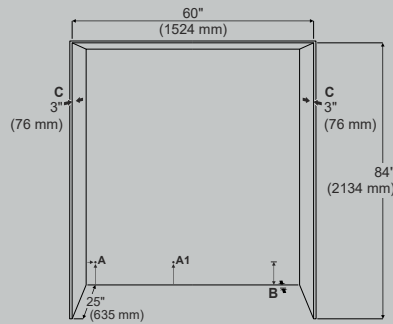

A: This is where the power cord exits the appliance rear, 3/4" (19 mm) from the left and 5" (127 mm) from the floor. Free length of the power cord is 98" (2.5 m). Power outlet is recommended to be placed outside of the appliance opening. A power supply of 220-240V with circuit grounded and protected by a circuit breaker is required. Socket must be properly earthed and protected by a fuse of 15A or 20A.

B: The appliance has a recess here for cable and waterline laying, 1" (25 mm) in depth and 5 1/2" (140 mm) in height over the whole width of the appliance. With the water filter installed, the pressure must be 40-90 psi. Without the water filter installed, the acceptable pressure is 22-87 psi. A shut-off valve must be installed between the water line and the main water supply, and must be easily accessible so that water supply can be stopped immediately if necessary.

C: This surface will be visible when the appliance door is open hence designed finish is required.

Door Front Dimensions



61.0 cm recess

Integrated installation

H = 79 7/8" (2029 mm)
 W = 23 3/4" (603 mm)

Frameless installation

H = 80" (2032 mm)
 Add overlapping dimension to the panel on the top.
 W = 24" (610 mm)
 Add overlapping dimension to the panel on both sides.

Front thickness = min. 5/8" (16 mm) / max. 1 3/8" (30 mm)
 Front and handle weight = max. 30 kg

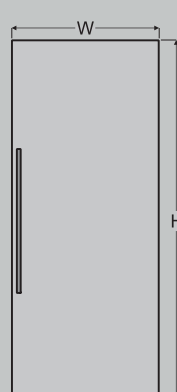

91.4 cm recess

Integrated installation

H = 79 7/8" (2029 mm)
 W = 35 3/4" (908 mm)

Frameless installation

H = 80" (2032 mm)
 Add overlapping dimension to the panel on the top.
 W = 36" (914 mm)
 Add overlapping dimension to the panel on both sides.

Front thickness = min. 5/8" (16 mm) / max. 1 3/8" (30 mm)
 Front and handle weight = max. 40 kg