

Fresh On The Inside,  
Sleek On The Outside

Quality, Design and Innovation

SIKB 3550

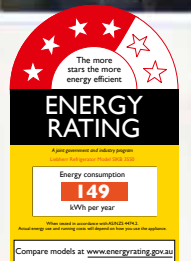

# LIEBHERR



**SoftSystem:** In built-in appliances, SoftSystem technology allows doors to close automatically and gently from 30° to eliminate slamming even when fully loaded.



**Door-on-door technology:** Allows custom panels to be affixed directly onto the appliance door so that the hinges are concealed, plus the cabinet and the fridge open as one, ensuring a wide range of design options and easy installation.



**BioFresh:** BioFresh guarantees the perfect temperature and ideal humidity for much longer freshness. While the DrySafe is perfect for meat, fish, and dairy products, the high humidity in the Fruit & Vegetable-Safe can prevent fruit and vegetables from drying out and helps preserve stored goods for an even longer period.

Hidden away behind custom cabinetry, Liebherr's fully integratable **SIKB 3550** is the perfect refrigerator for any kitchen. BioFresh technology keeps meat, fish, and dairy products fresh in the DrySafe compartment, while high humidity in the Fruit & Vegetable-Safe efficiently retains natural moisture in unpackaged fruits and vegetables. The practical FlexSystem ensures neat separation and clear sorting. This model features efficient LED lighting throughout and flexible bottle racks to maximise interior space. SoftSystem technology ensures the gentle closing of doors even when shelves are fully loaded.

**SIKB 3550**  
Premium

- Bio Fresh
- Soft System
- Soft Telescopic

Energy consumption (kWh/yr)   Star rating	149   4.0
Compressors	1
Total Usable Litres	306
Refrigerator Usable Litres	212
BioFresh Usable Litres	94
MagicEye control system   Display	SoftTouch   LCD
Child proof setting for display & temperature	•
Premium lighting	•
SoftSystem hinge - assists closure	•
Door open warning signal   Malfunction warning signal	•   •
Optional extra stainless steel panel & handle	•
BioFresh drawers on telescopic rails	3
SuperCool	•
GlassLine shelves	•
VarioSafe	•
Elegant holding columns	•
Bottle shelf   Egg tray	Integrated   •
Automatic refrigerator defrosting	•
Door hinges	Right, reversible
Voltage (V)   Rated Current (A)	220-240   1.2
Made in	Germany

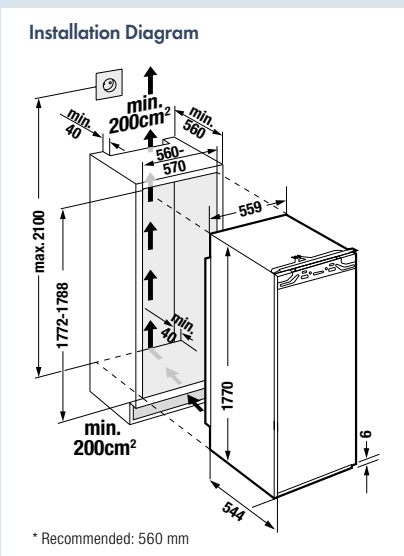

*Note: Whilst every effort is made to ensure all specifications and information in this flyer are accurate, Liebherr reserves the right to make changes without notification. Where actual appliance measurements, specifications, and ratings are crucial, we recommend that the actual appliance installation instructions that accompany each appliance be checked. Liebherr will not be liable for any loss.*

Subject to modification. Current data see home.liebherr.com.au (021221)