

Practicality And Elegance For Your Kitchen

Quality, Design and Innovation

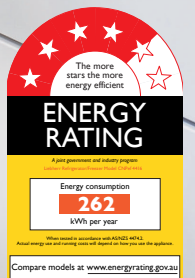

CNPef 4416



LIEBHERR



VarioSpace: Nearly all freezers include drawers and glass shelves that can be conveniently removed to create extra storage space. It's Liebherr's very practical solution to quickly accommodate even bulky items.



Touch control system: Our intuitive electronic touch control panel ensures all functions are easy and convenient to use as well as guarantees that the settings selected remain accurate and constant.



SmartSteel: With SmartSteel used on the appliance door the visibility of fingerprints is reduced, making it very easy to clean. Maintain this beautiful door exterior simply with a wipe of a clean, dry or damp cloth.

The compact fridge-freezer combination **CNPef 4416** is the perfect choice for smaller footprint installations like galley kitchens or apartment living. It includes smart interior design features like a beverage rack, foldable glass shelf, and a stainless back wall which prevents ice build-up and dripping.

The SmartSteel door is scratch resistant and makes fingerprints virtually disappear – one wipe of a cloth is all it takes to keep the surface clean. The **CNPef 4416** can be paired with itself with the help of our optional side by side kit for even more fridge and freezer space.

CNPef 4416
Comfort

| | | |
|----------|-------------|-------------|
| No Frost | Duo Cooling | Smart Steel |
|----------|-------------|-------------|

| | |
|--|--------------------------|
| Energy consumption (kWh/yr) Star rating | 262 4.5 |
| Compressors | 1 |
| Total Usable Litres | 368 |
| Refrigerator Usable Litres | 279 |
| Freezer Usable Litres | 89 |
| Control system Display | Touch-Electronic LCD |
| Child proof setting for display & temperature | • |
| LED standard lighting | • |
| DuoCooling | • |
| Sabbath mode | • |
| Handle Integrated opening device | 3/4" stainless steel • |
| Temp alarm Malfunction warning signal Door open warning signal | • • • |
| Fruit & vegetable drawer on telescopic rails | 2 |
| SuperCool | • |
| GlassLine shelves | • |
| Elegant holding columns | • |
| Automatic refrigerator defrosting Freezer defrosting | • Frost Free |
| FrostSafe system with transparent drawers | • |
| Freezer drawers | 2 |
| SuperFrost | • |
| 24hr freezing capacity (kg) | 8 |
| Door hinges | Right, Reversible |
| Voltage (V) Rated Current (A) | 220-240 1.5 |
| Made in | Austria |

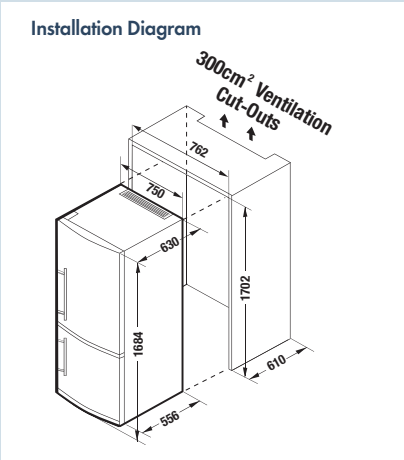

Note: Whilst every effort is made to ensure all specifications and information in this flyer are accurate, Liebherr reserves the right to make changes without notification. Where actual appliance measurements, specifications, and ratings are crucial, we recommend that the actual appliance installation instructions that accompany each appliance be checked. Liebherr will not be liable for any loss.