

Operating instructions

integrated fridge with BioFresh

EN

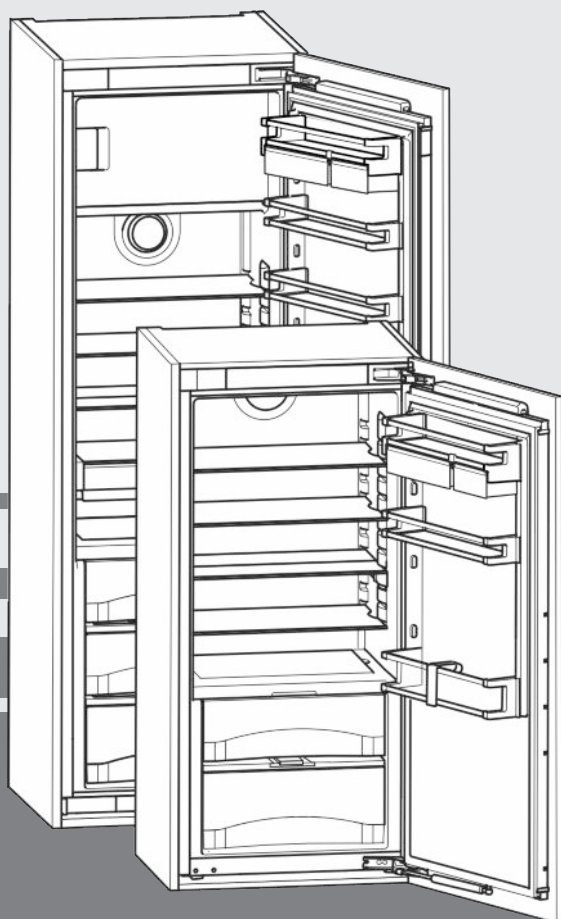

20190405 **7086518 - 01**

IKB/ IKBP

LIEBHERR

Contents

1	Appliance at a glance	2
1.1	Description of appliance and equipment.....	2
1.2	Appliance range of use.....	2
1.3	Conformity.....	3
1.4	Product data.....	3
1.5	Saving energy.....	3
2	General safety information	3
3	Controls and displays	4
3.1	Operating and control elements.....	4
3.2	Temperature display.....	4
4	Putting into operation	4
4.1	Switching on the appliance.....	4
5	Control	5
5.1	Child proofing.....	5
5.2	Door alarm.....	5
5.3	Refrigerator compartment.....	5
5.4	BioFresh compartment.....	7
5.5	Freezer compartment*.....	9
6	Maintenance	10
6.1	Defrosting.....	10
6.2	Cleaning the appliance.....	11
6.3	Customer service.....	11
7	Malfunctions	11
8	Decommissioning	12
8.1	Switching off the appliance.....	12
8.2	Taking the appliance out of service.....	12
9	Disposing of the appliance	12

The manufacturer works constantly on the further development of all the types and models. Therefore please understand that we have to reserve the right to make design, equipment and technical modifications.

To get to know all the benefits of your new appliance, please read the information contained in these instructions carefully.

The instructions apply to several models. Differences may occur. Text relating only to specific appliances is marked with an asterisk (*).

Instructions for action are marked with a ►, the results of action are marked with a ▷.

1 Appliance at a glance

1.1 Description of appliance and equipment

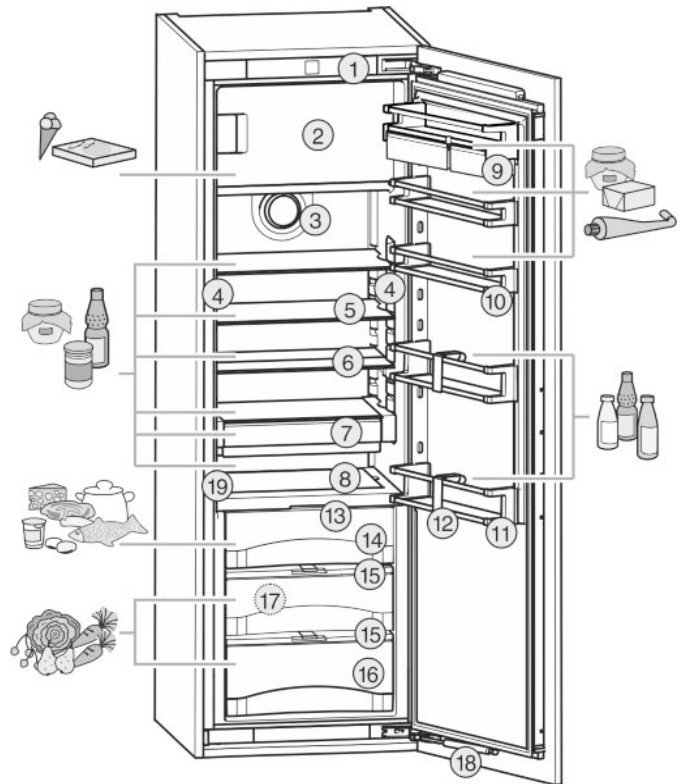

Fig. 1

- | | |
|------------------------------------|---|
| (1) Operating and control elements | (11) Bottle rack |
| (2) Freezer compartment* | (12) Bottle holder |
| (3) Fan | (13) LED lighting, BioFresh compartment |
| (4) LED light column, double sided | (14) DrySafe |
| (5) Shelf | (15) Fruit & Vegetable safe cover |
| (6) Shelf, sectioned | (16) Fruit & Vegetable safe |
| (7) VarioSafe* | (17) Drain hole |
| (8) Adjustable bottle shelf* | (18) Soft stop mechanism |
| (9) VarioBox | (19) Type plate |
| (10) Can rack | |

Note

- Place food inside the appliance as shown in the diagram. This allows the appliance to save energy during operation.
- Shelves, drawers and baskets are arranged for optimum energy efficiency on delivery.

1.2 Appliance range of use

Intended use

The appliance is only suitable for cooling food products in a domestic or household-like environment. This includes, for example, use:

- in staff kitchens, bed and breakfast establishments,
- by guests in country houses, hotels, motels and other accommodation,

- for catering and similar services in the wholesale trade.

All other types of use are not permitted.

Foreseeable misuse

The following applications are expressly forbidden:

- Storing and refrigerating medicines, blood plasma, laboratory preparations or similar substances and products based on the Medical Device Directive 2007/47/EC
- Use in areas at risk of explosions

Misusing the appliance may lead to damage to the goods stored or they may spoil.

Climate classifications

Depending on the climate classification the appliance is designed to operate in restricted ambient temperatures. The climate classification applying to your appliance is printed on the rating plate.

Note

- Keep to the specified ambient temperatures in order to guarantee that the appliance works properly.

Climate classification	for ambient temperatures of
SN	10 °C to 32 °C
N	16 °C to 32 °C
ST	16 °C to 38 °C
T	16 °C to 43 °C

1.3 Conformity

The refrigerant circuit has been tested for leaks. In installed condition, this appliance complies with the applicable safety stipulations and with directives 2014/35/EU, 2014/30/EU, 2009/125/EG, 2011/65/EU and 2010/30/EU.

The BioFresh compartment satisfies the requirements for a cold storage compartment in acc. with DIN EN 62552.

1.4 Product data

Product data is included with the appliance, as per Directive (EU) 2017/1369. The complete product data sheet is available on the Liebherr website under Downloads.

1.5 Saving energy

- Pay attention to good ventilation. Do not cover ventilation holes or grids.
- Always keep the fan air slits clear.
- Do not install the appliance in direct sunlight, next to an oven, radiator or similar.
- Energy consumption is dependent on the installation conditions, e.g. ambient temperature (see 1.2) . If the ambient temperature deviates from the standard temperature of 25°C, the energy consumption may differ.
- Open the appliance for as short a time as possible.

- The lower the temperature is set the higher the energy consumption.
- Arrange the food in an organised way (see 1) .
- Keep all food properly packed and covered. This prevents frost from forming.
- Only take food out for as long as necessary so that it doesn't warm up too much.
- Inserting warm food: allow to cool down to room temperature first.
- Thaw frozen food in the refrigerator.*
- If there is a thick layer of frost in the appliance: defrost the appliance.*
- If you intend to be on holiday for a long time empty the refrigerator and switch it off.

2 General safety information

Danger for the user:

- This device can be used by children and people with impaired physical, sensory or mental abilities or with a lack of experience and knowledge provided that they are supervised or have received instruction in the safe use of this device, and about the resulting hazards. Children must not play with this appliance. Cleaning and user maintenance work must not be carried out by children without adult supervision. Children aged between 3 and 8 are allowed to load and unload the appliance. Children below the age of 3 must be kept away from the appliance unless they are under continuous adult supervision.
- When disconnecting the appliance from the supply, always take hold of the plug. Do not pull the cable.
- In the event of a fault pull out the mains plug or deactivate the fuse.
- Do not damage the mains power cable. Do not operate the appliance with a defective mains power cable.
- Repairs, interventions on the appliance and the replacement of mains connection line may only be carried out by After-Sales Service or other suitably trained specialist personnel.
- Only install, connect and dispose of the appliance according to the instructions.
- Only use the appliance when it is installed.
- Please keep these instructions in a safe place and pass them on to any subsequent owners.
- Special lights, such as LED lights on the appliance, are used to illuminate the interior of the appliance and are not suitable for room lighting.

Fire hazard:

- The coolant used (information on the model plate) is eco-friendly but also flammable. Any leaking coolant may ignite.
 - Do not damage the refrigerant circuit pipes.

Controls and displays

- Do not use an open flame or other source of ignition inside the appliance.
- Do not use electrical appliances inside the appliance (e.g. steam cleaners, heaters, ice cream makers, etc.).
- If the refrigerant leaks: remove any naked flames or ignition sources from the vicinity of the leakage point. Properly air the room. Inform customer services.
- Do not store explosives or sprays using combustible propellants such as butane, propane, pentane, etc. in the appliance. To identify these spray cans, look for the list of contents printed on the can, or a flame symbol. Gases possibly escaping may ignite due to electrical components.
- Please be sure to store alcoholic drinks or other packaging containing alcohol in tightly closed containers. Any alcohol that leaks out may be ignited by electrical components.

Danger of tipping and falling:

- Do not misuse the plinth, drawers, doors etc. as a step or for support. This applies particularly to children.

Danger of food poisoning:

- Do not consume food which has been stored too long.

Danger of frostbite, numbness and pain:

- Avoid lasting skin contact with cold surfaces or refrigerated/frozen food or take protective steps, e.g. wear gloves. Do not consume ice cream, water ice or ice cubes immediately and do not consume them too cold.



Danger of injury and damage:

- Hot steam can lead to injury. Do not use electrical heating or steam cleaning equipment, open flames or defrosting sprays to defrost.
- Do not use sharp implements to remove the ice.



Danger of crushing:

- Do not hold the hinge when opening and closing the door. Fingers may get caught.

Symbols on the appliance:

	The symbol can be located on the compressor. It refers to the oil in the compressor and indicates the following danger: Swallowing or inhaling can be fatal. This is only relevant for recycling. There is no danger in normal operation.
	A sticker to this effect may be applied to the rear of the appliance. It refers to the foam-padded panels in the door and/or the housing. This is only relevant for recycling. Do not remove the sticker.

Please observe the specific information in the other sections:

	DANGER	identifies a situation involving direct danger which, if not obviated, may result in death or severe bodily injury.
	WARNING	identifies a dangerous situation which, if not obviated, may result in death or severe bodily injury.
	CAUTION	identifies a dangerous situation which, if not obviated, may result in minor or medium bodily injury.
	NOTICE	identifies a dangerous situation which, if not obviated, may result in damage to property.
	Note	identifies useful information and tips.

3 Controls and displays

3.1 Operating and control elements

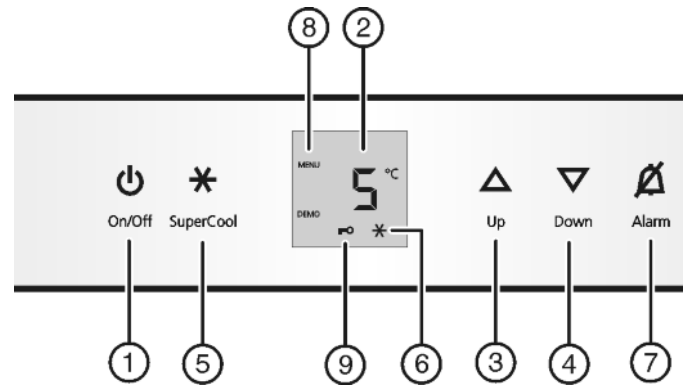

Fig. 2

- (1) On/Off button
- (2) Temperature display
- (3) Up setting button
- (4) Down setting button
- (5) SuperCool button
- (6) SuperCool symbol
- (7) Alarm button
- (8) Menu symbol
- (9) Child lock symbol

3.2 Temperature display

During normal operation, the display shows:

- the average cooling temperature

The following displays indicate a fault. Possible causes and solutions: (see 7) .

- F0 to F9

4 Putting into operation

4.1 Switching on the appliance

Switch on the appliance approx. 2 hours before loading for the first time.*

- ▶ Open the door.
- ▶ Press On/Off button Fig. 2 (1).
- ▷ The temperature display indicates the current temperature.
- ▷ The interior light is on when the door is open.
- ▷ If "DEMO" is displayed, demo mode is activated. Please contact the after sales service.

5 Control

5.1 Child proofing

The child-proofing function enables you to make sure that the appliance is not inadvertently switched off by playing children. 

5.1.1 Setting the child lock function

- ▶ Activate setting mode: Press the SuperCool button *Fig. 2 (5)* for around 5 seconds.
- ▷ The display indicates **c**.
- ▶ Briefly press the SuperCool button *Fig. 2 (5)* to confirm. When **cl** is indicated in the display: 
- ▶ to activate the child lock, briefly press the SuperCool button *Fig. 2 (5)*.

- ▷ The child lock symbol *Fig. 2 (9)* shines. **c** flashes in the display. When **cl** is indicated in the display:
 - ▶ to deactivate the child lock, briefly press the SuperCool button *Fig. 2 (5)*.
- ▷ The child lock symbol *Fig. 2 (9)* goes out. **c** flashes in the display.
- ▶ To deactivate the set-up mode: press On/Off button *Fig. 2 (1)*.
- or-
- ▶ Wait for 5 minutes.
- ▷ The temperature is indicated again in the temperature display.

5.2 Door alarm

For the fridge and BioFresh compartments
An audible warning sounds if the door is open for longer than 60 seconds.

The audible warning stops automatically when the door is closed. 

5.2.1 Muting the door alarm

The audible alarm can be muted when the door is open. The sound switch-off function is active as long as the door is left open.

- ▶ Press alarm button *Fig. 2 (7)*.
- ▷ The door alarm is silenced.

5.3 Refrigerator compartment

The natural circulation of air in the refrigerator compartment results in zones differing in temperature. It is coldest directly above the plate separating off the BioFresh zone and at the rear wall. It is warmest at the top front of the compartment and in the door.

5.3.1 Food refrigeration

- ▶ Place butter and preserves in the upper area and in the door (see 1).
- ▶ Use recyclable plastic, metal, aluminium and glass containers and cling film for wrapping.
- ▶ Always store liquids and food which is subject to odour or taste transfer in closed containers or cover them.

- ▶ Use the front area of the refrigerator compartment floor only for briefly putting down cooled products, e.g. when rearranging and sorting. However do not leave cooled products there otherwise they may be pushed back or tipped over when the door is closed.
- ▶ Do not store food too close together to enable good air circulation.

5.3.2 Setting the temperature

The temperature depends on the following factors:

- the frequency of opening the door
- the room temperature of the installation location
- the type, temperature and quantity of the food

The temperature can be set from 9 °C to 3 °C, the recommended temperature is 5 °C.

An average temperature of about -18 °C is reached in the freezer compartment.*

Note

If the temperature is to be colder than 3 °C:

- ▶ set the cooling temperature to 3 °C.
 - ▶ Set the BioFresh temperature to a value between **b4** (slightly colder) and **bl** (coldest) (see 5.4).
-
- ▶ For a higher temperature setting: press Up button *Fig. 2 (3)*.
 - ▶ For a lower temperature setting: press Down button *Fig. 2 (4)*.
 - ▷ When the button is pressed the first time, the previously set value is indicated, flashing, in the temperature display.
 - ▶ To change the temperature in 1 °C steps: briefly press the button.
 - ▶ To change the temperature continuously: hold down the button.
 - ▷ The value is displayed flashing during the setting operation.
 - ▷ The actual temperature is displayed about 5 s after the last press of a button. The temperature slowly adjusts to the new value.

5.3.3 SuperCool

With SuperCool you switch to the highest cooling performance to reach lower cooling temperatures. Use SuperCool, to rapidly cool large amounts of food. 

When SuperCool is activated, the fan* may run. The appliance operates with maximum cooling performance, which means that the noise of the refrigeration unit may be temporarily louder.

The SuperCool function uses slightly more energy.

Cooling with SuperCool

- ▶ Briefly press SuperCool button *Fig. 2 (5)*.
- ▷ The SuperCool symbol *Fig. 2 (6)* lights up in the display.
- ▷ The cooling temperature drops to the coldest value. SuperCool is activated.
- ▷ SuperCool is automatically deactivated after 12 hours. The appliance continues to operate in the energy-saving, normal mode.

To prematurely deactivate SuperCool

- ▶ Briefly press SuperCool button *Fig. 2 (5)*.
- ▷ The SuperCool symbol *Fig. 2 (6)* goes out in the display.
- ▷ SuperCool is deactivated.

5.3.4 Shelves

Moving or removing shelves

The shelves are prevented from being pulled out accidentally by pull out stops.

Control

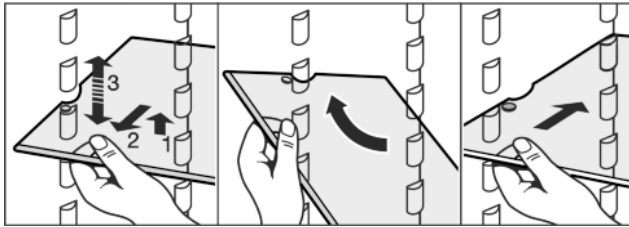
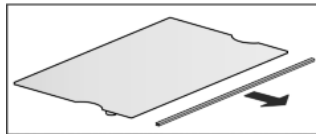

Fig. 3

- ▶ Lift the shelf and pull forward a little.
- ▶ Adjust the height of the shelf. To do this move the slots along the supports.
- ▶ Only a short shelf may be inserted in front of the fan. *
- ▶ In order to remove the shelf fully, place it at a slant and pull out towards the front.
- ▶ Re-insert shelves at the required height. The stops must face downwards and lie behind the front shelves.

Dismantling shelves

- ▶ The shelves can be dismantled for cleaning.



5.3.5 Using the sectioned shelf

- ▶ Slide the sectioned shelf under, as shown in the illustration.

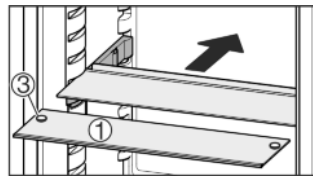
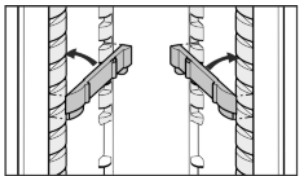
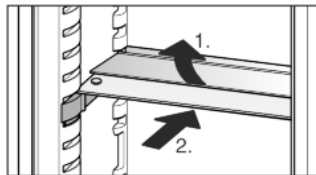

Fig. 4

- ▶ The glass plate (1) with pull-out stops must be at the front so that the stops (3) face downwards.
- ▶ When dealing with appliances with a freezer compartment, do not attach trayslides and sectioned shelves in front of the fan. *

5.3.6 Using adjustable bottle shelf*

At the base of the refrigerator compartment, the integrated bottle shelf or alternatively the glass shelf can be used:

- ▶ Using the bottle shelf: to save space, store the glass shelf under the bottle shelf.
- ▶ Place the bottles with the base pointing backwards facing the rear wall.
- ▶ If the bottles project beyond the bottle shelf:
- ▶ set the lower door rack one position higher.

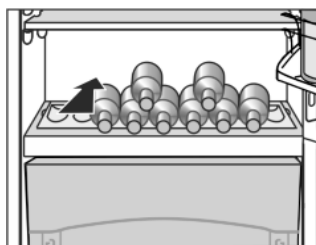

5.3.7 VarioSafe*

The VarioSafe provides space for small items of food and packages, tubes and jars.

Using VarioSafe*

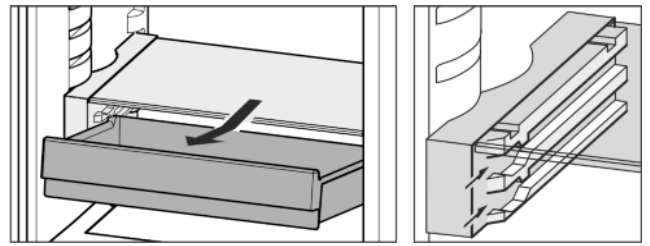
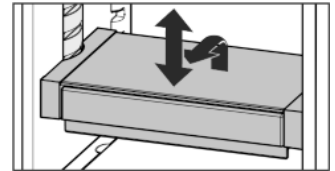

Fig. 5

- ▶ The VarioSafe drawer can be taken out and pushed in at two different heights.
- ▶ The VarioSafe can also be height-adjusted as a whole.
- ▶ To remove them completely, set them at an angle and pull towards you.



Dismantling VarioSafe*

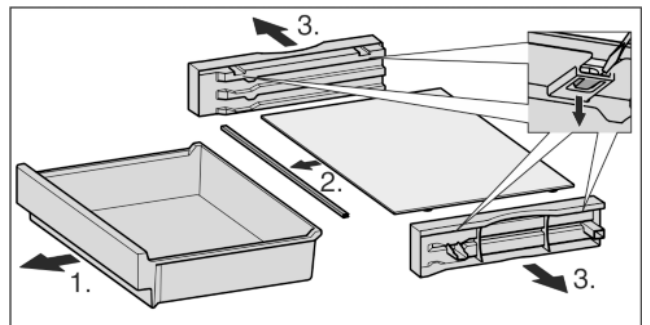

Fig. 6

- ▶ The VarioSafe can be dismantled for cleaning.

5.3.8 Door racks

Moving the storage rack

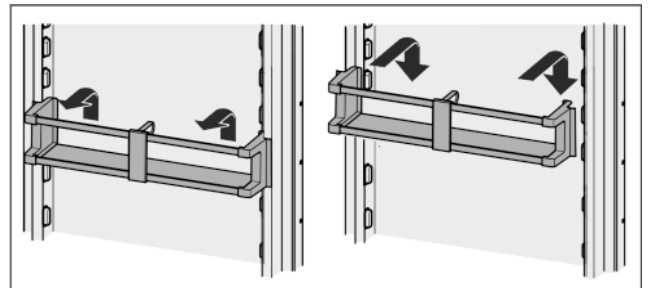

Fig. 7

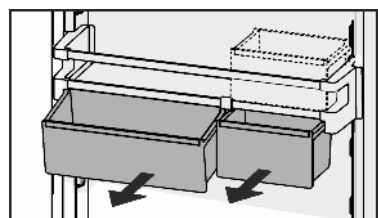
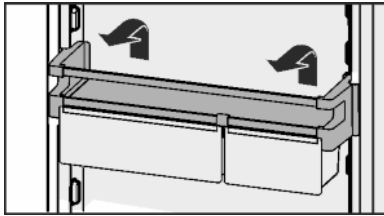

Fig. 8

You can use just one or both boxes. To store oversized bottles, just suspend one box over the bottle rack. Store the other box in the holder.

- ▶ Re-positioning the boxes: Lift them for removal and re-position them as required.



Dismantling door racks

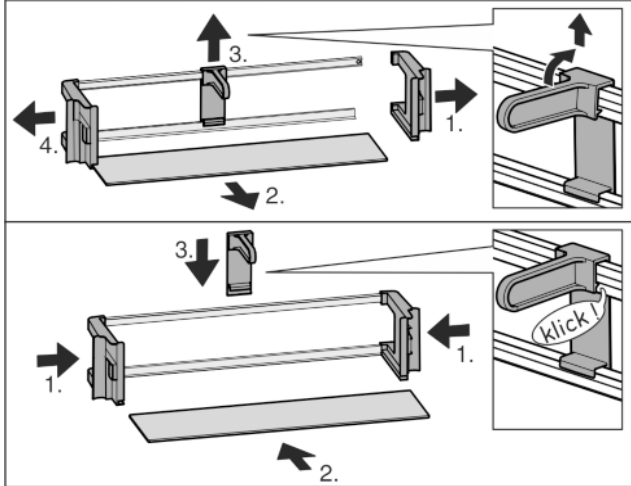

Fig. 9

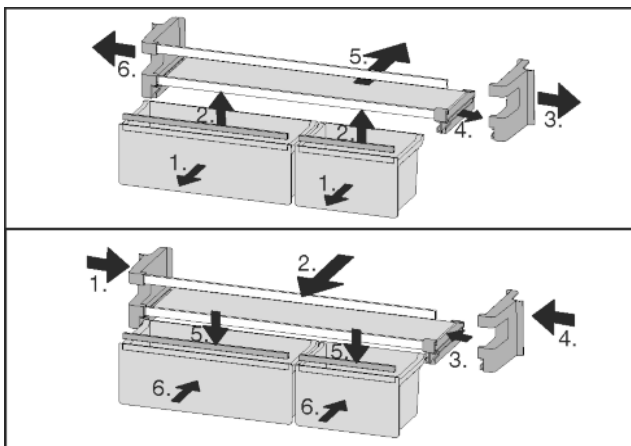
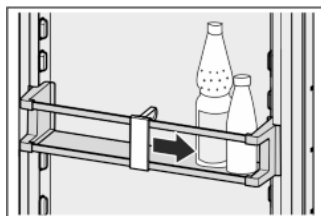

Fig. 10

- ▶ The door racks can be dismantled for cleaning.

5.3.9 Using the bottle holder

- ▶ To avoid the bottles tipping over, push the bottle holder along.



5.3.10 Butter dish

Opening/closing the butter dish

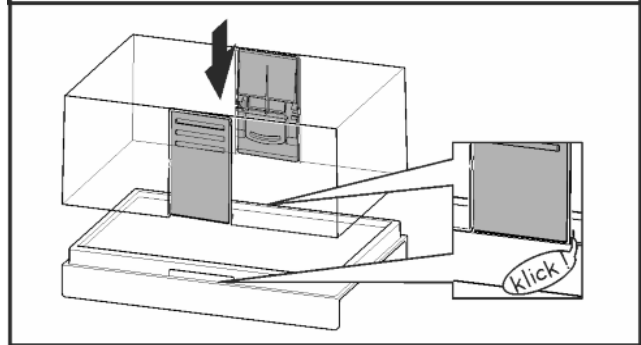
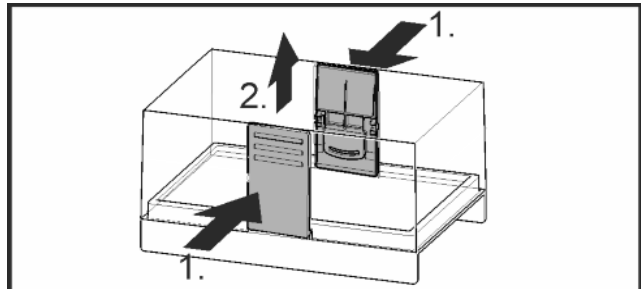

Fig. 11

Dismantling the butter dish

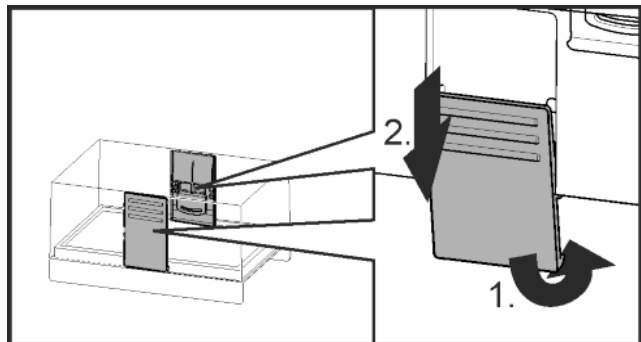
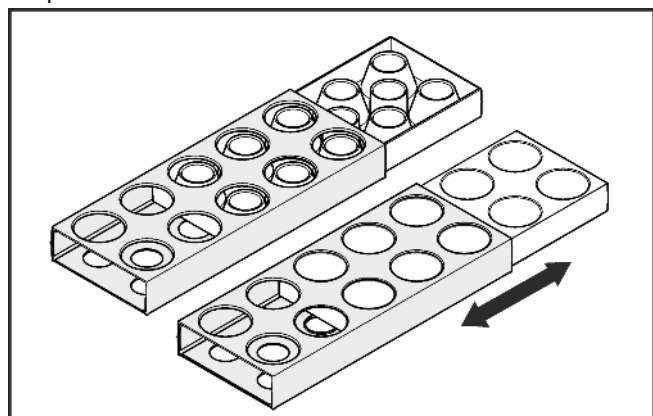

Fig. 12

- ▶ You can take the butter dish apart for cleaning.

5.3.11 Egg tray

You can take out and rotate the egg tray. You can use the two parts of the egg tray to mark different use-by dates, for example.



- ▶ Use the top part to store e.g. chicken eggs.
- ▶ Use the bottom part to store quails' eggs.

5.4 BioFresh compartment

In the BioFresh section, certain fresh foods can be kept fresh for longer compared to conventional cooling methods.

For food with an indicated best before date, the date specified on the packaging always applies.

Control

If the temperature falls below 0 °C, foodstuffs can freeze.

5.4.1 DrySafe

The DrySafe is suitable for storing dry or wrapped food (e.g. dairy products, meat, fish, sausages). A relatively dry storage climate is established here.

5.4.2 Fruit & Vegetable safe

The humidity in the Fruit & Vegetable safe depends on the moisture content of the items being stored and the number of times the door is opened. You can set the humidity yourself.

On the high moisture setting, the Fruit & Vegetable safe is suitable for storing loose salad, vegetables and fruit with a high moisture content. A well-stocked drawer is stored in absolute freshness.

5.4.3 Setting the moisture level in the Fruit & Vegetable safe

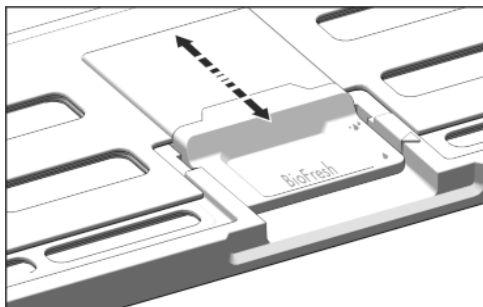



Fig. 13

You can choose any moisture setting for the Fruit & Vegetable safe.

- ▶  Low humidity: Slide the slide bar backwards.
- ▷ The openings in the cover are partially or fully open. The moisture levels drop in the Fruit & Vegetable safe.
- ▶  High humidity: Slide the slide bar forwards.
- ▷ The openings in the cover are partially or fully closed. The moisture levels rise in the Fruit & Vegetable safe.

5.4.4 Storing food

Note

- ▶ Do not put the following in the BioFresh section: cold-sensitive vegetables including cucumbers, aubergines, tomatoes, courgettes and any cold-sensitive tropical fruits.
- ▶ To prevent food spoilage due to transfer of germs: Store unwrapped animal and vegetable products separate from one another in the drawers. This also applies to different sorts of meat.
If food has to be stored together due to lack of space:
 - ▶ wrap the food.
 - ▶ Storing high-moisture content foods: shake off the moisture beforehand.
 - ▶ If there is too much moisture in the compartment:
 - ▶ select the low moisture setting.
- or-
- ▶ Remove any excess moisture with a cloth.

5.4.5 Storage times

Guidelines for storage periods at low humidity 0 °C			
Butter	up to	90	days
Hard cheese	up to	110	days
Milk	up to	12	days

Guidelines for storage periods at low humidity 0 °C			
Cold meats	up to	9	days
Poultry	up to	6	days
Pork	up to	7	days
Beef	up to	7	days
Game	up to	7	days

Note

- ▶ Please note that protein-rich food deteriorates faster, i.e. shellfish and crustaceans deteriorate faster than fish, fish faster than meat.

Guidelines for storage periods at high humidity 0 °C			
Vegetables, salads			
Artichokes	up to	14	days
Celery	up to	28	days
Cauliflower	up to	21	days
Broccoli	up to	13	days
Chicory	up to	27	days
Leaf lettuce	up to	19	days
Peas	up to	14	days
Kale	up to	14	days
Carrots	up to	80	days
Garlic	up to	160	days
Cabbage	up to	55	days
Round lettuce	up to	13	days
Herbs	up to	13	days
Leeks	up to	29	days
Mushrooms	up to	7	days
Radishes	up to	10	days
Sprouts	up to	20	days
Asparagus	up to	18	days
Spinach	up to	13	days
Savoy cabbage	up to	20	days
Fruit			
Apricots	up to	13	days
Apples	up to	80	days
Pears	up to	55	days
Blackberries	up to	3	days
Dates	up to	180	days
Strawberries	up to	7	days
Figs	up to	7	days
Blueberries	up to	9	days
Raspberries	up to	3	days
Red currants	up to	7	days
Cherries, sweet	up to	14	days
Kiwis	up to	80	days
Peaches	up to	13	days

Guidelines for storage periods at high humidity 0 °C			
Plums	up to	20	days
Cranberries	up to	60	days
Rhubarb	up to	13	days
Gooseberries	up to	13	days
Grapes	up to	29	days

5.4.6 Adjusting the temperature in the BioFresh compartment

Recommended refrigerator setting: 5 °C. The BioFresh temperature is controlled automatically and is between 0 °C and 3 °C.

You can set a slightly higher or lower temperature. The temperature can be adjusted between **b1** (coldest temperature) and **b9** (hottest temperature) The default is **b5**. With levels **b1** to **b4** the temperature may drop below 0 °C so that the food can freeze.

► To activate the setting mode: press the SuperCool button *Fig. 2 (5)* for about 5 s.

▷ The menu symbol *Fig. 2 (8)* shines. The temperature display indicates **c**.

► Press the Up setting button *Fig. 2 (3)* the number of times required for **b** to flash in the display.

► To confirm: briefly press the SuperCool button *Fig. 2 (5)*.

► For a warmer temperature adjustment: press Up setting button *Fig. 2 (3)*.

► For a colder temperature adjustment: press Down setting button *Fig. 2 (4)*.

► To confirm: press SuperCool button *Fig. 2 (5)*.

▷ The temperature slowly adjusts to the new value.

► To deactivate the setting mode: press the On/Off button *Fig. 2 (1)*.

-or-

► Wait for 5 minutes.

▷ The temperature is indicated again in the temperature display.

5.4.7 Drawers with cushioners

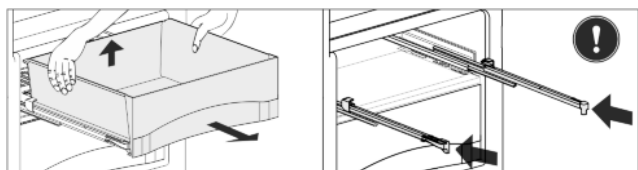

Fig. 14

► Pull out the drawer, lift it at the back and draw it forwards for removal.

► Push the rails in again!

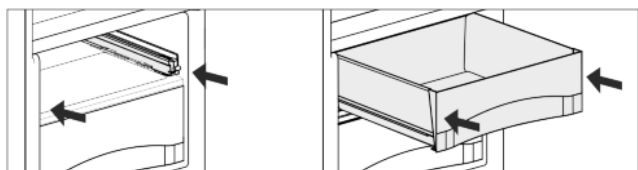

Fig. 15

► Push the rails in.

► Attach the drawer and push it in until it engages audibly at the back.

5.4.8 Fruit & Vegetable safe cover

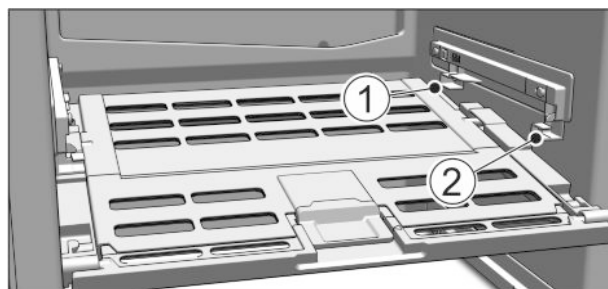

Fig. 16

► Removing the Fruit & Vegetable safe cover: After pulling out the drawers, carefully pull the cover towards you and down.

► Replacing the Fruit & Vegetable safe cover: Guide the ridges on the cover into the rear brackets *Fig. 16 (1)* and click it into the front bracket *Fig. 16 (2)*.

5.4.9 Using the FlexSystem

The FlexSystem helps you store and organise your food in a clear and flexible way. It lets you clearly divide your food into fruit, vegetables or by use-by dates, for example.

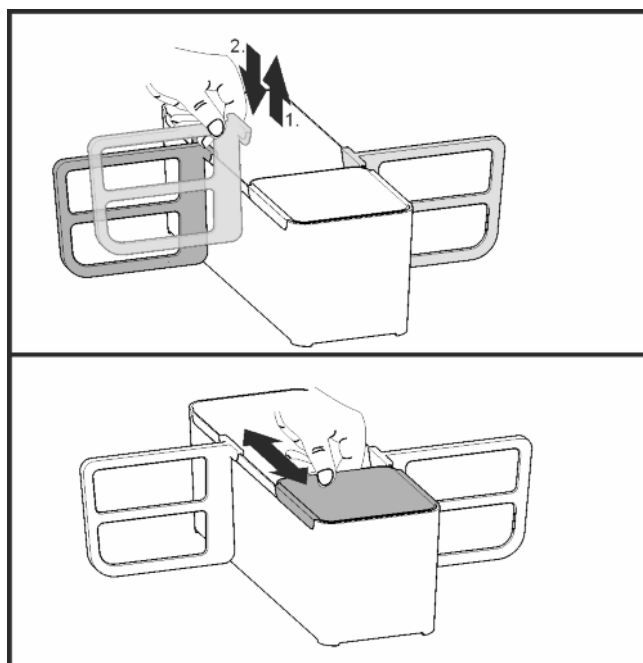

Fig. 17

► You can take the FlexSystem apart for cleaning.

5.5 Freezer compartment*

You can store frozen food for several months, make ice cubes and freeze fresh food in the freezer compartment at a temperature of -18 °C and lower.

The air temperature in the compartment, measured by thermometer or other instruments, may fluctuate.

5.5.1 Freezing food

The rating plate indicates the maximum quantity of fresh food you can freeze within 24 hours (see 1) under "Freezing capacity ... kg/24h".

Maintenance



CAUTION

Risk of injury due to broken glass!
Bottles and cans containing drinks may burst when being frozen. This applies particularly to sparkling drinks.

► Do not freeze bottles and cans containing drinks!

► Switch on SuperCool when you load the product (see 5.3.3).

So that the food is rapidly frozen through to the core, do not exceed the following quantities per pack

- Fruit, vegetables up to 1 kg
- Meat up to 2.5 kg
- Pack the food in portions in freezer bags, reusable plastic, metal or aluminium containers

5.5.2 Storage times

Guide times for storing various types of food in the freezer compartment:	
Ice cream	2 to 6 months
Sausage, ham	2 to 6 months
Bread, bakery products	2 to 6 months
Game, pork	6 to 10 months
Fish, fatty	2 to 6 months
Fish, lean	6 to 12 months
Cheese	2 to 6 months
Poultry, beef	6 to 12 months
Vegetables, fruit	6 to 12 months

Storage times given are guide times.

5.5.3 Thawing food

- in the refrigerator compartment
- in a microwave oven
- in a conventional or fan oven
- at room temperature
- Remove only as much food as is required. Use thawed food as quickly as possible.
- Food once thawed should be re-frozen only in exceptional cases.

5.5.4 Ice cube tray*

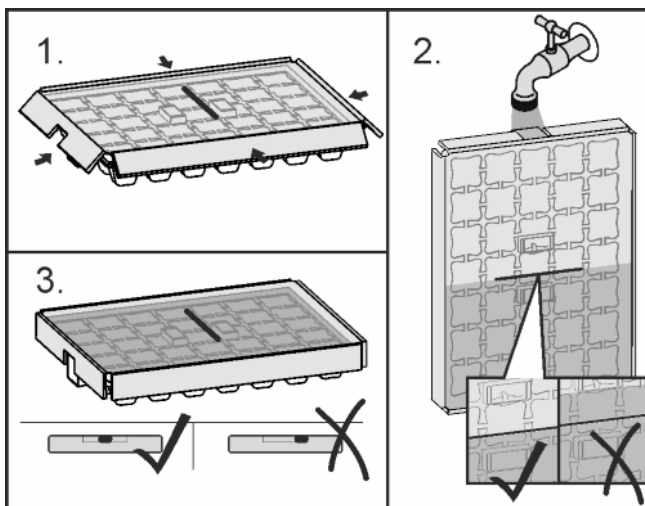

Fig. 18

When the water is frozen:

► Hold ice cube tray under hot water for a short time.

- Remove the lid.
- Gently turn the ends of the ice cube tray in opposite directions and release the cubes.

Dismantling the ice cube tray

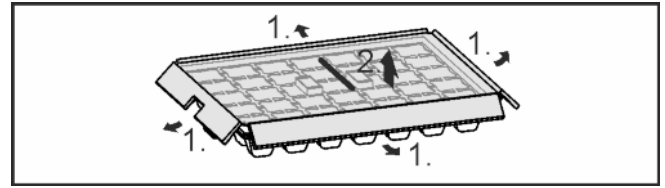

Fig. 19

► You can take the ice cube tray apart for cleaning.

6 Maintenance

6.1 Defrosting

6.1.1 Defrosting refrigerator compartment

The refrigerator compartment is defrosted automatically. The water evaporates. Drops of water on the rear wall are functionally conditioned and perfectly normal.

► Clean the drain hole at regular intervals to allow the defrost water to drain (see 6.2).

6.1.2 Defrosting freezer compartment*

A layer of frost and ice forms in the freezer compartment after the appliance has been in use for a lengthy period of time. This is quite normal. The layer of frost and ice forms more quickly if the door is opened frequently or if the food is warm when placed inside. However, a thick layer of ice will increase the appliance's energy consumption. You should therefore defrost the appliance regularly.



WARNING

Danger of injury and damage

- Do not use any mechanical aids or other means not recommended by the manufacturer in order to accelerate the defrosting process.
- Do not use electrical heating or steam cleaning equipment, open flames or defrosting sprays to defrost.
- Do not use sharp implements to remove the ice.
- Do not damage the pipework in the refrigerant circuit.

- Switch off the appliance.
- ▷ The temperature display goes out.
- ▷ If the temperature display does not go out, the child-proofing function (see 5.1) is active.
- Pull out the plug.
- Wrap the frozen food in newspaper or blankets and store in a cool place.
- Leave the compartment and appliance door open during defrosting.
- Remove detached pieces of ice.
- Pay attention that the defrost water does not run into the kitchen unit.
- If necessary, pick up defrost water several times, using a sponge or cloth.
- Clean the compartment (see 6.2).

6.2 Cleaning the appliance



WARNING

Risk of injury and damage as a result of hot steam!
Hot steam can lead to burns and can damage the surfaces.

- ▶ Do not use any steam cleaners!

NOTICE

Incorrect cleaning damages the appliance!

- ▶ Do not use cleaning agents in concentrated form.
- ▶ Do not use any scouring or abrasive sponges or steel wool.
- ▶ Do not use any sharp or abrasive cleaning agents, nor any that contain sand, chloride or acid.
- ▶ Do not use chemical solvents.
- ▶ Do not damage or remove the type plate on the inside of the appliance. It is important for the customer service.
- ▶ Do not pull off, bend or damage cables or other components.
- ▶ Do not allow any cleaning water to enter the drain channel, ventilation grille or electrical parts.
- ▶ Please use soft cleaning cloths and a universal pH-neutral cleaning agent.
- ▶ Please use cleaning and care products suitable for contact with foodstuffs in the appliance interior.

- ▶ **Empty appliance.**
- ▶ **Pull out the power plug.**



- ▶ Clean **plastic outer and inner surfaces** with lukewarm water and a little washing-up liquid.

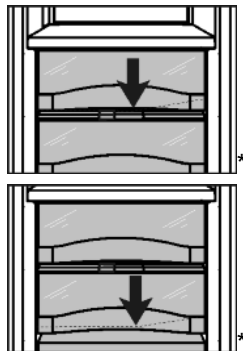

- ▶ Clean **drain hole**: Remove deposits with a narrow instrument, e.g. a cotton bud.

- ▶ Most of the **parts** can be dismantled for cleaning: see the relevant chapter.
- ▶ **Clean drawers** by hand with lukewarm water and a little washing up liquid.
- ▶ Clean the **Fruit & Vegetable safe cover** by hand using lukewarm water and a small amount of detergent.
- ▶ All the **other fittings** can be put in the dishwasher.
- ▶ Only use a damp cloth to clean the **telescopic rails**. The grease in the runners is for lubrication purposes and must not be removed.

After cleaning:

- ▶ Wipe dry the appliance and items of equipment.
- ▶ Connect the appliance and switch it on again.
When the temperature is sufficiently cold:
- ▶ Put the food back inside.

6.3 Customer service

First check whether you can correct the fault yourself by reference to the list (see 7) . If this is not the case, please contact the customer service whose address is given in the enclosed customer service list.



WARNING

Risk of injury if repair work is not carried out professionally!

- ▶ Have any repairs and action - not expressly specified - on the appliance and mains cable carried out by service personnel only. (see 6)

- ▶ Read the appliance designation

Fig. 20 (1), service No. *Fig. 20 (2)* and serial No. *Fig. 20 (3)* off the type plate located inside the appliance on the left-hand side.

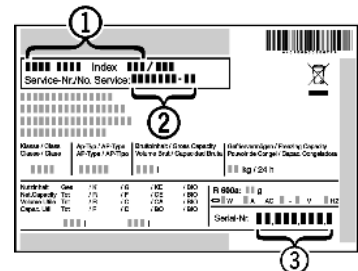

Fig. 20

- ▶ Notify the customer service, specifying the fault, appliance designation *Fig. 20 (1)*, service No. *Fig. 20 (2)* and serial No. *Fig. 20 (3)*.
- ▶ This will help us to provide you with a faster and more accurate service.
- ▶ Keep the appliance closed until the customer service arrives.
- ▶ The food will stay cool longer.
- ▶ Pull out the mains plug (not by pulling the connecting cable) or switch off the fuse.

7 Malfunctions

Your appliance is designed and manufactured for a long life span and reliable operation. If a malfunction nonetheless occurs during operation, check whether it is due to a handling error. In this case you will have to be charged for the costs incurred, even during the warranty period. You may be able to rectify the following faults yourself:

Appliance does not work.

- The appliance is not switched on.
- ▶ Switch on the appliance.
- The power plug is not properly inserted in the wall socket.
- ▶ Check power plug.
- The fuse of the wall socket is not in order.
- ▶ Check fuse.

The compressor runs for a long time.

- The compressor switches to a low speed when little cold is needed. Although the running time is increased as a result, energy is saved.
- ▶ This is normal in energy-saving models.
- SuperCool is activated.
- ▶ The compressor runs for longer in order to rapidly cool the food. This is normal.

A LED on the bottom rear of the appliance (at the compressor) flashes repeatedly every 5 seconds*.

- There is a fault.
- ▶ Please contact the after-sales service (see 6) .

Excessive noise.

- Due to the various speed steps, speed-regulated* compressors can generate different running noises.
- ▶ The sound is normal.

A bubbling and gurgling noise.

- This noise comes from the refrigerant flowing in the refrigeration circuit.
- ▶ The sound is normal.

A quiet clicking noise.

- The noise is produced whenever the refrigeration unit (motor) automatically switches on or off.

Decommissioning

- ▶ The sound is normal.

A hum. It is briefly a little louder when the refrigeration unit (the motor) switches on.

- The refrigeration increases automatically when the SuperCool function is activated, fresh food has just been placed in the appliance or the door has been left open for a while.
- ▶ The sound is normal.
- The ambient temperature is too high.
- ▶ Solution: (see 1.2)

A low hum.

- The sound is produced by air flow noise of the fan.
- ▶ The sound is normal.

Vibration noises

- The appliance is not standing firmly on the floor. As a result objects and adjacent units start to vibrate when the refrigerator is running.
- ▶ Check the installation and realign the appliance.
- ▶ Keep bottles and jars apart.

Flow sound at the soft stop mechanism.

- The noise is produced when the door is opened and closed.
- ▶ The sound is normal.

The temperature display indicates: F0 to F9

- There is a fault.
- ▶ Please contact the after-sales service (see 6).

DEMO shines in the temperature display.

- The demo mode is activated.
- ▶ Please contact the after-sales service (see 6).

The outer surfaces of the appliance are warm*.

- The heat of the refrigeration circuit is used to prevent condensate from forming.
- ▶ This is normal.

The temperature is not cold enough.

- The door of the appliance is not properly closed.
- ▶ Close the door of the appliance.
- Insufficient ventilation.
- ▶ Keep ventilation grille clear, and clean it.
- The ambient temperature is too high.
- ▶ Solution: (see 1.2).
- The appliance was opened too frequently or for too long.
- ▶ Wait to see whether the appliance reaches the required temperature by itself. If not, please contact the after sales service (see 6).
- The temperature is incorrectly set.
- ▶ Set the temperature to a colder setting and check after 24 hours.
- The appliance is too close to a source of heat (stove, heater etc).
- ▶ Change the position of the appliance or the source of heat.
- The appliance was not inserted properly into the recess.
- ▶ Check whether the appliance was inserted correctly and the door closes properly.

The internal light does not come on.

- The appliance is not switched on.
- ▶ Switch the appliance on.
- The door was open for longer than 15 minutes.
- ▶ The internal light switches itself off automatically after about 15 minutes if the door is open.
- The LED illumination is faulty or the cover is damaged:



WARNING

Risk of injury due to electric shock!

Live parts are located under the cover.

- ▶ Have the LED interior light changed or repaired only by the customer service or by specialized personnel trained for the purpose.



WARNING

Danger of injury by LED lamp!

The light intensity of the LED lighting corresponds to risk group RG 2.

If the cover is defective:

- ▶ Do not look into the illumination with optical lenses from the immediate proximity. This can cause injury to the eyes.

The door gasket is defective or should be replaced for other reasons.*

- In some units, the seal around the door can be replaced. You will not need any special tools to do this.
- ▶ Please contact the after-sales service (see 6).

The unit has iced up or condensation has formed.*

- The door seal may have also slipped out of its groove.
- ▶ Check to ensure that the door seal is seated properly in the groove.

8 Decommissioning

8.1 Switching off the appliance

- ▶ Press On/Off button *Fig. 2 (1)* for approx. 2 seconds.
- ▷ A long beep is emitted. The temperature display is dark. The appliance is switched off.
- ▷ If the appliance cannot be switched off, the child lock function is active (see 5.1).

8.2 Taking the appliance out of service

- ▶ Empty the appliance.
- ▶ Switch off the appliance (see 8).
- ▶ Remove mains connector.
- ▶ Clean the appliance (see 6.2).

- ▶ Leave the door open to prevent odour.



9 Disposing of the appliance

The appliance contains some reusable materials and should be disposed of properly - not simply with unsorted household refuse. Appliances which are no longer needed must be disposed of in a professional and appropriate way, in accordance with the current local regulations and laws.



When disposing of the appliance, ensure that the refrigeration circuit is not damaged to prevent uncontrolled escape of the refrigerant it contains (data on type plate) and oil.

- ▶ Disable the appliance.
- ▶ Pull out the plug.
- ▶ Cut through the connecting cable.



Liebherr-Hausgeräte Ochsenhausen GmbH

Memminger Straße 77-79

88416 Ochsenhausen

Deutschland

home.liebherr.com